



Surname _____

Other Names _____

Centre Number _____

Candidate Number _____

Candidate Signature _____

AS

PHYSICS

Paper 2

7407/2

Friday 18 May 2018 Morning

Time allowed: 1 hour 30 minutes

At the top of the page, write your surname and other names, your centre number, your candidate number and add your signature.

[Turn over]



For this paper you must have:

- **a pencil and a ruler**
- **a scientific calculator**
- **a Data and Formulae booklet.**

INSTRUCTIONS

- **Use black ink or black ball-point pen.**
- **Answer ALL questions.**
- **You must answer the questions in the spaces provided. Do not write on blank pages.**
- **Do all rough work in this book. Cross through any work you do not want to be marked.**
- **Show all your working.**



INFORMATION

- **The marks for questions are shown in brackets.**
- **The maximum mark for this paper is 70.**
- **You are expected to use a scientific calculator where appropriate.**
- **A Data and Formulae Booklet is provided as a loose insert.**

DO NOT TURN OVER UNTIL TOLD TO DO SO



SECTION A

Answer ALL questions in this section.

0 1 FIGURE 1 shows the apparatus used by a student in an experiment to measure the acceleration due to gravity, g .

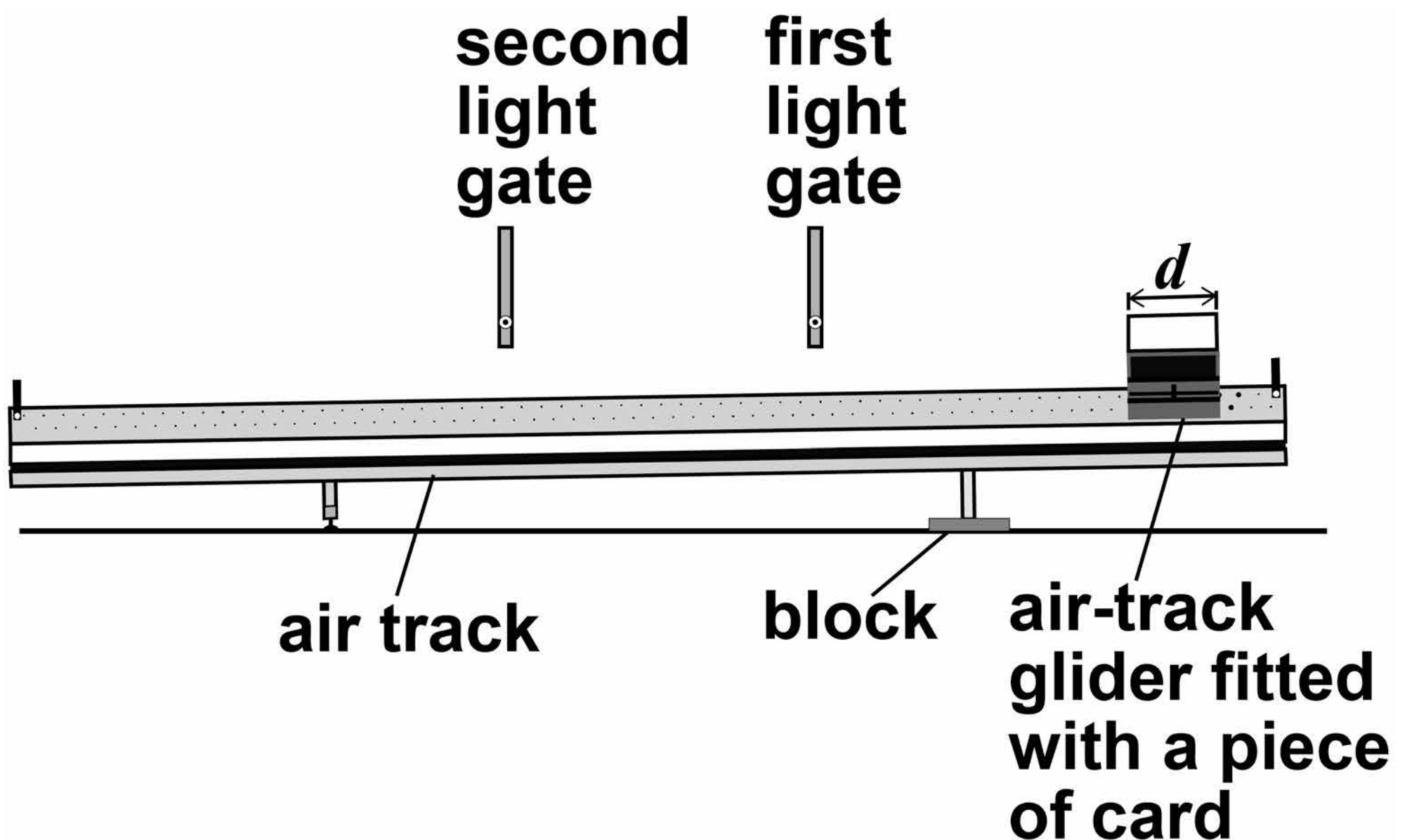
FIGURE 1

5

In the experiment:

- **a block is used to raise one end of the air track as shown in FIGURE 1**
- **an air-track glider is released from rest near the raised end of the air track and passes through the first light gate and then through the second light gate**
- **a piece of card of length d fitted to the air-track glider interrupts a light beam as the air-track glider passes through each light gate**
- **a data logger records the time taken by the piece of card to pass through each light gate and also the time for the piece of card to travel from one light gate to the other.**

[Turn over]



6

01.1 TABLE 1 gives measurements made with the light gates as shown in FIGURE 1.

TABLE 1

Time to pass through first light gate / s	Time to pass through second light gate / s	Time to travel from first to second light gate / s
0.50	0.40	1.19

The length d of the piece of card is 10.0 cm

Assume there is negligible change in velocity while the air-track glider passes through a light gate.



7

Determine the acceleration a of the air-track glider. [3 marks]

$a =$ _____ m s^{-2}

[Turn over]



01.2 Two further sets of readings, A and B, are taken each with the light gates in different positions along the air track.

Assume the acceleration is the same in each set.

TABLE 2 shows these additional sets of results.

TABLE 2

Set	Time to pass through first light gate / s	Time to pass through second light gate / s	Time to travel from first to second light gate / s
A	0.61	0.42	1.77
B	0.55	0.37	2.11

9

Explain how the data in TABLE 2 show that the distance between the light gates in set B is greater than in set A.

**Assume there is negligible change in velocity while the air-track glider passes through a light gate.
[2 marks]**

Continue your answer on page 11.

[Turn over]



BLANK PAGE



01.3 Additional values for the acceleration of the air-track glider are obtained by further raising the end of the air track by using a stack consisting of identical blocks. Adding each block to the stack raises the end of the air track by the same distance.

[Turn over]



12

FIGURE 2 is a graph of these results showing how a varies with n , the number of blocks in the stack.

Draw a suitable best-fit straight line on FIGURE 2 and determine G , the gradient of your line. [2 marks]

$G =$ _____



FIGURE 2

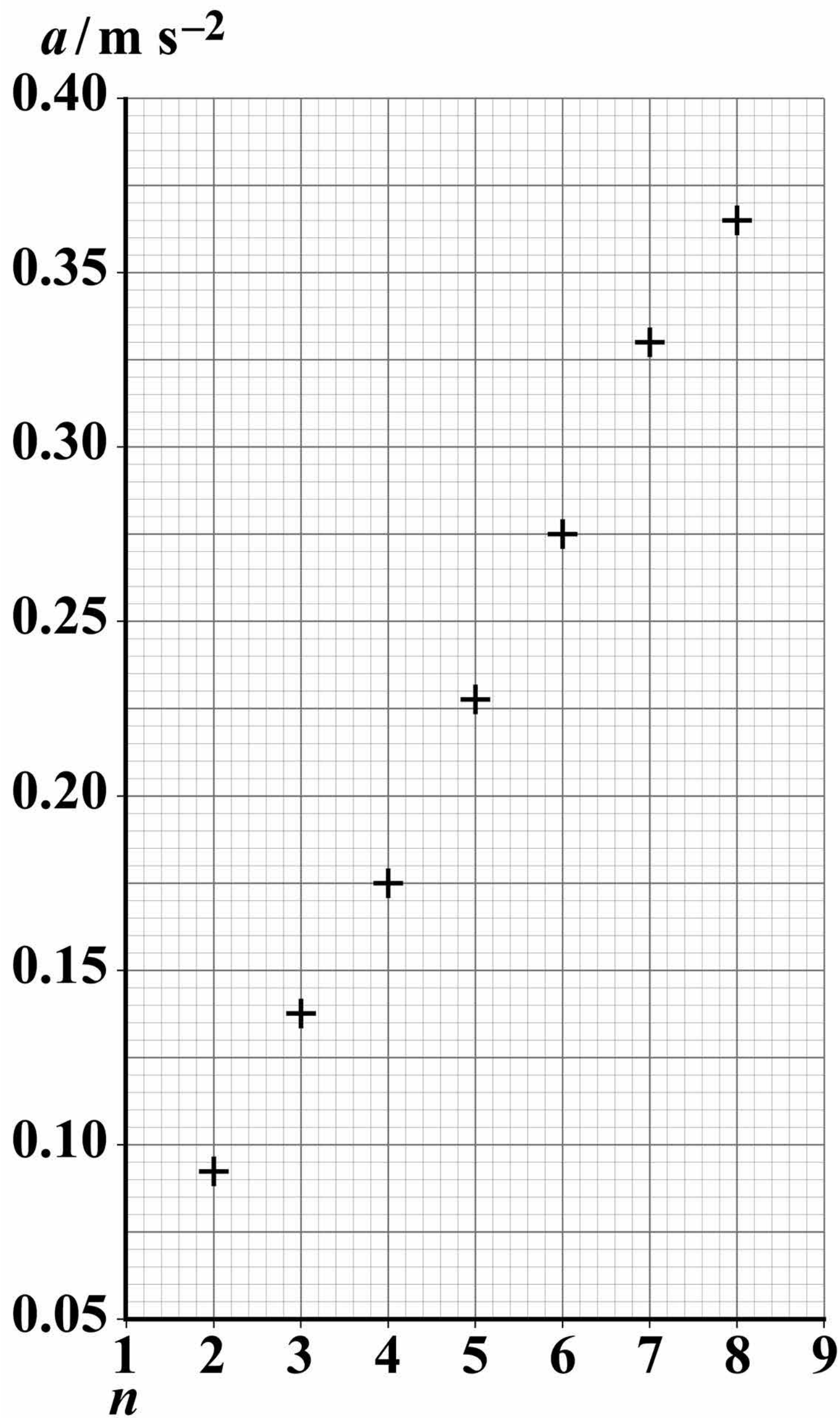

[Turn over]



14

0 1 . 4 It can be shown that, for the apparatus used by the student, g is equal to $\frac{2G}{h}$ where h is the thickness of each block used in the experiment.

The student obtains a value for g of 9.8 m s^{-2}

Calculate h . [1 mark]

$h =$ _____ **m**



15

0 1 . 5 Explain how you could find out, without drawing another graph, whether the data presented in the graph in **FIGURE 2**, on page 13, support the suggestion that a is directly proportional to n . [1 mark]

[Turn over]

9



16

0	2
---	---

Identical ring magnets A and B are arranged on a cylindrical wooden rod.

The magnets' magnetic poles are on their largest faces. When placed with like poles in opposition, the magnets repel one another as shown in **FIGURE 3.**

The plan and sectional views in **FIGURE 3 identify the dimensions of these magnets. Each magnet has a circular cross-section and the central hole is circular.**



The diagram is not drawn to scale.

FIGURE 3

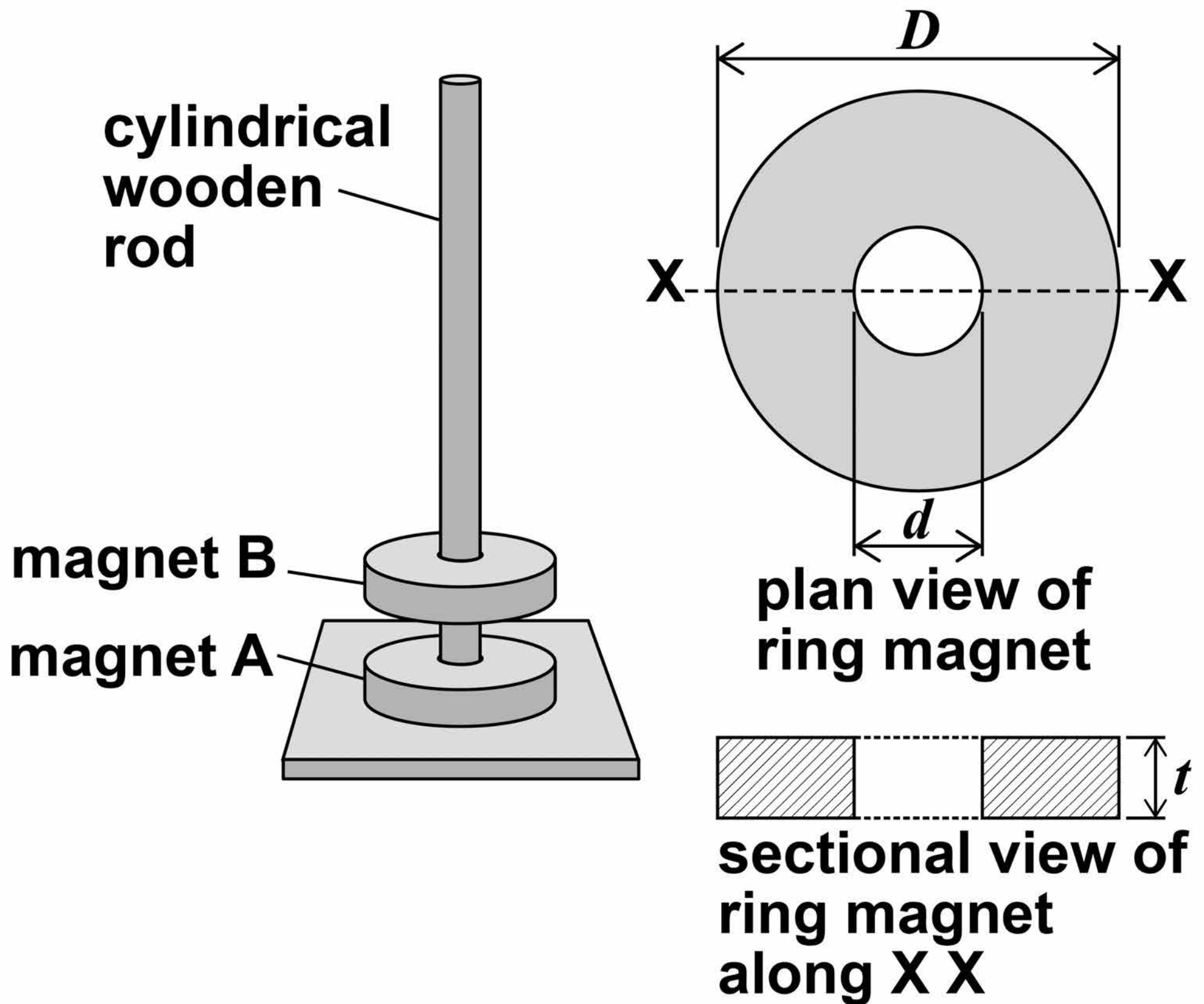

[Turn over]



0 2 . 1 A student uses digital vernier calipers to find the external diameter D of magnet B, as shown in FIGURE 4.

FIGURE 4

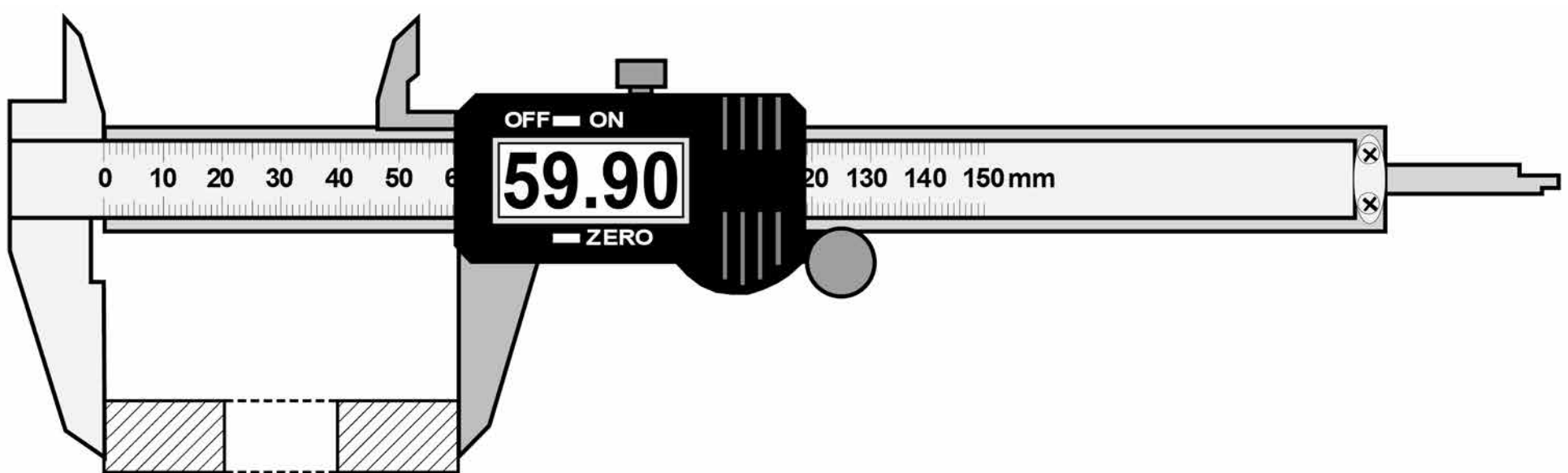

State precautions the student should take to reduce the effect of systematic and random errors when making this measurement. [2 marks]

19

Precaution to reduce effect of systematic error:

Precaution to reduce effect of random error:

[Turn over]



20

02.2 FIGURE 5 shows the reading on the calipers as the internal diameter d is measured.

Draw the sectional view of magnet B on FIGURE 5 to indicate how d is measured.
[1 mark]

FIGURE 5

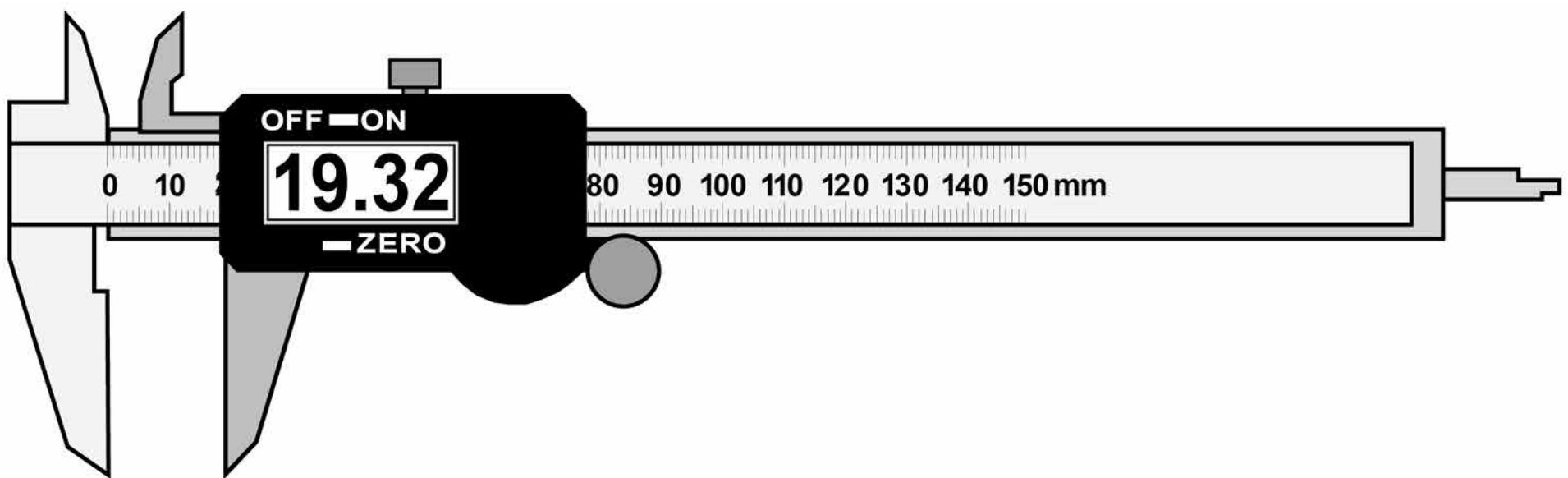

BLANK PAGE

[Turn over]



02.3 FIGURE 6 shows the reading on the calipers when the thickness t of magnet B is measured.

FIGURE 6

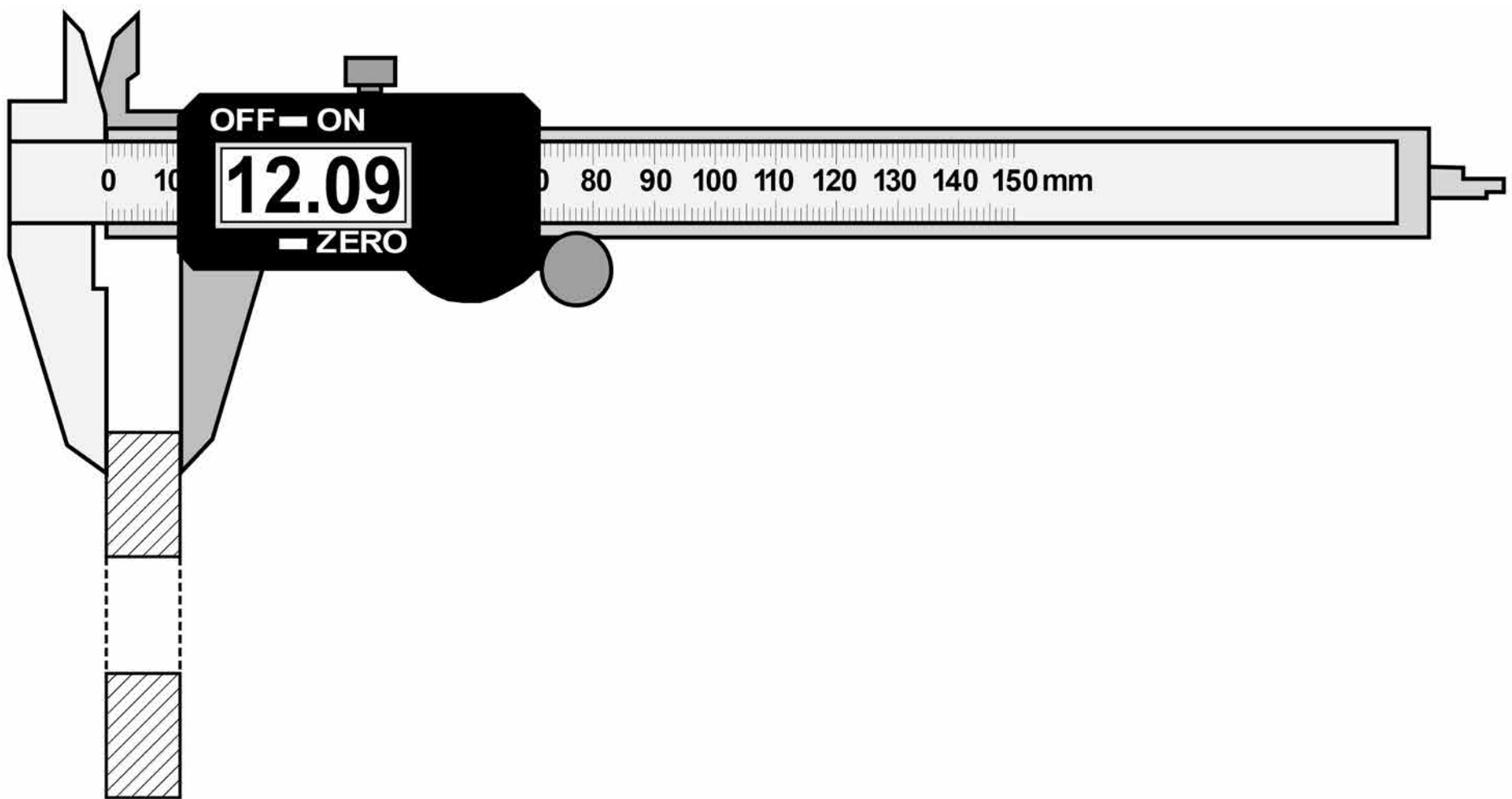

23

The readings that correspond to the dimensions of magnet B are shown in FIGURES 4, 5 and 6.

Calculate the volume of magnet B.
[3 marks]

volume = _____ m³

[Turn over]



0 2 . 4 The student measures the mass m_B of magnet B and then positions the magnet so it is in equilibrium above magnet A as shown in FIGURE 7.

The student measures the distance h .

FIGURE 7

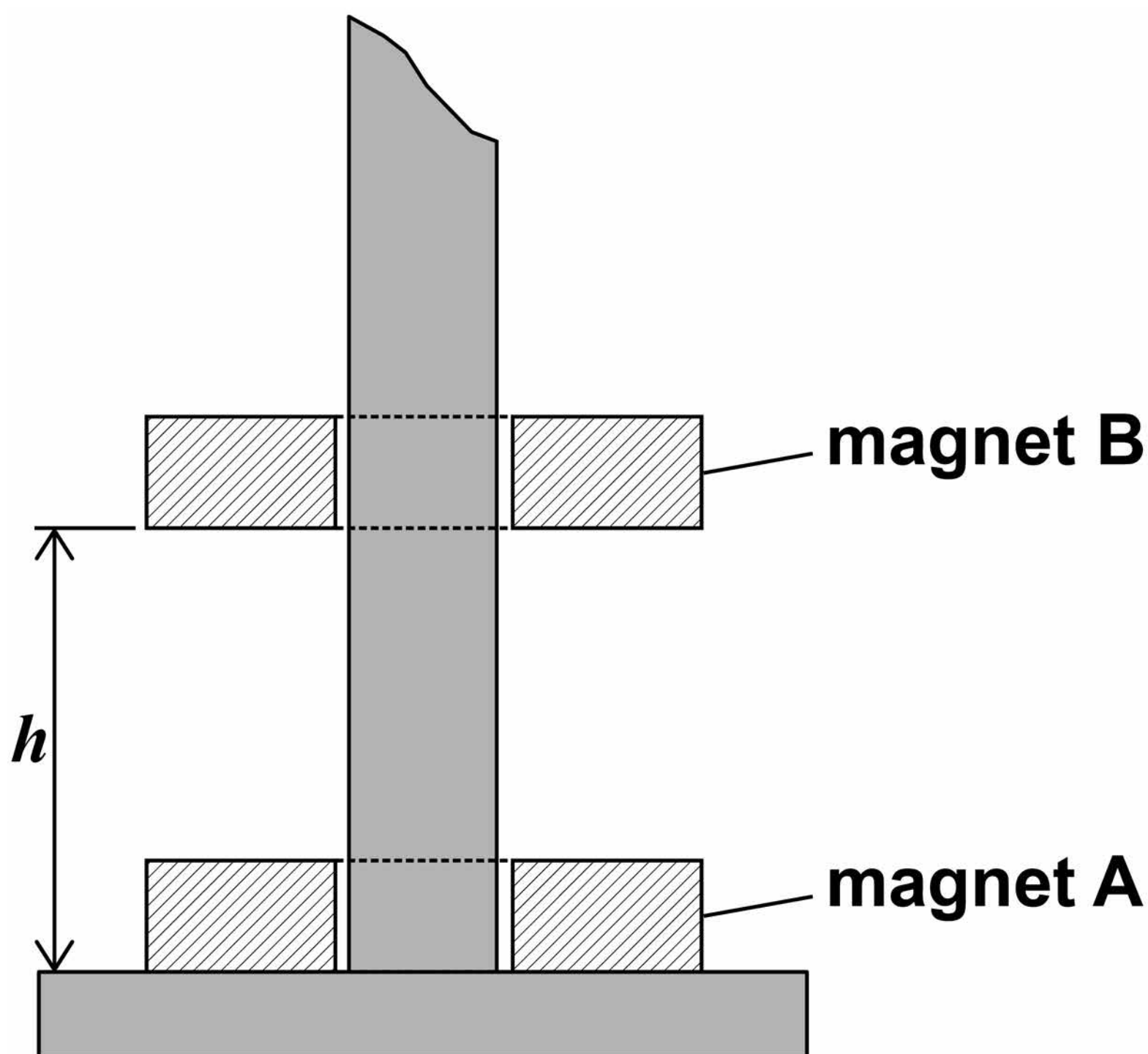

25

The student adds modelling clay to magnet B to reduce h by 50%
She measures the mass m_C of this clay.

She concludes that the force F exerted on magnet B by magnet A is given by

$$F = \frac{k}{h^3} \text{ where } k \text{ is a constant.}$$

Describe an experiment to test the student's conclusion that

$$F = \frac{k}{h^3}$$

Your answer should include:

- the procedure that could be used
- how the data produced could be analysed by a graphical method
- how the value of the constant k could be determined.

[5 marks]

[Turn over]



SECTION B

Answer ALL questions in this section.

0 3

A radioactive source emits alpha particles each with 8.1×10^{-13} J of kinetic energy.

0 3 . 1

Show that the velocity of an alpha particle with kinetic energy 8.1×10^{-13} J is approximately 2×10^7 m s⁻¹

specific charge of an alpha particle = 4.81×10^7 C kg⁻¹

[2 marks]



29

03.2 The alpha particles travel through air in straight lines with a range of 3.5 cm

**Calculate the average force exerted on an alpha particle as it is stopped by the air.
[2 marks]**

average force = _____ N

[Turn over]



BLANK PAGE



31

03.3 An alpha particle transfers all its kinetic energy to air molecules and produces 5.1×10^4 ions per centimetre over its range of 3.5 cm

Calculate the average ionisation energy, in eV, of a molecule of air. [3 marks]

ionisation energy =

eV

[Turn over]



- 03.4** A spark counter consists of a wire gauze separated from a metal wire by a small air gap. A power supply with an output of 4500 V is connected in series with a 5.0 M Ω resistor and the spark counter as shown in FIGURE 8. When the radioactive source is moved close to the wire gauze, sparking is seen in the air gap.

FIGURE 8

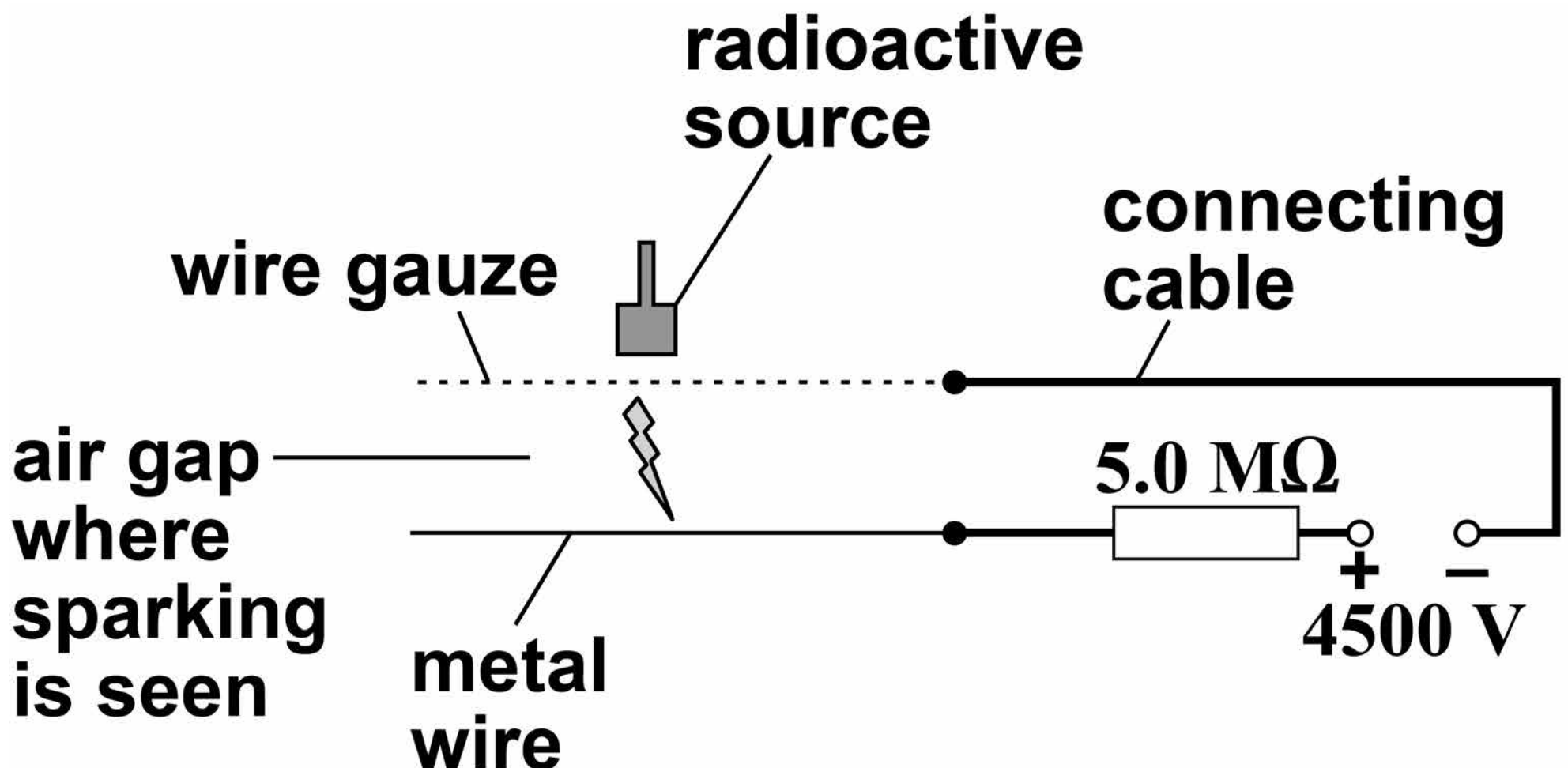

33

Sparks are produced when alpha particles produce ionisation in the air gap.

One ionisation event produces a current of 0.85 mA for a time of 1.2 ns

Calculate the number of charge carriers that pass a point in the connecting cable during this ionisation event. [2 marks]

number of charge carriers =

[Turn over]



34

03.5 The radioactive source was positioned 10 cm above the wire gauze before being moved slowly towards the wire gauze leading to the ionisation event in question 03.4.

Discuss how the potential difference across the air gap varied as the radioactive source was moved over this distance.

**Assume the power supply has negligible internal resistance.
[3 marks]**



04.1 FIGURE 9 shows an incident ray of light being partially reflected at the boundary between glass A and glass B. The refractive index n_A of glass A is 1.461

The speed of light in glass B is 3.252% less than the speed of light in glass A.

FIGURE 9

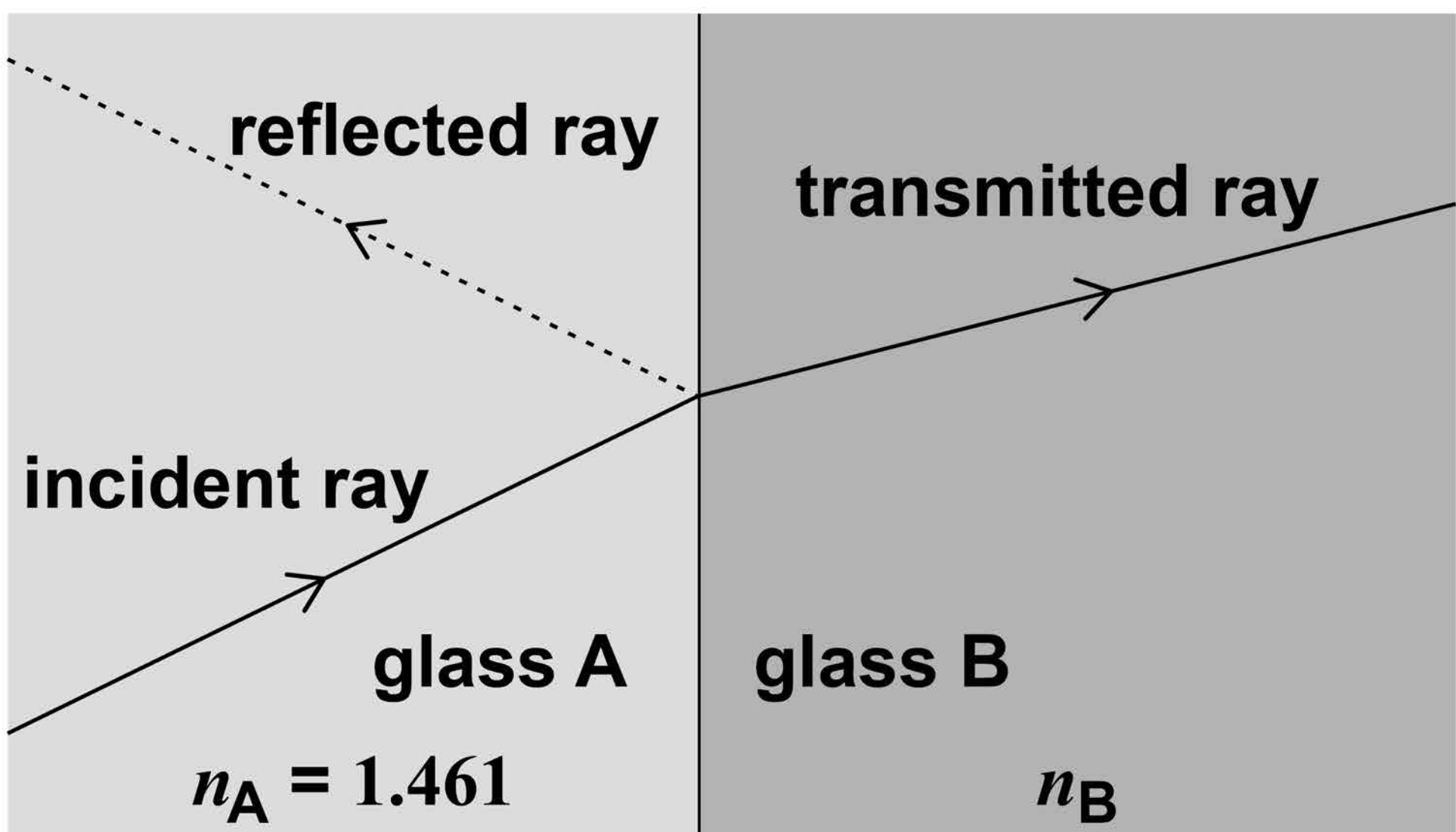

37

Calculate the refractive index n_B of glass B.

Give your answer to an appropriate number of significant figures.

**speed of light in a vacuum =
 $2.998 \times 10^8 \text{ m s}^{-1}$ [3 marks]**

$n_B =$ _____

[Turn over]



04.2 FIGURE 10 shows a cross-sectional view of an optical fibre strain gauge.

FIGURE 10

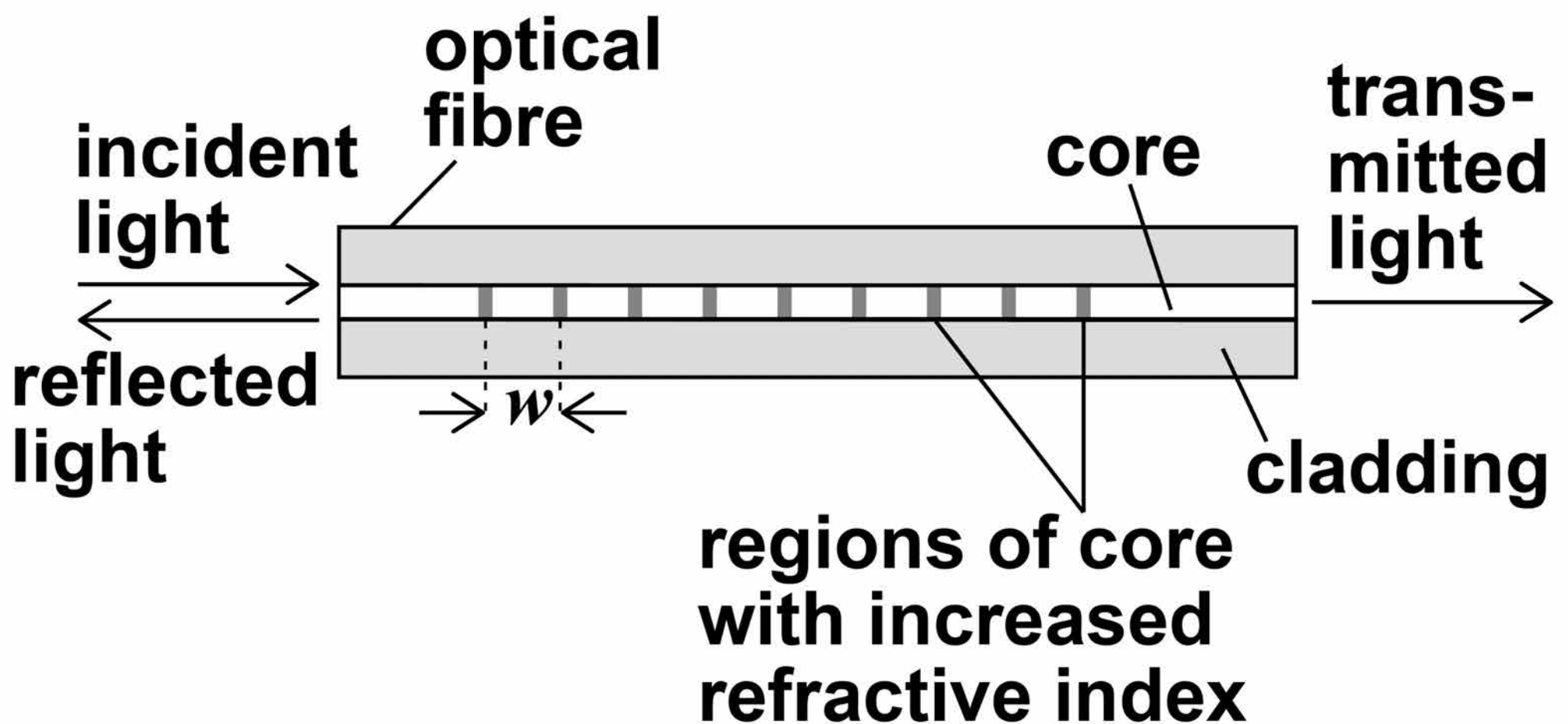

A maximum intensity of the reflected light is produced due to superposition of the light reflected from each of the regions with increased refractive index in the core.

This maximum intensity occurs at a particular wavelength λ_R .



FIGURE 11 shows the relationship between λ_R and the strain in the optical fibre.

FIGURE 11

λ_R / m

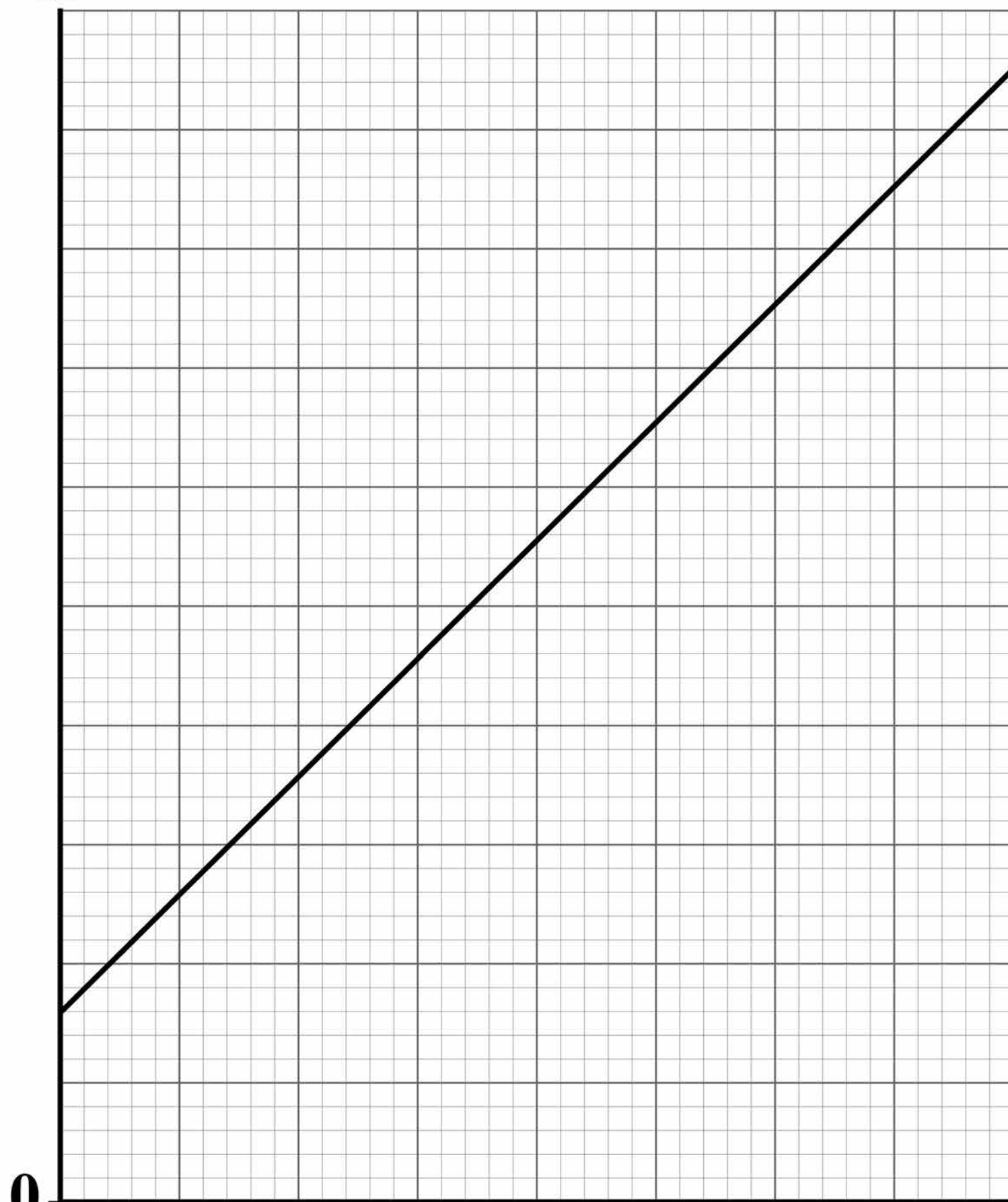

0
0
strain in optical fibre

[Turn over]



40

A cable is used to raise and lower a lift. An engineer fixes the optical fibre strain gauge to the cable to monitor changes of the strain in the cable.

The lift is initially at rest and then accelerates downwards for a short time before reaching a constant velocity.

Discuss how the value of λ_R changes. [3 marks]



[Turn over]



04.3 FIGURE 12 shows the relationship between λ_R and the strain in two optical fibre strain gauges P and Q. The engineer wishes to measure small accelerations in another lift. She can choose to fix either optical fibre strain gauge P or optical fibre strain gauge Q to the lift's cable.



FIGURE 12

λ_R / m

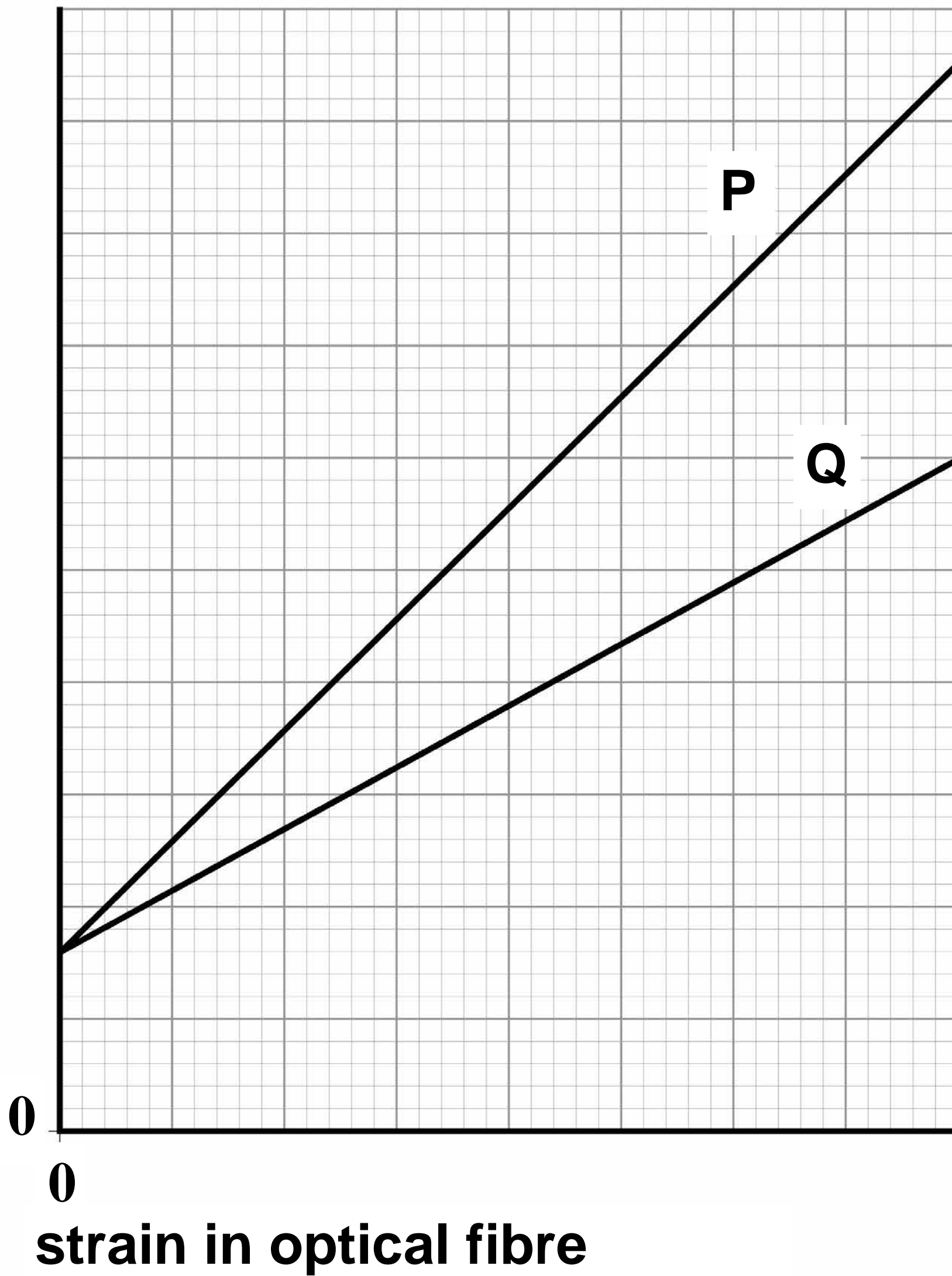

[Turn over]



BLANK PAGE



SECTION C

Each of Questions 05 to 34 is followed by four responses, A, B, C and D.

For each question select the best response.

Only ONE answer per question is allowed.

For each answer completely fill in the circle alongside the appropriate answer.

CORRECT METHOD

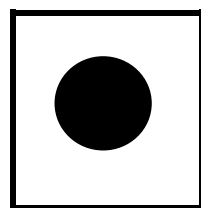

WRONG METHODS

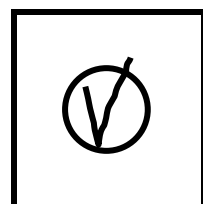
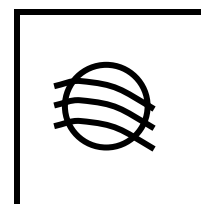
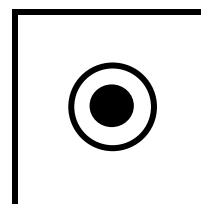
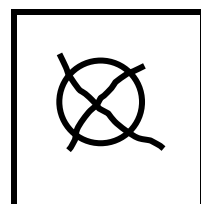

If you want to change your answer you must cross out your original answer as shown.

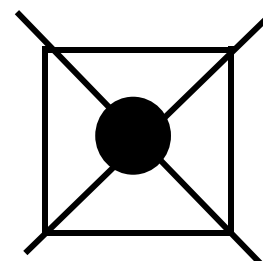

If you wish to return to an answer previously crossed out, ring the answer you now wish to select as shown.

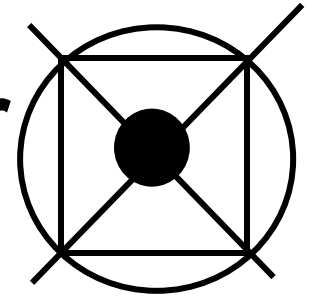

You may do your working in the blank space around each question but this will not be marked.

Do NOT use additional sheets for this working.

[Turn over]



48

05

The graph of neutron number against proton number shows three nuclei P, Q and R.

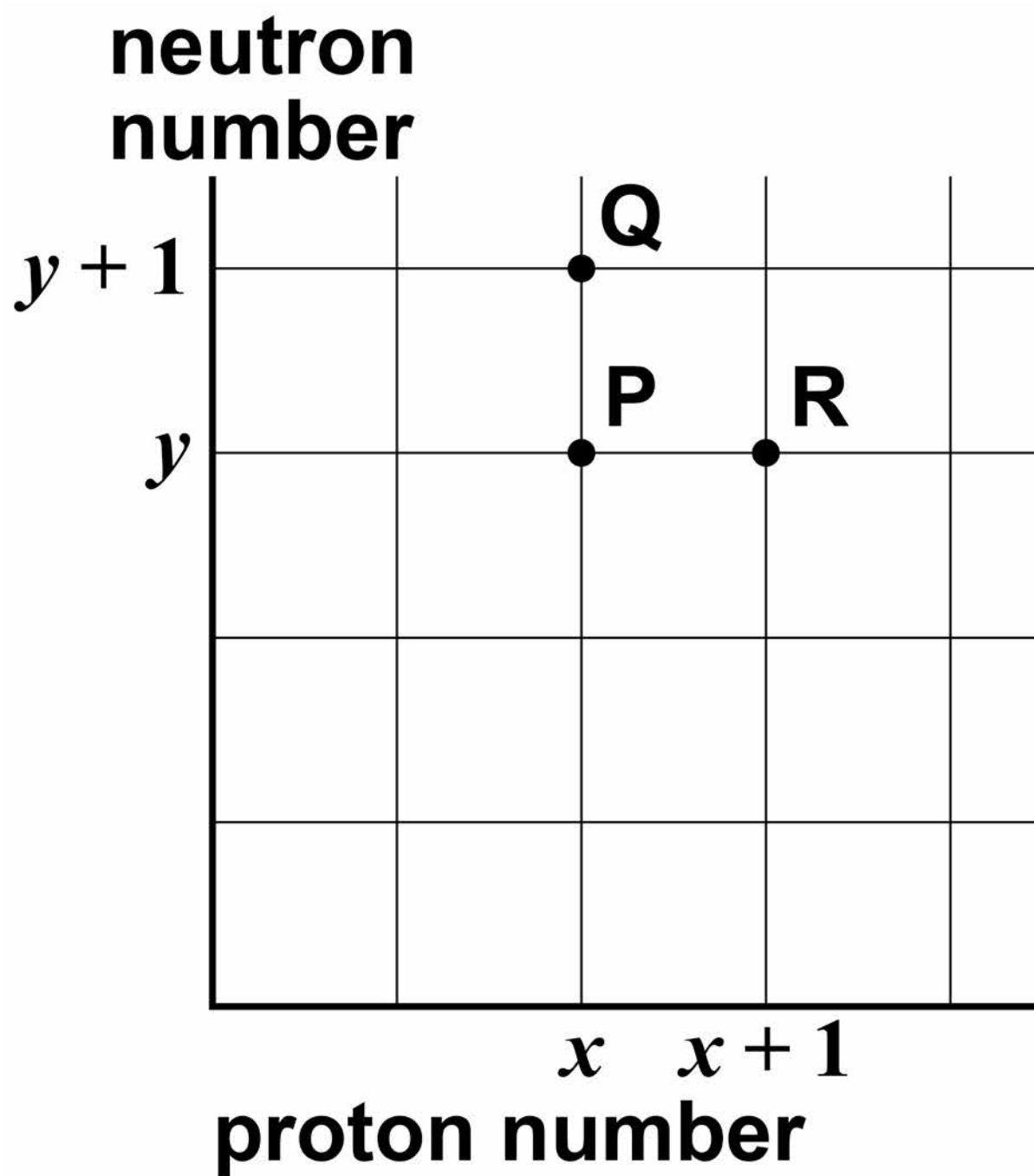

Which row identifies an isotope of P and the nucleon number of this isotope of P? [1 mark]

		Isotope of P	Nucleon number of isotope of P
<input type="checkbox"/>	A	Q	$y + 1$
<input type="checkbox"/>	B	Q	$x + y + 1$
<input type="checkbox"/>	C	R	$x + y + 1$
<input type="checkbox"/>	D	R	$x + 1$

[Turn over]



50

0	6
---	---

${}_{92}^{236}\text{U}$ undergoes a series of decays to produce ${}_{82}^{204}\text{Pb}$.

How many alpha decays are involved in this decay series?
[1 mark]

A 5**B 6****C 8****D 10**

BLANK PAGE

[Turn over]



07

The partially completed diagram represents electron capture.

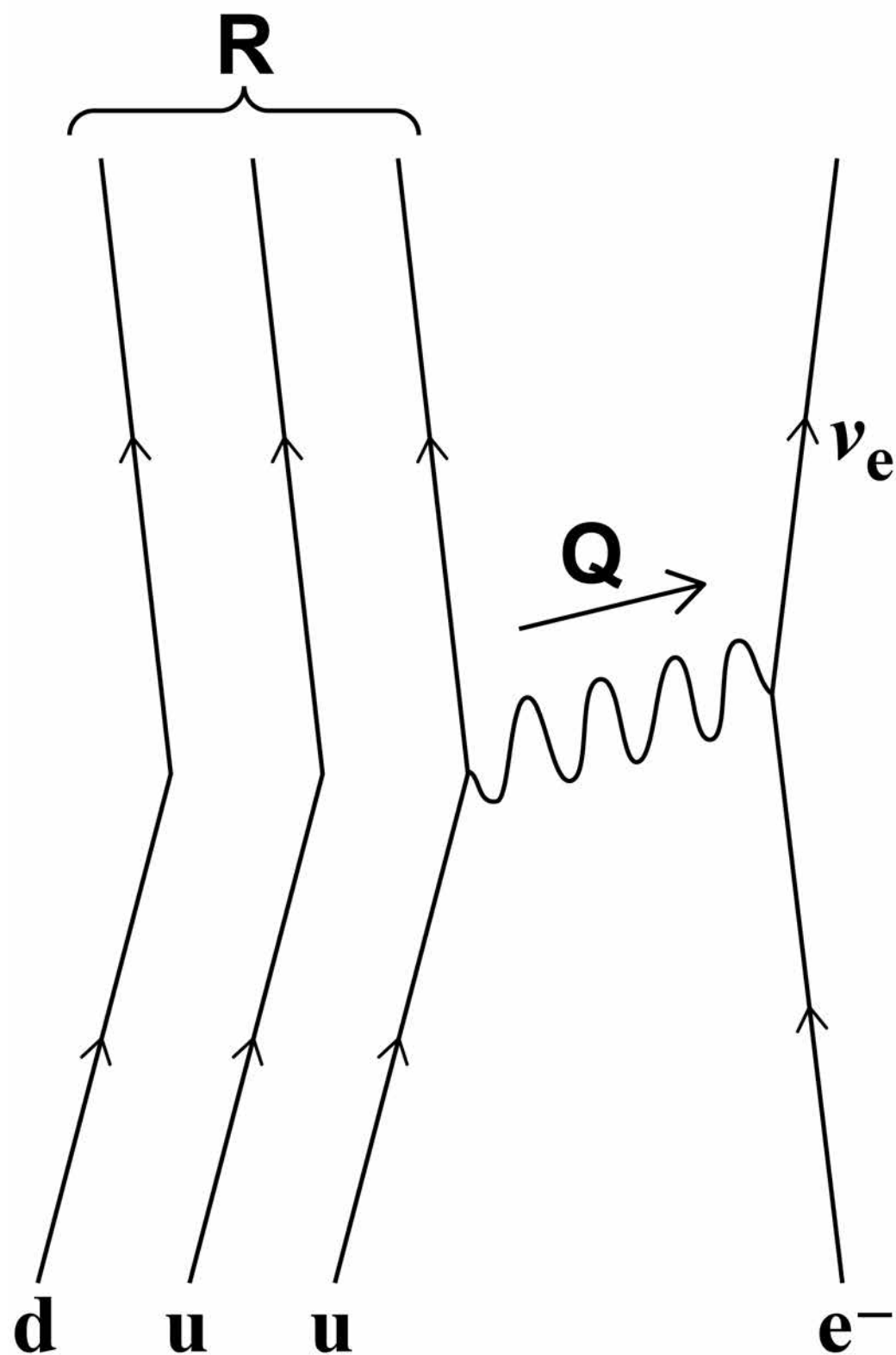

53

Which row identifies the exchange particle Q and the quark structure of particle R? [1 mark]

		Particle Q	Quark structure of particle R
<input type="checkbox"/>	A	W^{-}	uuu
<input type="checkbox"/>	B	W^{+}	dud
<input type="checkbox"/>	C	W^{+}	uuu
<input type="checkbox"/>	D	W^{-}	dud

[Turn over]



0 8 The decay of a neutral kaon K^0 is given by the equation

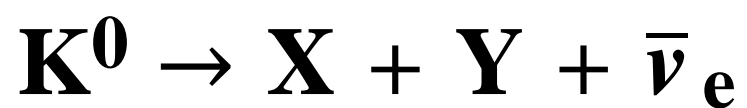

What are X and Y? [1 mark]

		X and Y
<input type="checkbox"/>	A	e^+ and e^-
<input type="checkbox"/>	B	μ^+ and e^-
<input type="checkbox"/>	C	π^+ and e^-
<input type="checkbox"/>	D	π^- and e^+

BLANK PAGE

[Turn over]



- 09** The graph shows how the maximum kinetic energy E_k of photoelectrons emitted from a metal surface varies with the reciprocal of the wavelength λ of the incident radiation.

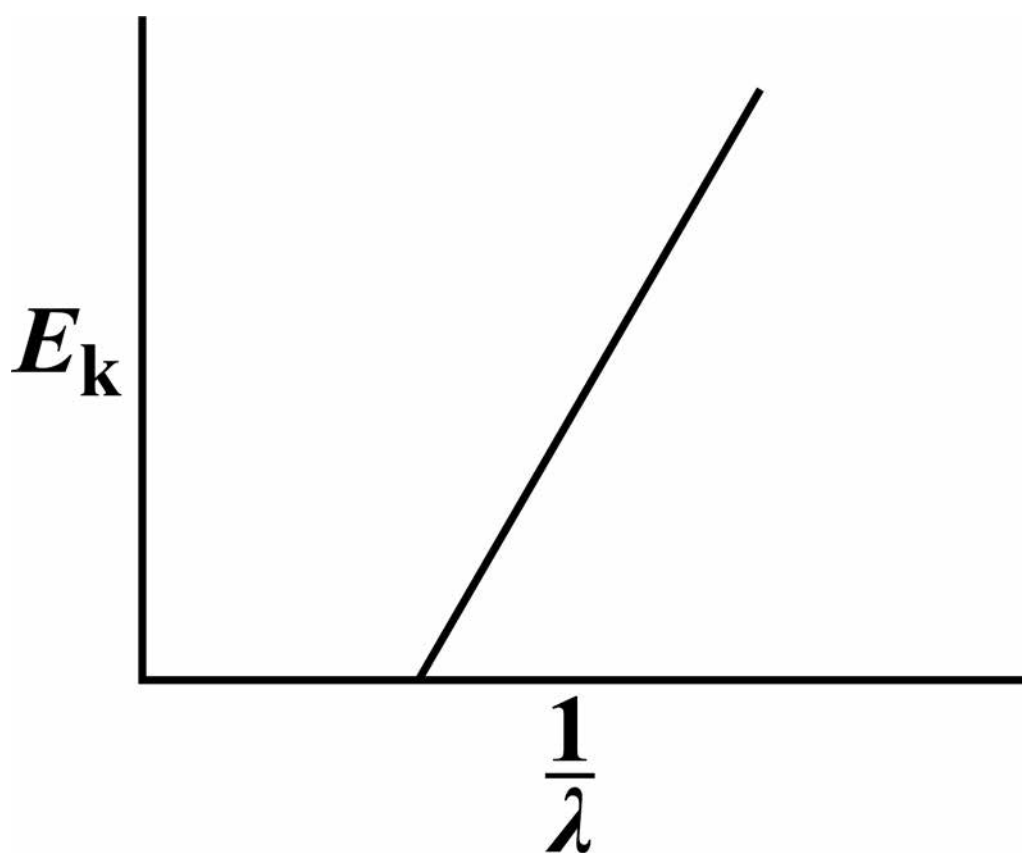

57

What is the gradient of this graph?
[1 mark]

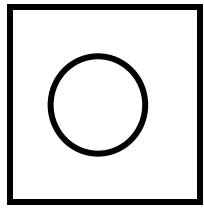
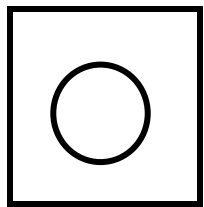
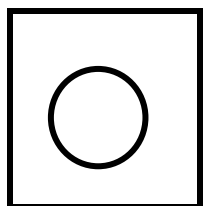
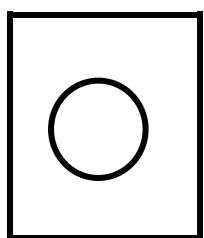
**A** c **B** h **C** hc **D** $\frac{h}{c}$

[Turn over]



- 10** An atom in the inner coating of a fluorescent tube absorbs a photon of ultraviolet radiation. This causes excitation of the atom from its ground state. A photon of visible light is then emitted.

Which energy level diagram represents this process?

[1 mark]

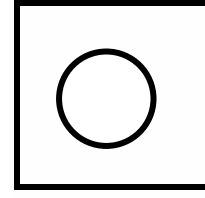

A

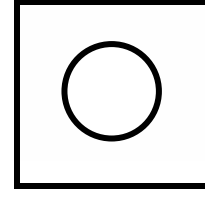
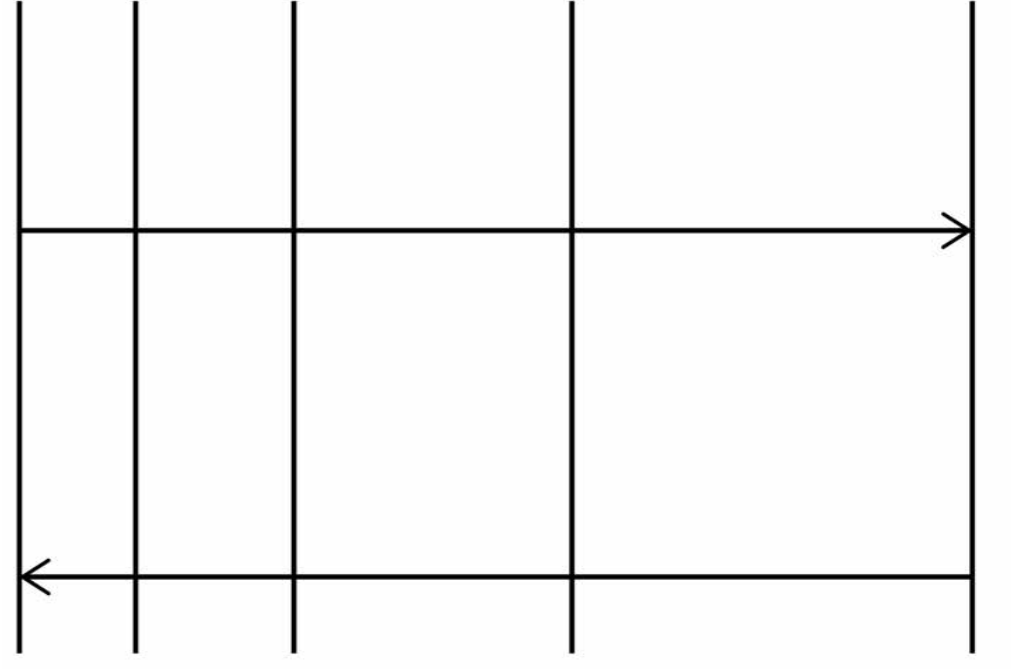

B

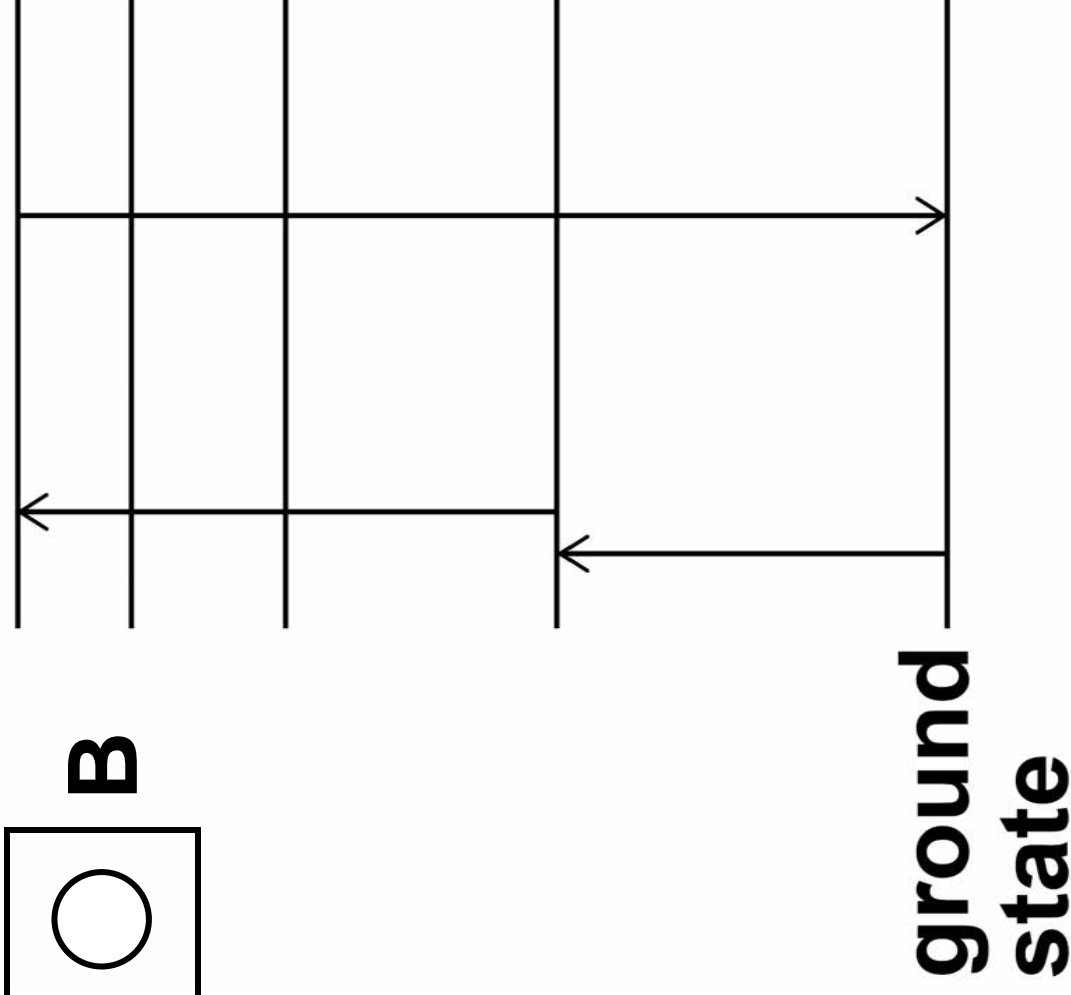

58

ground
state



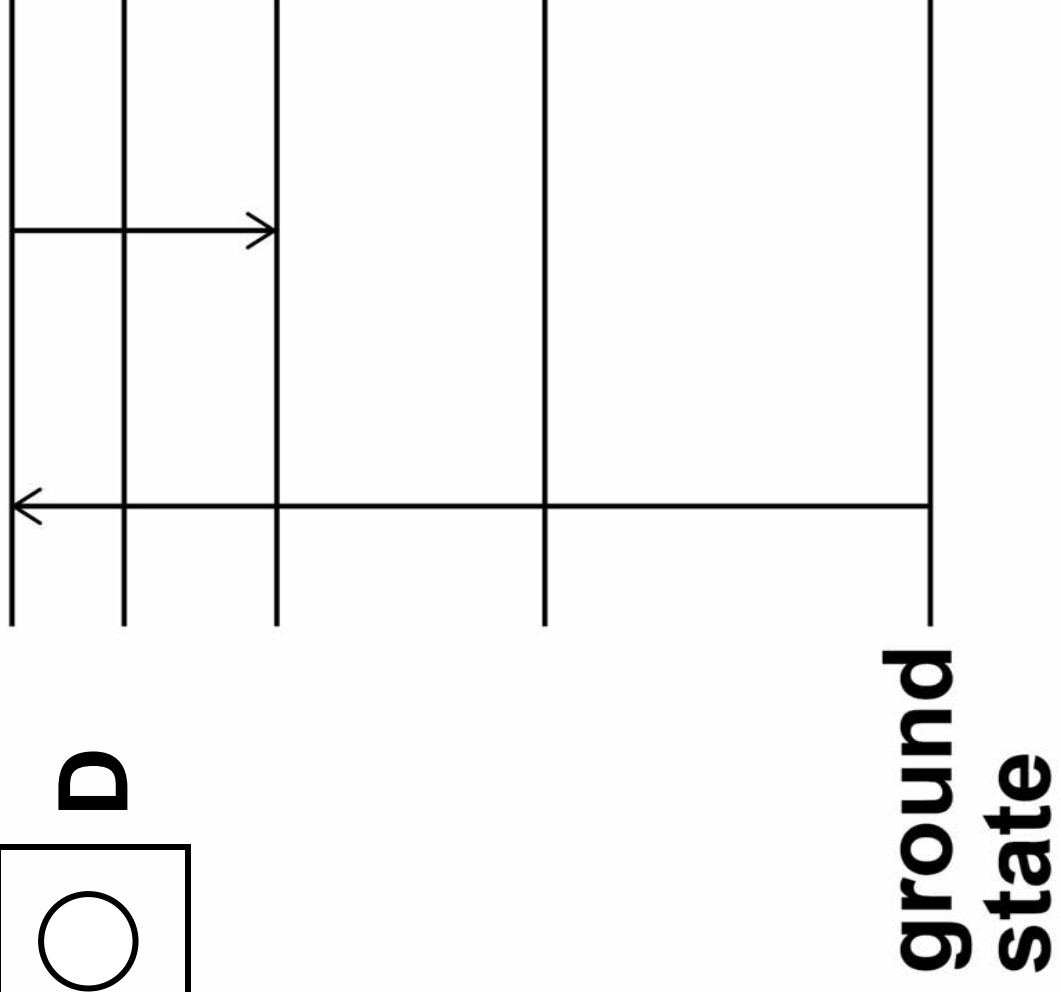
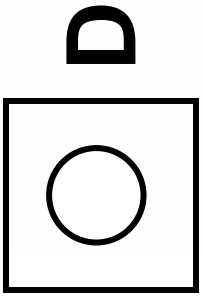
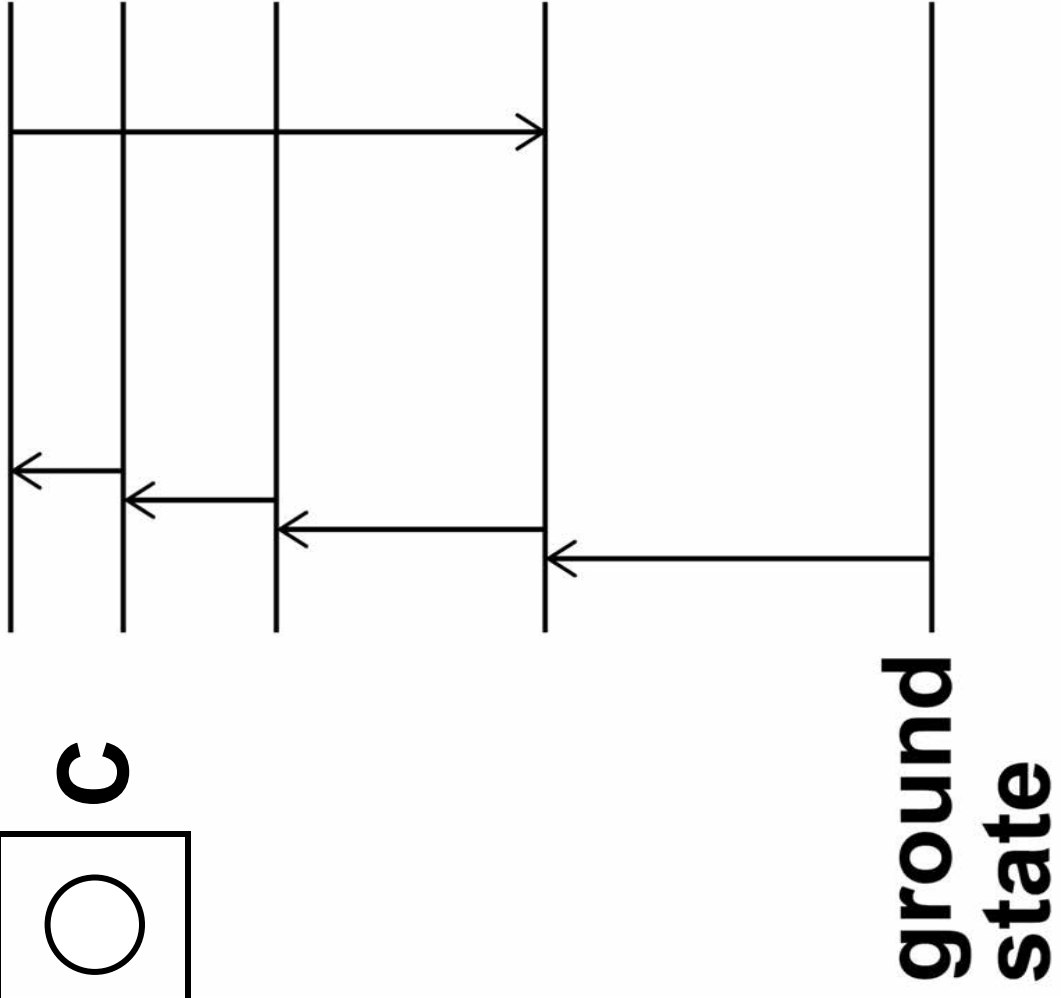
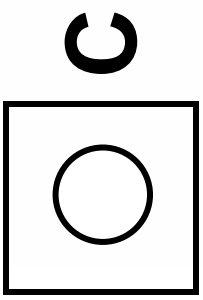

[Turn over]



1	1
---	---

A particle of mass m has a kinetic energy of E .

What is the de Broglie wavelength of this particle? [1 mark]

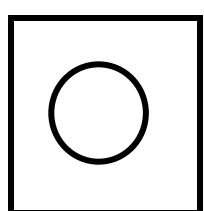

A
$$\frac{h}{\sqrt{(2Em^2)}}$$

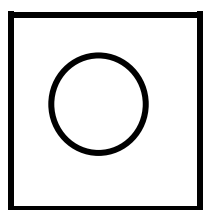

B
$$\frac{h}{\sqrt{2E}}$$

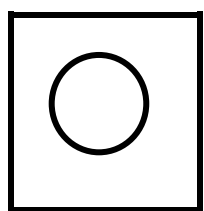

C
$$\frac{h}{\sqrt{\left(\frac{2E}{m^2}\right)}}$$

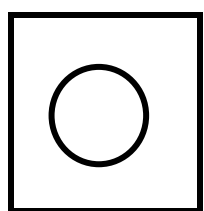

D
$$\frac{h}{\sqrt{2Em}}$$



- 1 2** Which row links both the photoelectric effect and electron diffraction to the properties of waves and particles? [1 mark]

		Photoelectric effect	Electron diffraction
<input type="checkbox"/>	A	Particle property	Particle property
<input type="checkbox"/>	B	Wave property	Wave property
<input type="checkbox"/>	C	Particle property	Wave property
<input type="checkbox"/>	D	Wave property	Particle property

[Turn over]



- 1 3** Measurements are made to determine the tension, length and mass per unit length of a string stretched between two supports. The percentage uncertainties in these measurements are shown below.

Quantity	Percentage uncertainty
Length	0.80%
Tension	4.0%
Mass per unit length	2.0%



63

A stationary wave is formed on the string.

What is the percentage uncertainty in the calculated value of the frequency of the first harmonic? [1 mark]

A 1.8%

B 3.8%

C 6.8%

D 13%

[Turn over]



1	4
---	---

Which list puts the forces in order of increasing magnitude? [1 mark]

A $2 \text{ pN} < 2 \text{ fN} < 2 \text{ TN} < 2 \text{ GN}$

B $2 \text{ pN} < 2 \text{ fN} < 2 \text{ GN} < 2 \text{ TN}$

C $2 \text{ fN} < 2 \text{ pN} < 2 \text{ TN} < 2 \text{ GN}$

D $2 \text{ fN} < 2 \text{ pN} < 2 \text{ GN} < 2 \text{ TN}$



BLANK PAGE

[Turn over]



66

15

A ray of light is incident on a glass–air boundary of a rectangular block as shown.

The diagram is not drawn to scale.

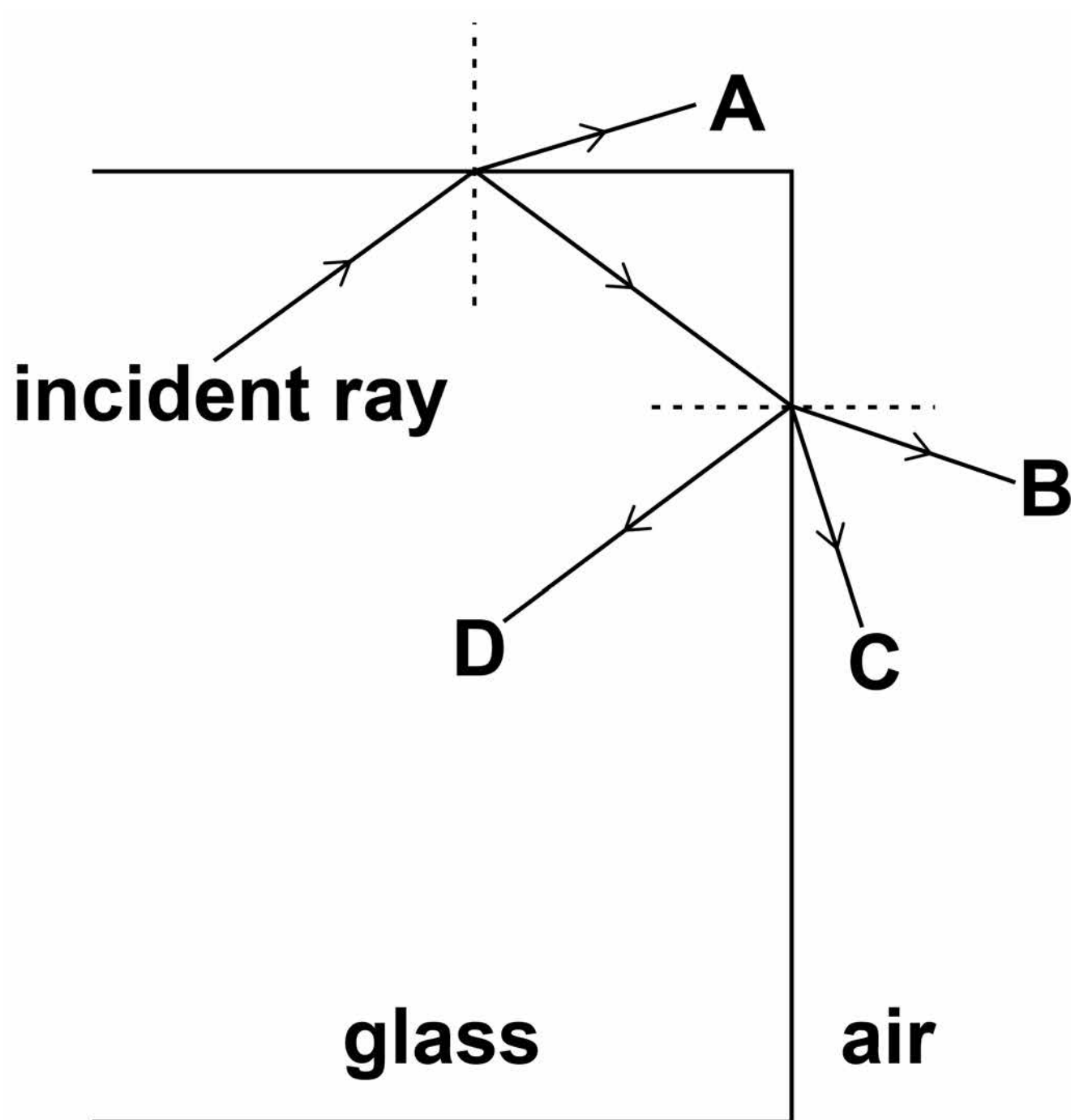

67

The refractive index of this glass is 1.5

The refractive index of air is 1.0

The angle of incidence of the light at the first glass–air boundary is 44°

What is the path of the ray of light?

[1 mark]

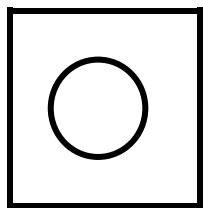

A

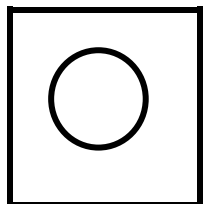

B

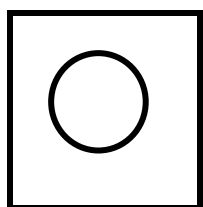

C

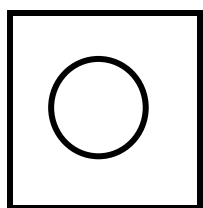

D

[Turn over]



1 6

Rays of light are incident at the same angle θ on the core–cladding boundary of optical fibres P and Q.

The cores of P and Q have the same refractive index n .

P and Q are the same length L .
The core diameter of P is half that of Q.

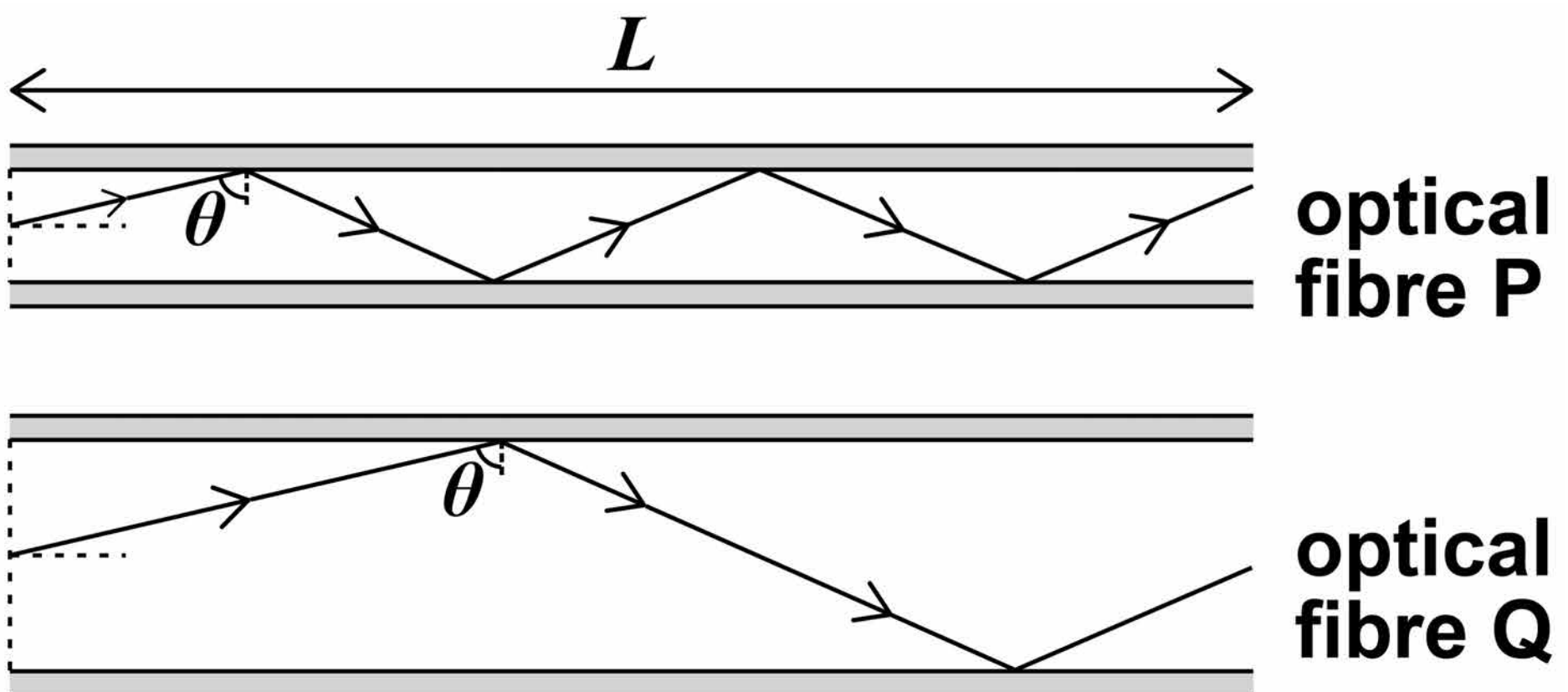

69

The time for the ray to travel along optical fibre P is

$$\frac{nL}{c \sin \theta}$$

where c is the speed of light in a vacuum.

What is the time for the ray to travel along optical fibre Q?
[1 mark]

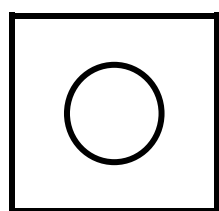

A $\frac{nL}{c \sin \theta}$

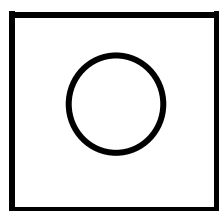

B $\frac{nL}{2c \sin \theta}$

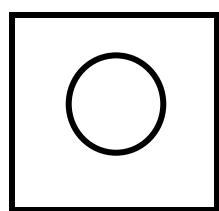

C $\frac{2nL}{c \sin \theta}$

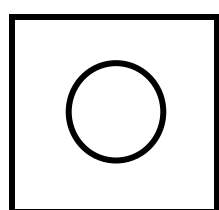

D $\frac{4nL}{c \sin \theta}$

[Turn over]



1	7
---	---

The fundamental frequency f is the lowest frequency heard when a stretched string is vibrating.

The string is now lightly touched one third of the way along its length.

What is the lowest frequency heard? [1 mark]

A $\frac{f}{3}$

B $\frac{2f}{3}$

C f

D $3f$



BLANK PAGE

[Turn over]



- 1 8** A diffraction grating is illuminated normally with light of wavelength $6.5 \times 10^{-7} \text{ m}$

When a screen is 1.5 m from the grating, the distance between the zero and first-order maxima on the screen is 0.30 m

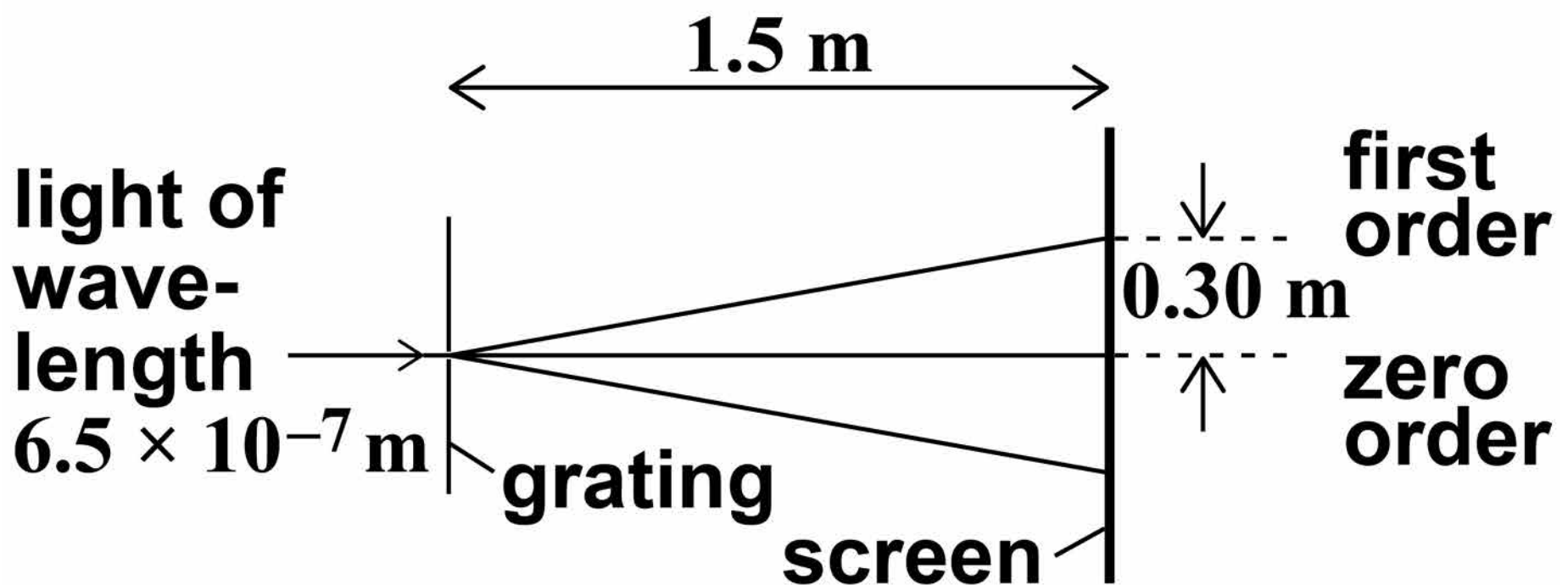

73

What is the number of lines per mm of the diffraction grating? [1 mark]

A 3.3×10^{-6}

B 3.3×10^{-3}

C 3.0×10^2

D 3.0×10^5

[Turn over]



1 9

Two points on a progressive wave have a phase difference of $\frac{\pi}{6}$ rad
The speed of the wave is 340 m s^{-1}

What is the frequency of the wave when the minimum distance between the two points is 0.12 m ? [1 mark]

A 240 Hz**B 470 Hz****C 1400 Hz****D 2800 Hz**

75

BLANK PAGE

[Turn over]



76

- 20** A bird sits on a uniform rod suspended from vertical wires P and Q.

The diagram is not drawn to scale.

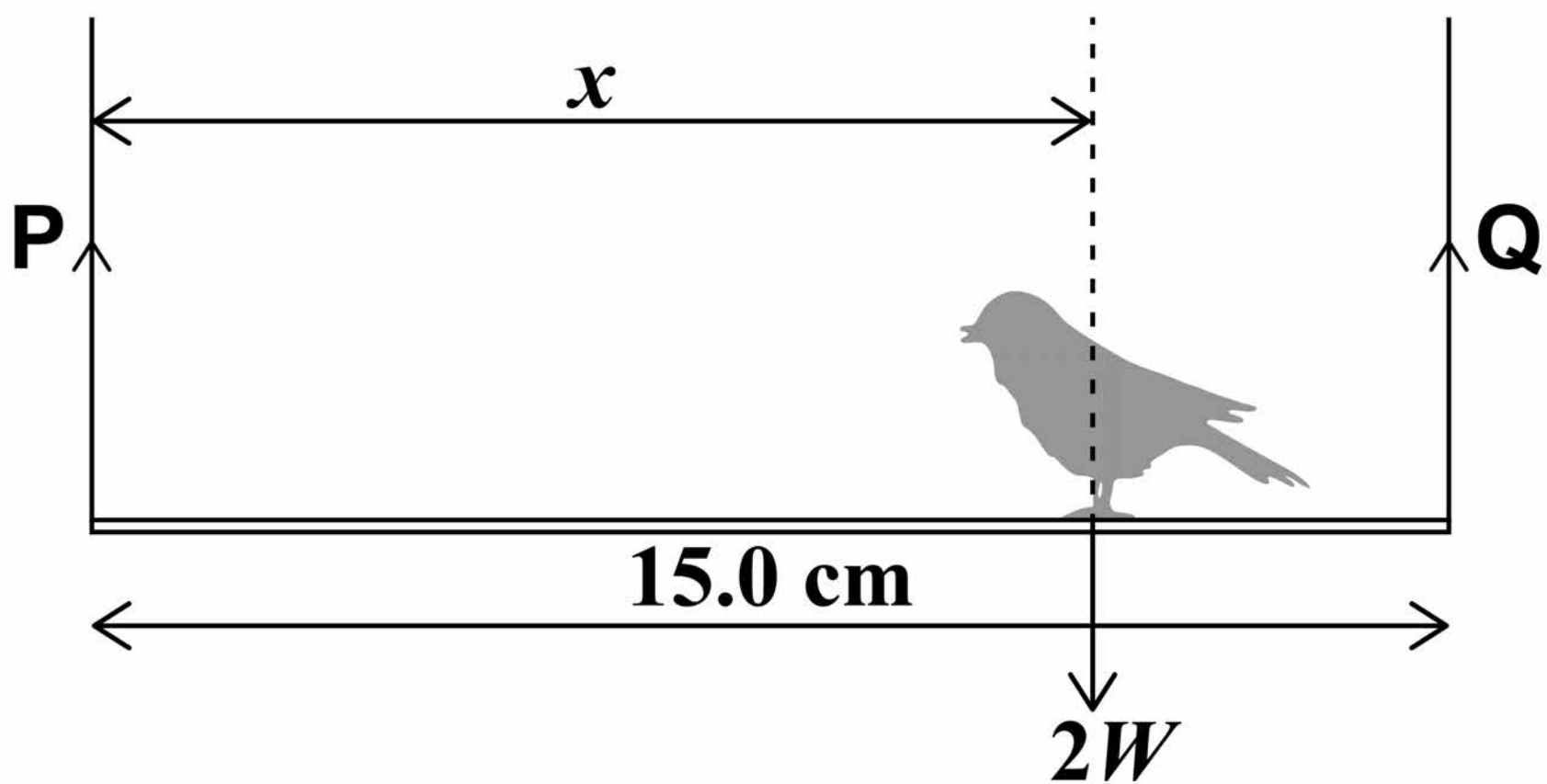

77

The rod has a weight W and is 15.0 cm long.

The weight of the bird is $2W$ and acts at a distance x from P.

What is the value of x when the tension in P is half the tension in Q?
[1 mark]

A 7.50 cm

B 10.0 cm

C 11.3 cm

D 15.0 cm

[Turn over]



78

2 1 A car's engine produces a useful output power of 6.5×10^4 W

The car of mass 950 kg is moving up a hill at a steady speed.

The slope of the hill is 12° to the horizontal. Resistive forces on the car are negligible.

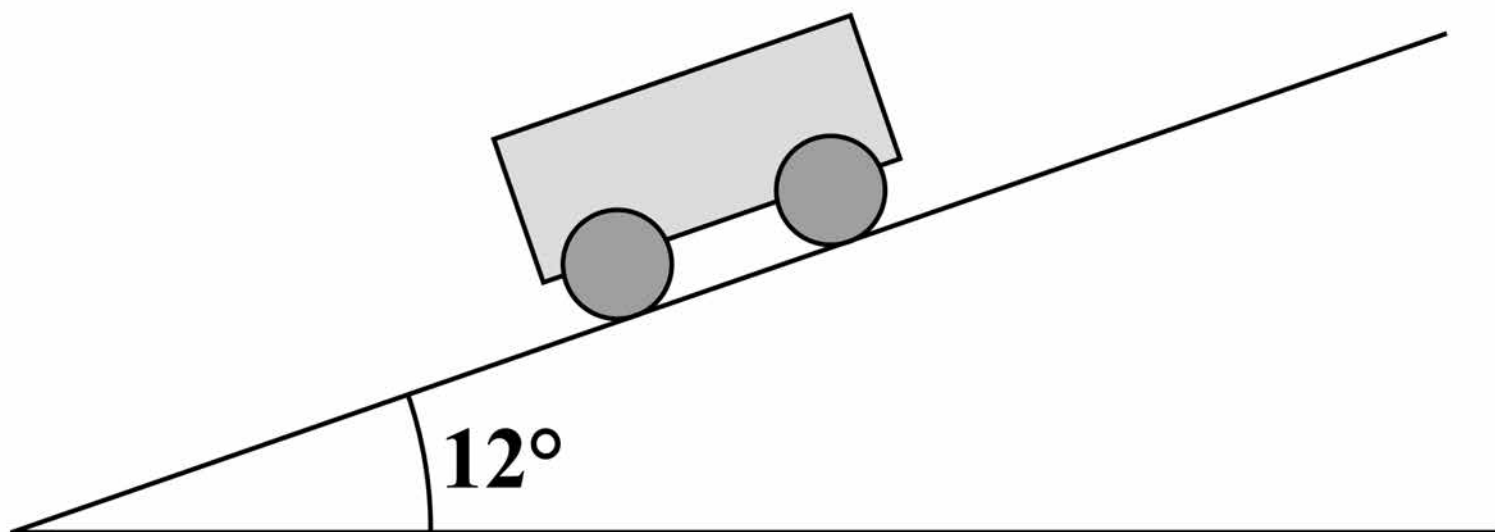

79

What is the steady speed of the car?
[1 mark]

A 7.0 m s^{-1} **B** 12 m s^{-1} **C** 34 m s^{-1} **D** 68 m s^{-1}

[Turn over]



2 2 A girl is bouncing on a trampoline.

Assuming that air resistance is negligible, her acceleration [1 mark]

A is zero when she is at maximum height.

B is constant when she is in the air.

C changes direction as she rises and then falls.

D is maximum just before she lands on the trampoline.



BLANK PAGE

[Turn over]



2 3 The table contains information on four wires. It shows the stiffness of each wire and the maximum strain energy stored in the wire when extended to the breaking point.

Assume each wire has the same initial dimensions and obeys Hooke's law.

Which wire extends the least before reaching the breaking point? [1 mark]

83

		Stiffness / N m^{-1}	Maximum strain energy / J
<input type="checkbox"/>	A	4.0	1
<input type="checkbox"/>	B	9.0	1
<input type="checkbox"/>	C	16	3
<input type="checkbox"/>	D	25	3

[Turn over]

2 4 Two spheres, P and Q, have the same volume but P has a greater mass. The spheres fall in air at their terminal velocities v_P and v_Q respectively.

Which row states the relationship between v_P and v_Q and the reason? [1 mark]

	Relationship between v_P and v_Q	Reason
<input type="checkbox"/> A	$v_P = v_Q$	Terminal velocity is unaffected by mass
<input type="checkbox"/> B	$v_Q > v_P$	The mass of Q is less and it accelerates more
<input type="checkbox"/> C	$v_Q > v_P$	P reaches equilibrium at a lower terminal velocity
<input type="checkbox"/> D	$v_P > v_Q$	Q reaches equilibrium at a lower terminal velocity

[Turn over]



- 2 5** An aircraft is flying due north through still air with a speed v . The aircraft enters a region where the wind is blowing with a speed u from a direction which makes an angle of θ with due south.

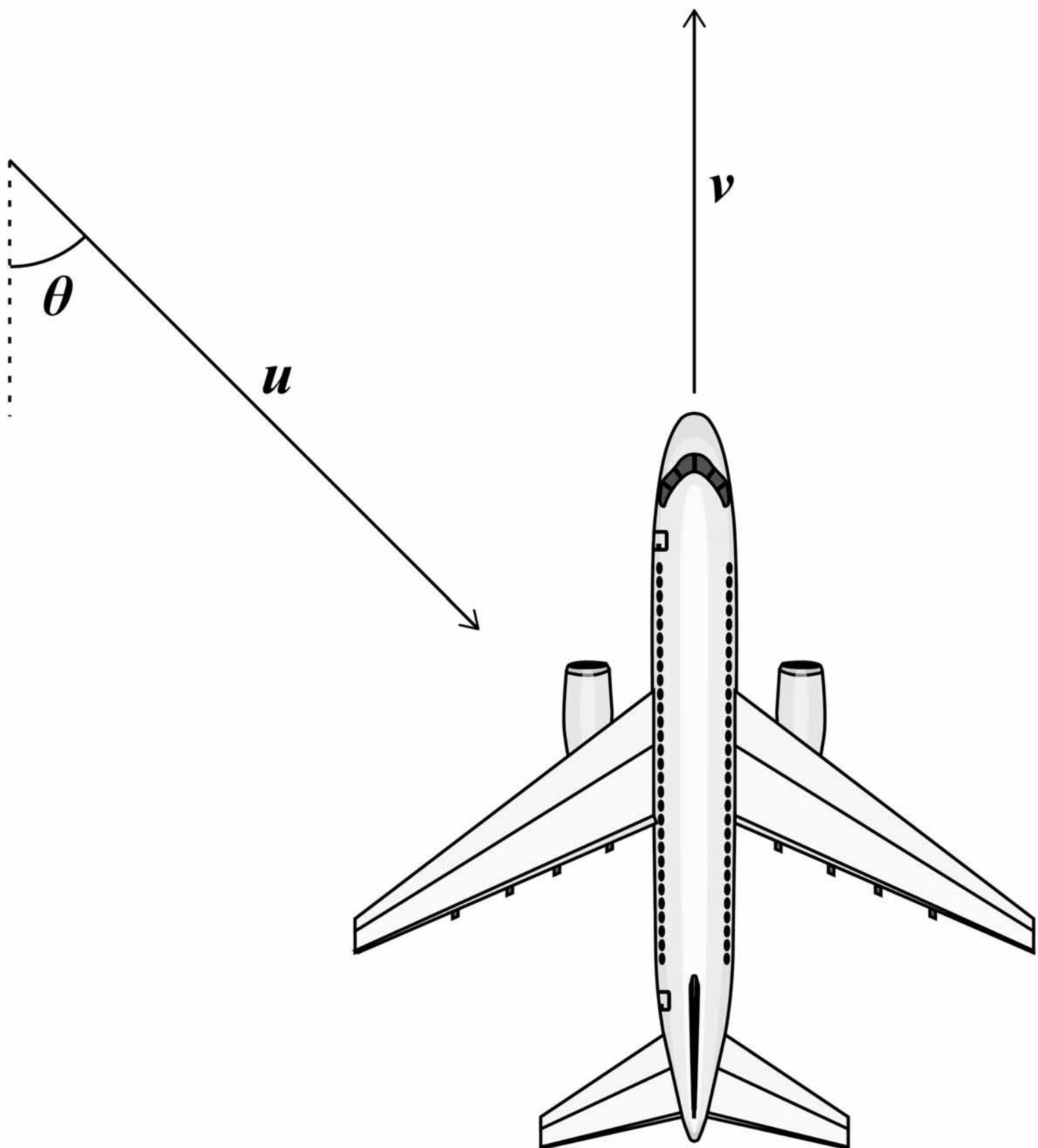

87

What is the time taken for the aircraft to fly a distance D due north of its current position in this windy region? [1 mark]

A $\frac{D}{v - u \cos\theta}$

B $\frac{D}{v - u \sin\theta}$

C $\frac{D}{v + u \cos\theta}$

D $\frac{D}{v + u \sin\theta}$

[Turn over]



- 2 6** The graph shows how the resultant force F on a football, which is initially at rest, varies with time t .

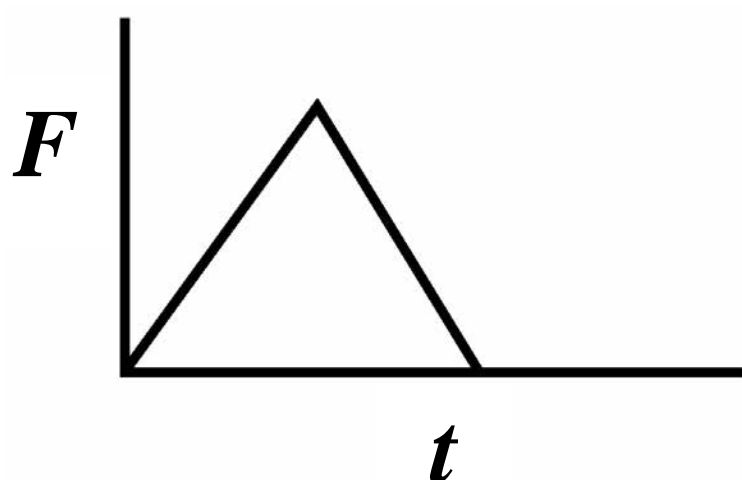

Which graph shows how the momentum p of the football varies with time t ? [1 mark]

A

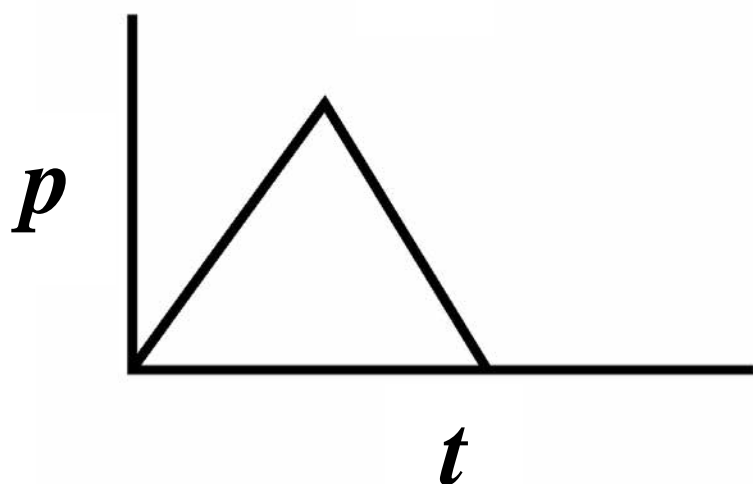

B

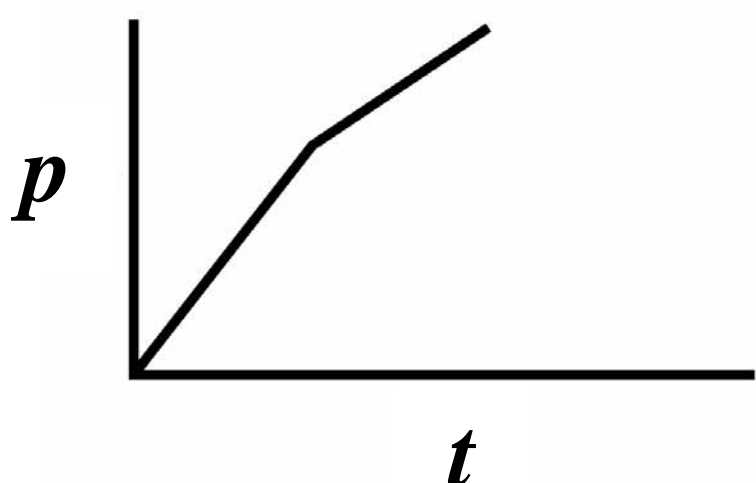

C

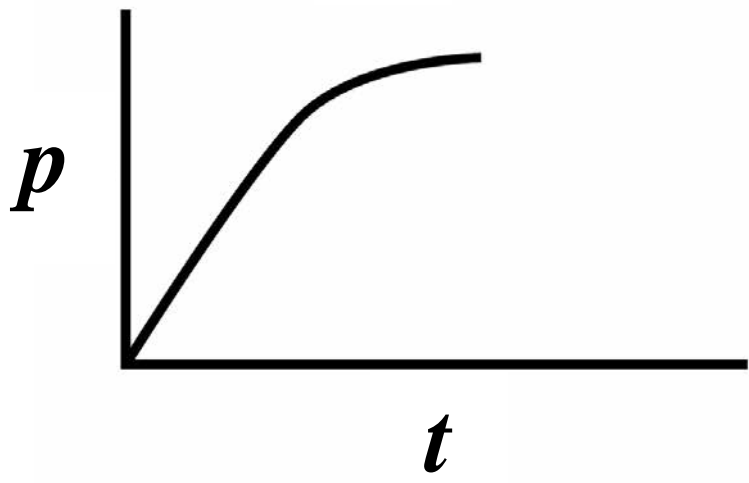

D

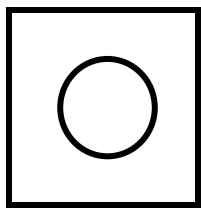
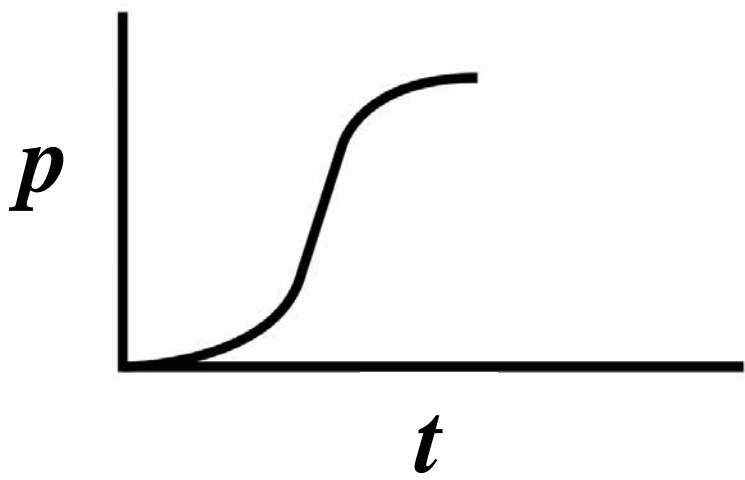

A

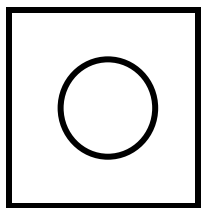

B

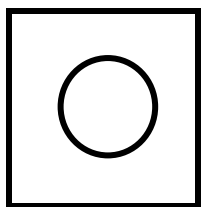

C

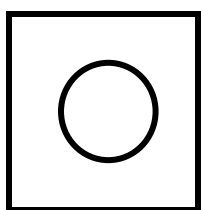

D

[Turn over]



90

27 Objects P and Q are initially at rest at time $t = 0$
The same resultant force F is applied to P and Q for time T .
The mass of P is 10 times greater than the mass of Q.

What is the ratio
 $\frac{\text{kinetic energy of P}}{\text{kinetic energy of Q}}$?

[1 mark]

A 0.1

B 1

C 10

D 100



BLANK PAGE

[Turn over]



- 2 8** Which graph shows how power dissipated P varies with current I in a component that obeys Ohm's law? [1 mark]

A

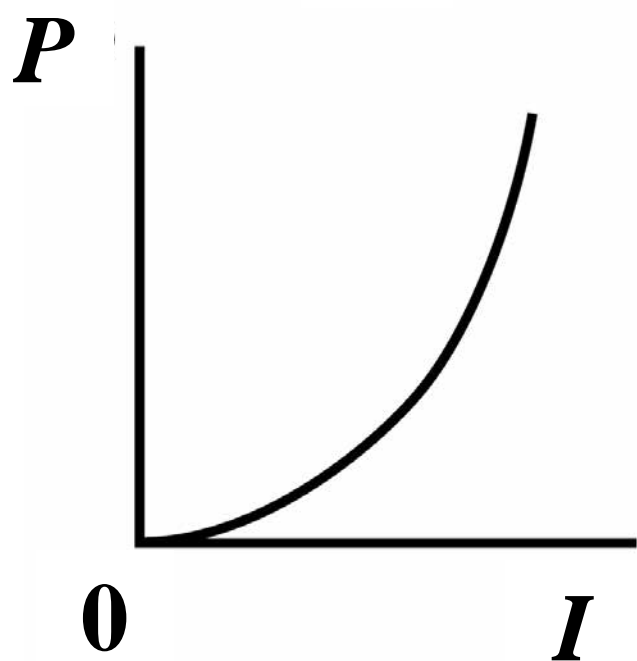

B

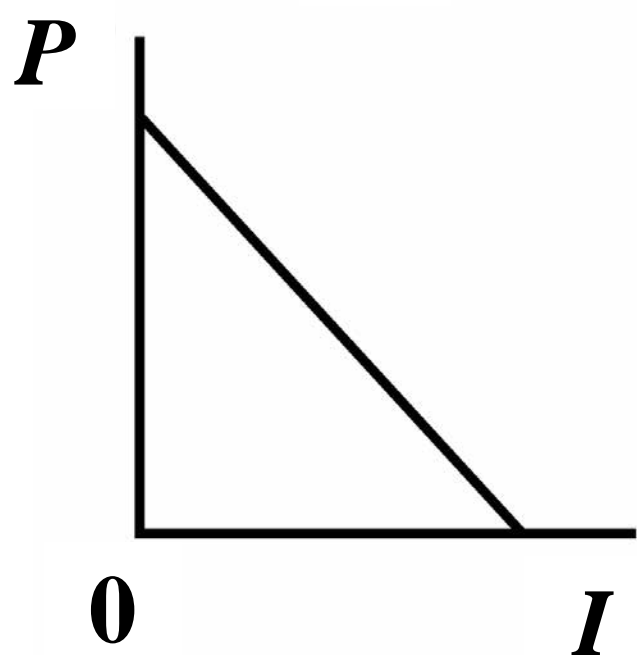

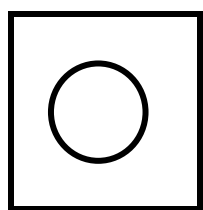
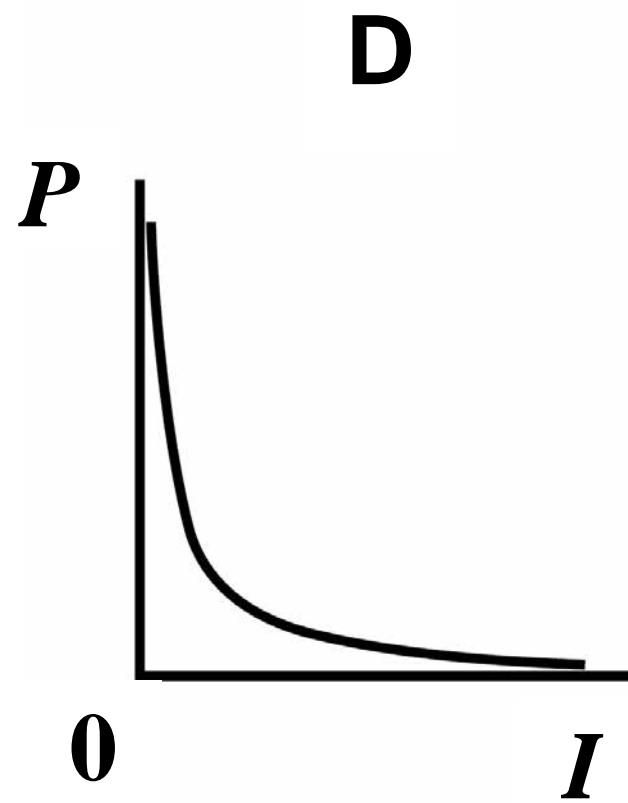
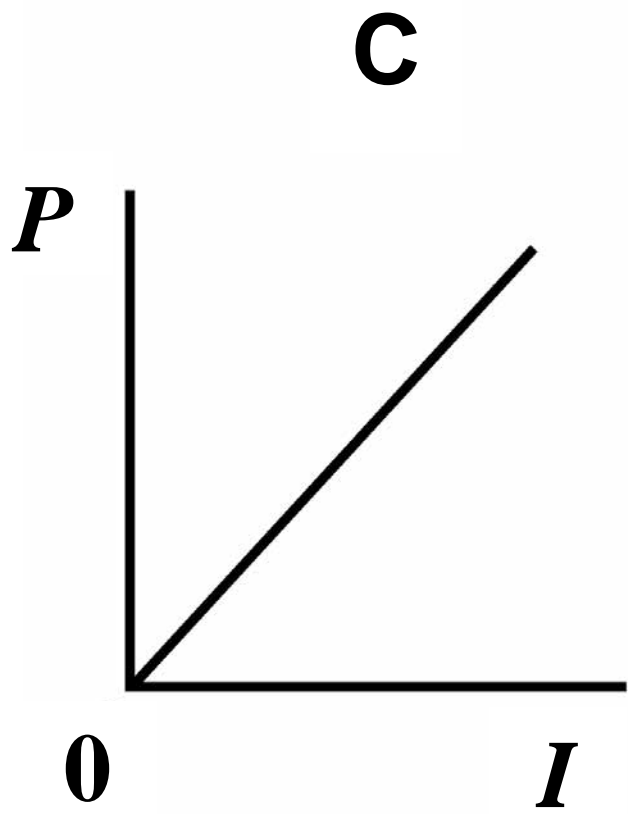

A

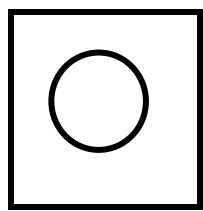

B

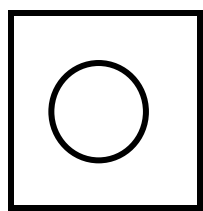

C

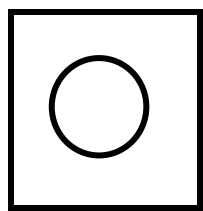

D



[Turn over]

BLANK PAGE



2 9 1.0 kilowatt-hour (kW h) is equivalent to

[1 mark]

A $6.3 \times 10^{18} \text{ eV}$

B $6.3 \times 10^{21} \text{ eV}$

C $2.3 \times 10^{22} \text{ eV}$

D $2.3 \times 10^{25} \text{ eV}$

[Turn over]



3 0 The graph shows how the potential difference V across an electrical component varies with current I in the component.

A tangent has been drawn on the curve at point P for a current of I_2 .

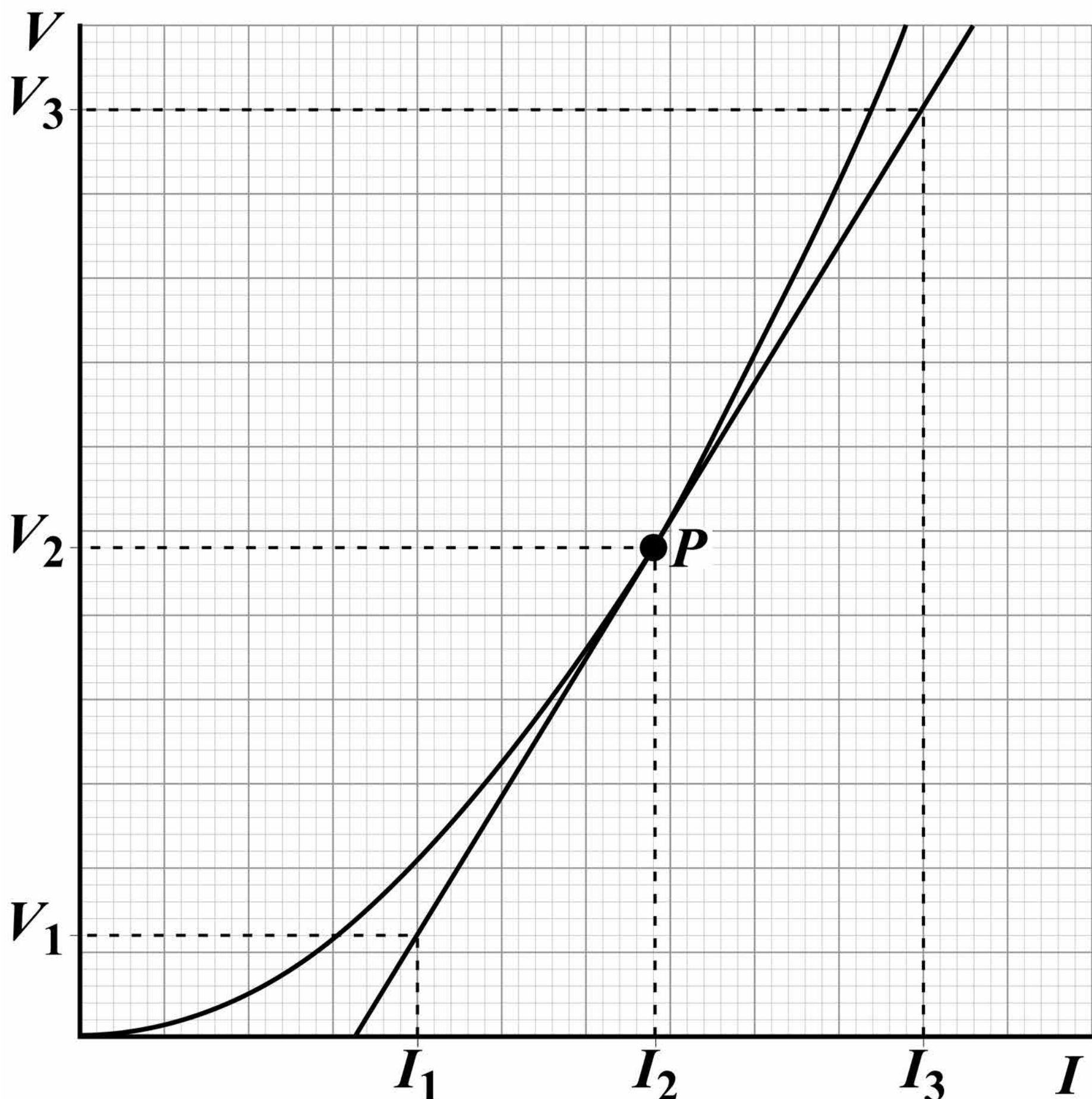

What is the resistance of the electrical component when the current in the component is I_2 ?
[1 mark]

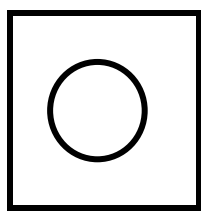

A $\frac{V_3 - V_1}{2I_2}$

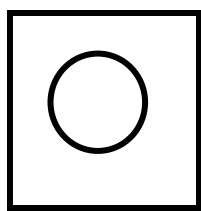

B $\frac{V_3 - V_1}{I_3 - I_1}$

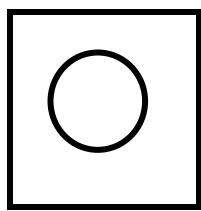

C $\frac{V_2}{I_2}$

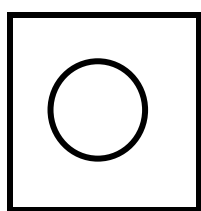

D $\frac{2V_2}{I_2 - I_1}$

[Turn over]



98

3 1

A circuit consists of a cell, a thermistor, a fixed resistor and two ammeters.

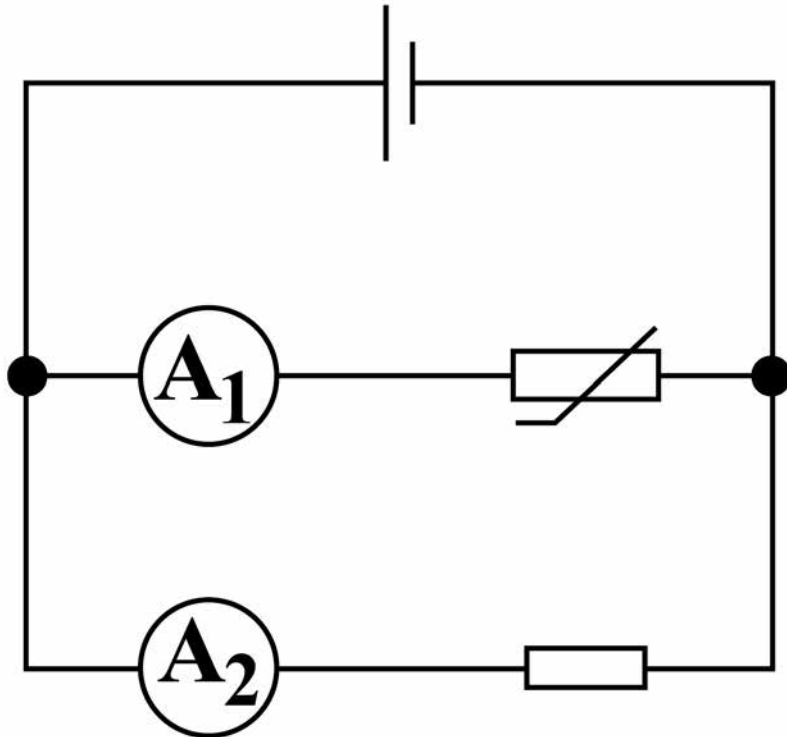

The cell has a constant electromotive force and negligible internal resistance. Readings from the two ammeters are taken.



Which row describes what happens to the current in each ammeter when the temperature of the thermistor decreases? [1 mark]

		Current in ammeter A_1	Current in ammeter A_2
<input type="checkbox"/>	A	Decreases	Unchanged
<input type="checkbox"/>	B	Decreases	Increases
<input type="checkbox"/>	C	Increases	Decreases
<input type="checkbox"/>	D	Increases	Unchanged

[Turn over]



- 3 2** A circuit consists of two identical cells, a resistor, an ammeter and a voltmeter. The cells each have an emf of 3.0 V and the resistor has a resistance of $12\ \Omega$. The cells have negligible internal resistance.

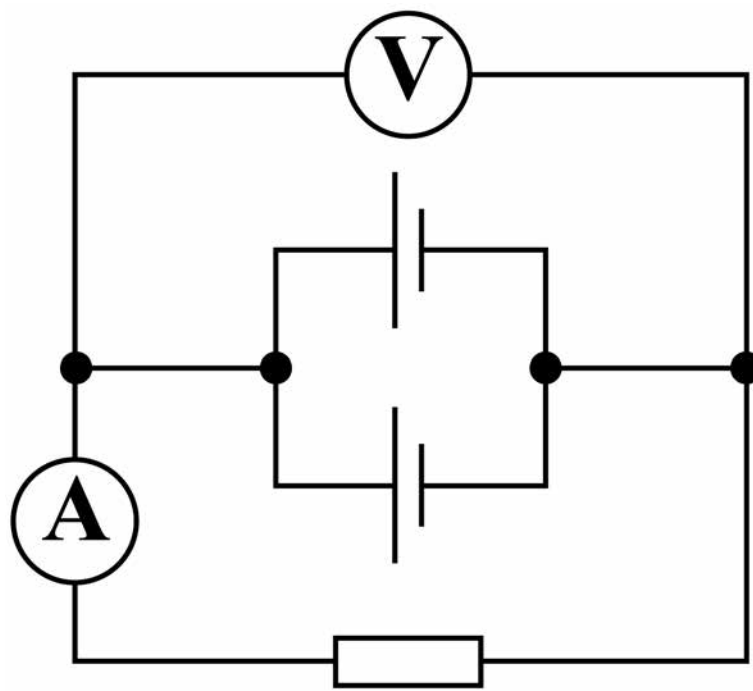

101

**Which row shows the readings on the voltmeter and ammeter?
[1 mark]**

		Voltage / V	Current / A
<input type="checkbox"/>	A	3.0	0.25
<input type="checkbox"/>	B	3.0	0.50
<input type="checkbox"/>	C	6.0	0.25
<input type="checkbox"/>	D	6.0	0.50

[Turn over]



3	3
---	---

Which is equivalent to the ohm?
[1 mark]

A $\text{J C}^{-2} \text{s}^{-1}$

B $\text{J C}^{-2} \text{s}$

C J s

D J s^{-1}



BLANK PAGE

[Turn over]



- 3 4** The circuit shows a cell with negligible internal resistance connected in a circuit with three resistors, an ammeter and a voltmeter.

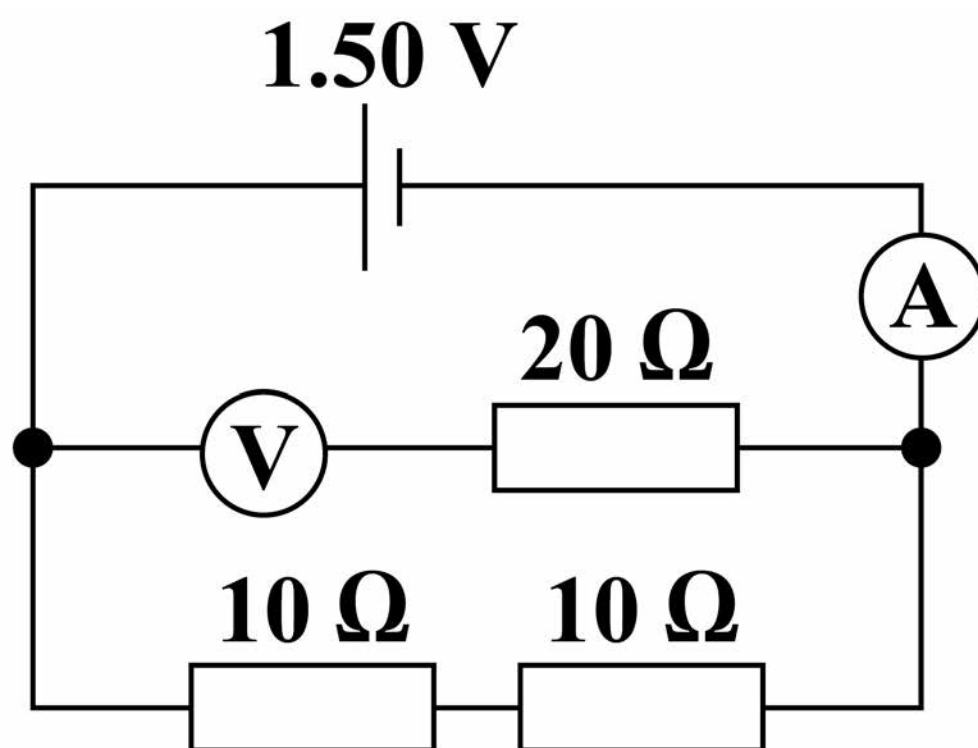

105

Which row shows the readings on the ammeter and voltmeter?

[1 mark]

		Current / A	Voltage / V
<input type="checkbox"/>	A	0.075	0.75
<input type="checkbox"/>	B	0.075	1.50
<input type="checkbox"/>	C	0.150	0.75
<input type="checkbox"/>	D	0.150	1.50

END OF QUESTIONS



There are no questions printed on this page

For Examiner's Use	
Question	Mark
1	
2	
3	
4	
5–34	
TOTAL	

Copyright information

For confidentiality purposes, from the November 2015 examination series, acknowledgements of third party copyright material will be published in a separate booklet rather than including them on the examination paper or support materials. This booklet is published after each examination series and is available for free download from www.aqa.org.uk after the live examination series.

Permission to reproduce all copyright material has been applied for. In some cases, efforts to contact copyright-holders may have been unsuccessful and AQA will be happy to rectify any omissions of acknowledgements. If you have any queries please contact the Copyright Team, AQA, Stag Hill House, Guildford, GU2 7XJ.

Copyright © 2018 AQA and its licensors. All rights reserved.

IB/M/Jun18/IK/7407/2/E4

