



Surname _____

Other Names _____

Centre Number _____

Candidate Number _____

Candidate Signature _____

GCSE

COMBINED SCIENCE: TRILOGY

F

Foundation Tier

Chemistry Paper 2F

8464/C/2F

Wednesday 13 June 2018

Morning

Time allowed: 1 hour 15 minutes

For this paper you must have:

- a ruler
- a scientific calculator
- the periodic table (enclosed).

At the top of the page, write your surname and other names, your centre number, your candidate number and add your signature.

[Turn over]



J U N 1 8 8 4 6 4 C 2 F 0 1

BLANK PAGE



INSTRUCTIONS

- Use black ink or black ball-point pen.
- Answer ALL questions in the spaces provided. Do not write on blank pages.
- Do all rough work in this book. Cross through any work you do not want to be marked.
- In all calculations, show clearly how you work out your answer.

INFORMATION

- The maximum mark for this paper is 70.
- The marks for questions are shown in brackets.
- You are expected to use a calculator where appropriate.
- You are reminded of the need for good English and clear presentation in your answers.

DO NOT TURN OVER UNTIL TOLD TO DO SO



0	1
---	---

FIGURE 1 represents an atom of sulfur.

FIGURE 1



0	1
---	---

1

Complete TABLE 1 [1 mark]

TABLE 1

Particle	Number of particles in a sulfur atom
Electron	16
Neutron	
Proton	16



0 1 . 2 Sulfur is in Group 6 of the periodic table.

Complete the electronic structure of the sulfur atom represented in FIGURE 2 [1 mark]

FIGURE 2

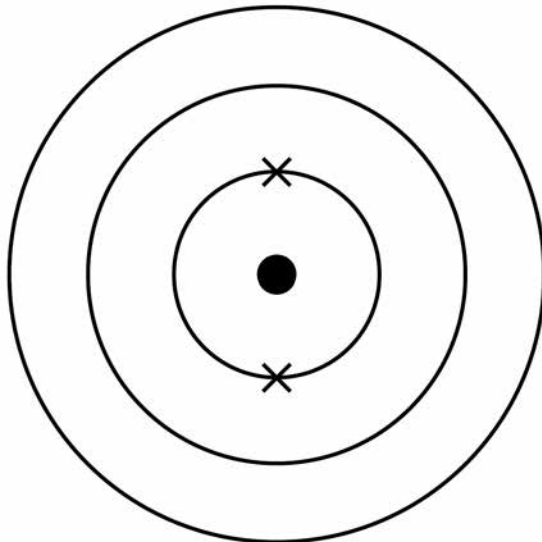

0 1 . 3 Sulfur reacts with oxygen to produce sulfur dioxide.

Complete the word equation for this reaction.
[1 mark]

sulfur + _____

[Turn over]



0 1 . 4 What effect is caused by sulfur dioxide?
[1 mark]

Tick ONE box.

Acid rain

Global dimming

Global warming

Sea levels rising



BLANK PAGE

[Turn over]



01.5 FIGURE 3 shows the mass of sulfur dioxide in the Earth's atmosphere between 1984 and 2014

FIGURE 3

Mass of sulfur dioxide in kilotonnes

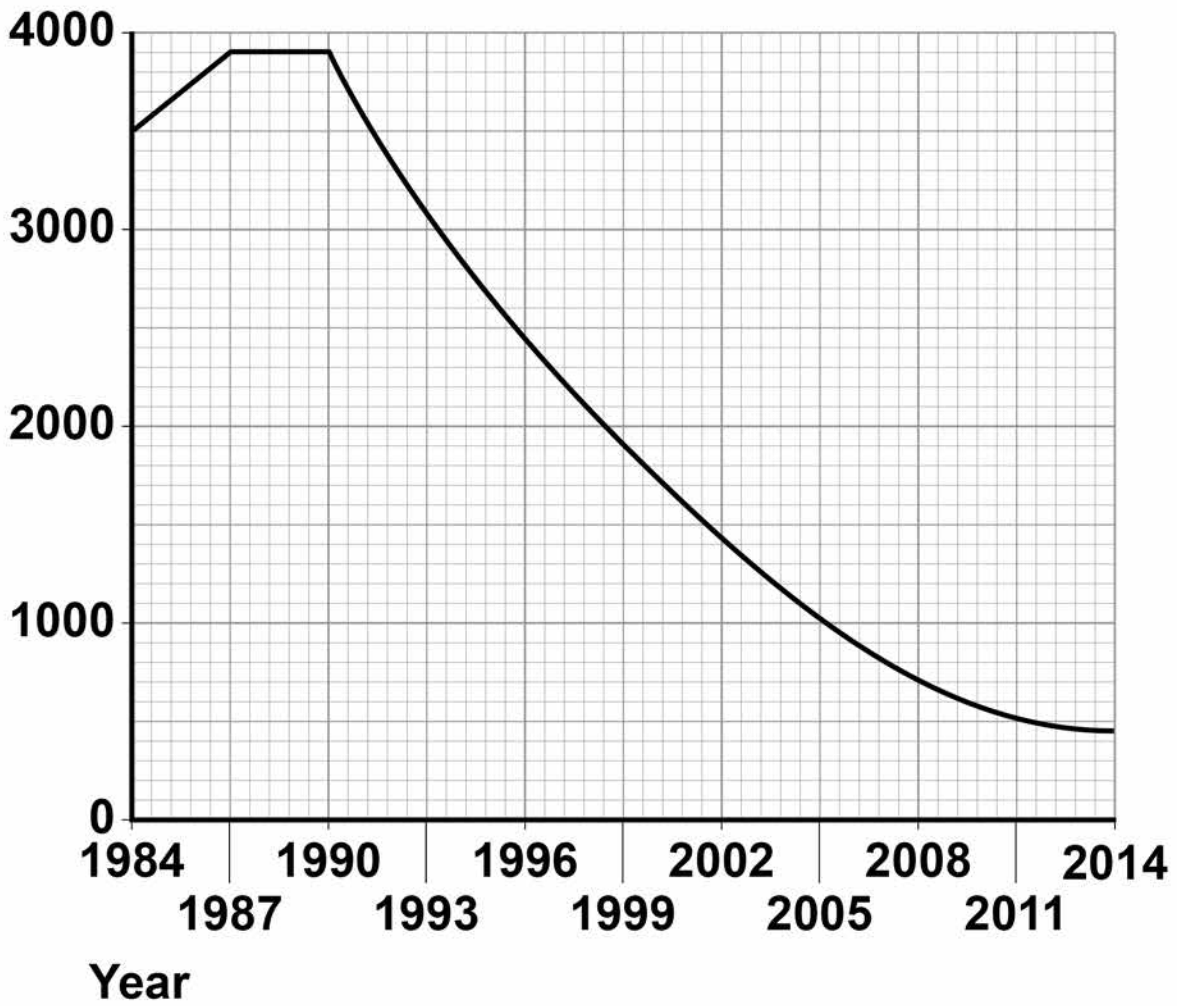

0 1 . 6 FIGURE 4 shows the percentage of sulfur dioxide released by human activities.

FIGURE 4

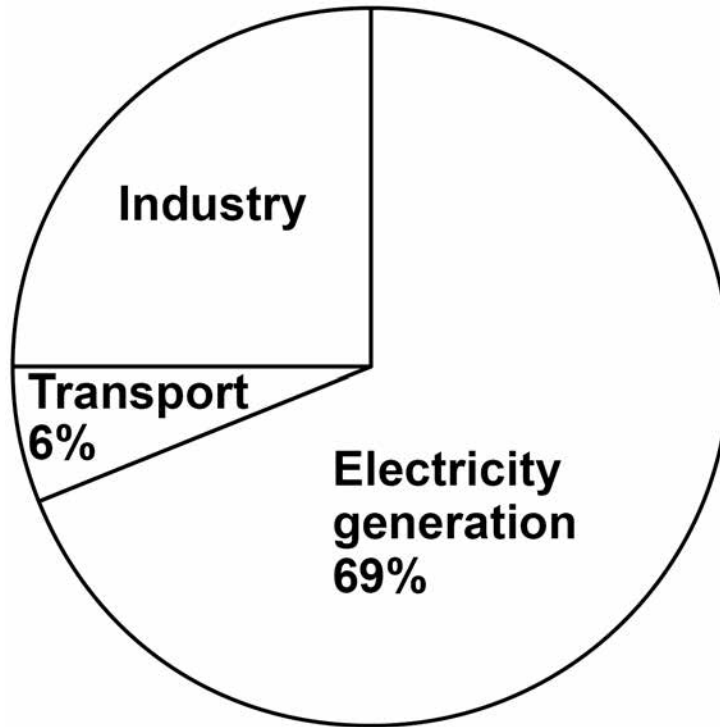

Calculate the percentage of sulfur dioxide released by industry. [2 marks]

Percentage = _____ %

9



BLANK PAGE

[Turn over]



0 2

A student used paper chromatography to identify the colours in a black ink.

FIGURE 5 shows the student's results.

FIGURE 5

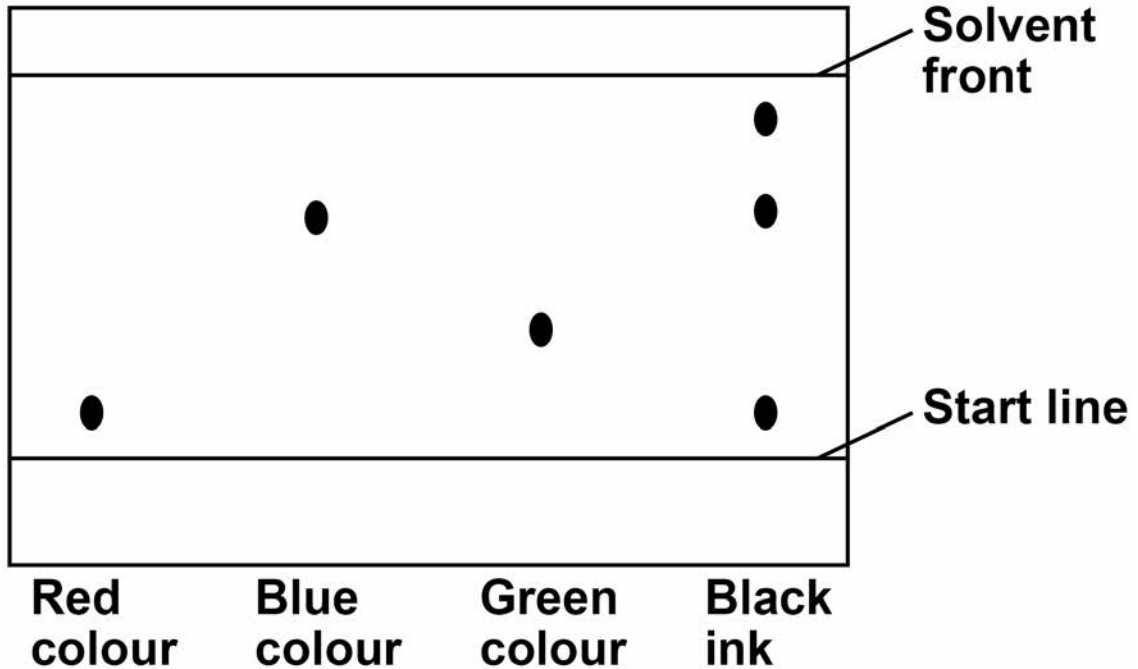

0 2 . 1 What colours are in the black ink? [2 marks]



0 2 . 2 Suggest which colour is least soluble in the solvent.

Give a reason for your answer. [2 marks]

Colour _____

Reason _____

0 2 . 3 Use FIGURE 5, on page 12, to complete TABLE 2

TABLE 2

	Distance in mm
Distance moved by green colour	
Distance moved by solvent	

[Turn over]



BLANK PAGE



15

Calculate the R_f value for the green colour.
Use the equation:

$$R_f = \frac{\text{distance moved by green colour}}{\text{distance moved by solvent}}$$

[4 marks]

R_f value = _____

[Turn over]

8



03

A student tested a sea water sample for dissolved solids.

FIGURE 6 shows the apparatus.

FIGURE 6

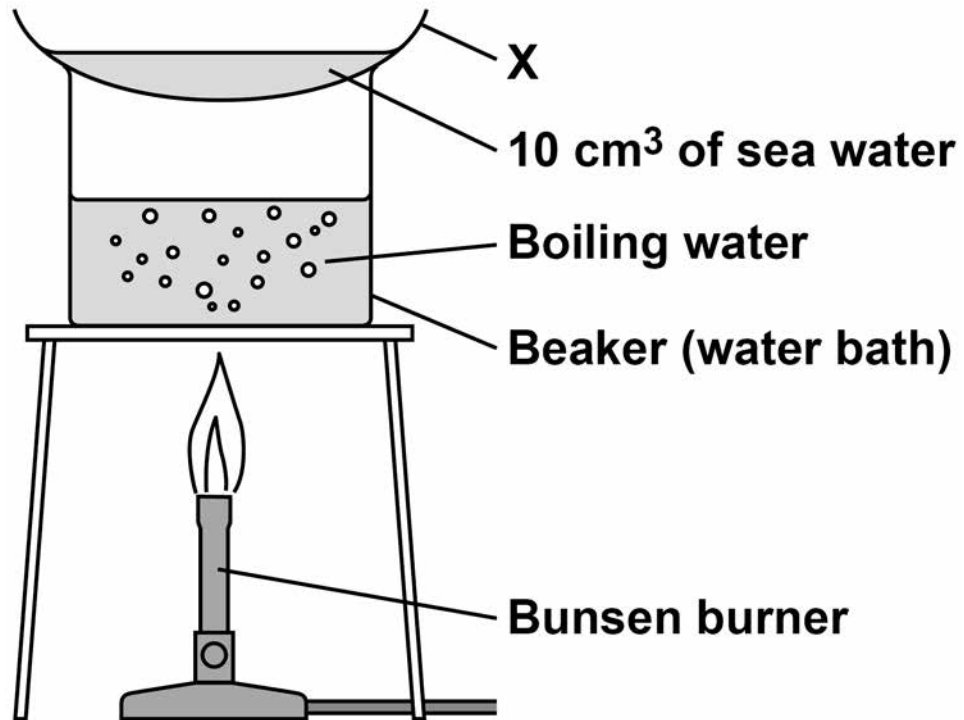

03.1 What is apparatus X on FIGURE 6? [1 mark]

Tick ONE box.

Boiling tube

Condenser

Funnel

Watch glass

[Turn over]



03.2 The student did the test four times.

The student calculated the mass of solid on apparatus X after heating.

TABLE 3 shows the student's results.

TABLE 3

	Test 1	Test 2	Test 3	Test 4
Mass of solid in grams	0.12	0.29	0.14	0.15

Calculate the mean mass of solid.

Do not include the anomalous result in your calculation.

Give your answer to 2 significant figures.

[3 marks]



Mean mass = _____ g

[Turn over]



The student distilled a sample of sea water in the apparatus shown in FIGURE 7

FIGURE 7

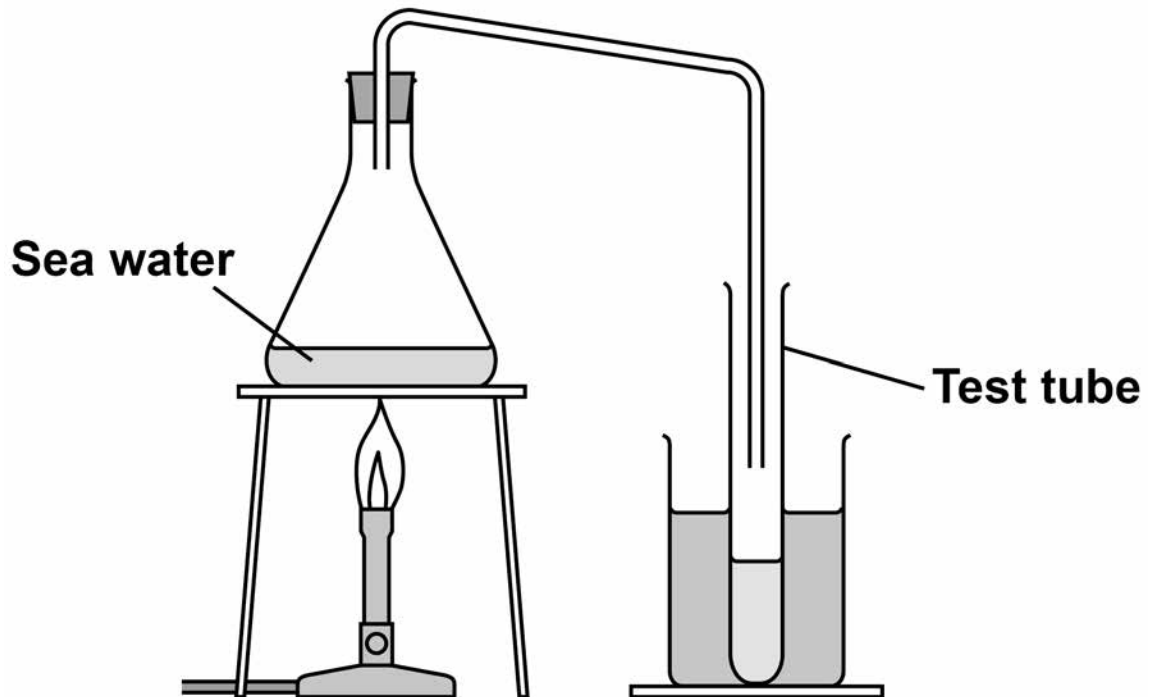

0 3 . 3 What change of state is happening at the surface of the sea water in FIGURE 7?
[1 mark]

0 3 . 4 Describe how the water in the test tube in FIGURE 7 is different from the sea water.
[1 mark]



0 3 . 5 Why does producing drinking water from sea water using distillation cost a lot of money?
[1 mark]

0 3 . 6 River water is filtered then sterilised to make drinking water.

Why are these TWO processes done?
[2 marks]

Filtering

Sterilising

[Turn over]

9



0 4 . 1 What percentage of the Earth's atmosphere is nitrogen? [1 mark]

Tick ONE box.

5%

20%

50%

80%

0 4 . 2 During the first billion years of the Earth's existence the amount of nitrogen in the atmosphere increased.

Give ONE source of this nitrogen. [1 mark]



0 4 . 3 Nitrogen is used to make ammonia.

The word equation for the reaction is:

nitrogen + hydrogen _____ ammonia

Write the correct symbol in the equation to show that it is a reversible reaction. [1 mark]

0 4 . 4 A reversible reaction can reach equilibrium.

Complete the sentence. [1 mark]

Equilibrium is reached when the forward reaction and the reverse reaction happen at the same _____.

0 4 . 5 Fertilisers are formulations containing nitrogen.

What is a formulation? [1 mark]

[Turn over]



04.6 TABLE 4 shows percentages of chemical elements in a fertiliser.

TABLE 4

Element	Percentage (%)
Nitrogen (N)	7.0
Phosphorus (P)	3.1
Potassium (K)	5.8



25

Draw the bar for potassium on FIGURE 8

Use the information in TABLE 4. [1 mark]

FIGURE 8

Percentage of
element (%)

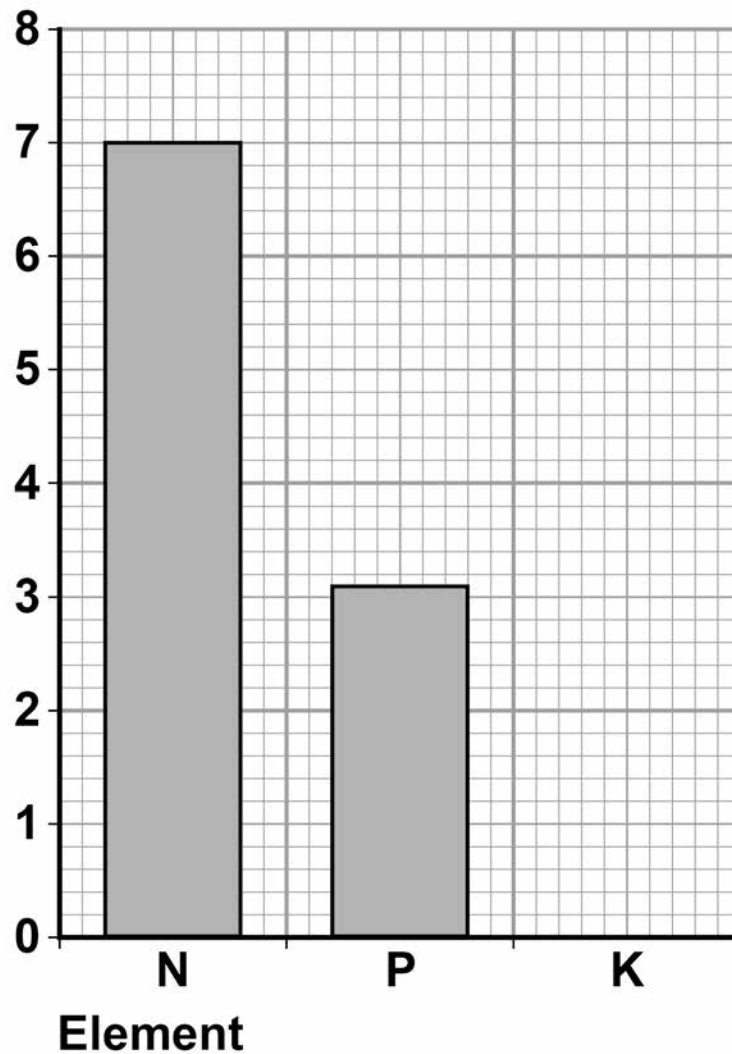

[Turn over]



BLANK PAGE



04.7 A fertiliser contains 0.225 g of iron per 3.0 g of fertiliser.

Which calculation gives the percentage of iron in the fertiliser? [1 mark]

Tick ONE box.

$$\frac{0.225}{3.0 \times 100}$$

$$\frac{3.0 \times 100}{0.225}$$

$$\frac{0.225 \times 3.0}{100}$$

$$\frac{0.225 \times 100}{3.0}$$

[Turn over]



04.8 FIGURE 9 shows the use of fertiliser in four different countries, A, B, C and D, in 2003 and 2015

FIGURE 9

Mass of fertiliser used per hectare in kg

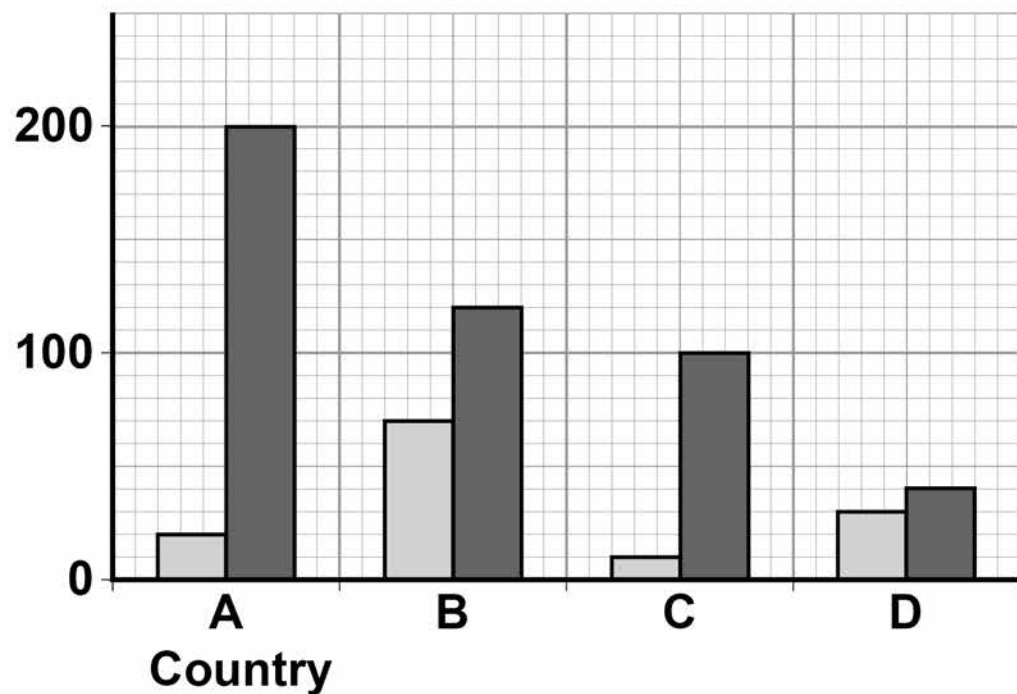

KEY

2003

2015



05

A student investigated the effect of the size of marble chips on the rate of the reaction between marble chips and hydrochloric acid.

This is the method used.

1. Add 10.0 g of marble chips into the flask.
2. Add 50 cm³ of hydrochloric acid and start a timer.
3. Record the mass lost from the flask every 10 seconds.
4. Repeat steps 1 to 3 with different sizes of marble chips.

FIGURE 10 shows the apparatus.

FIGURE 10

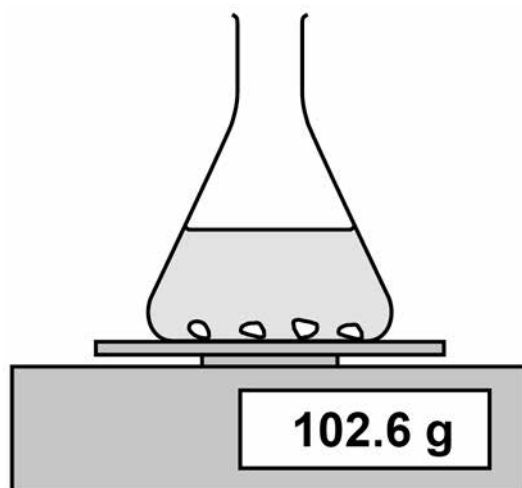

0 5 . 1 Draw **ONE** line from each type of variable to the correct example of the variable. [2 marks]

Type of variable

Example of variable

	Mass lost from flask
Independent	Size of flask
	Size of marble chips
Control	Time taken
	Volume of acid

[Turn over]



0 5 . 2 The equation for the reaction is:



Name the THREE products. [2 marks]

1 _____

2 _____

3 _____

0 5 . 3 Another student suggests putting some cotton wool in the top of the flask.

**Suggest why this improves the investigation.
[1 mark]**



05.4 The reaction produces 1.6 g of gas in 30 seconds.

Calculate the mean rate of the reaction in the first 30 seconds.

Use the equation:

$$\text{mean rate of reaction} = \frac{\text{mass of product produced in grams}}{\text{time in seconds}}$$

[1 mark]

Mean rate of reaction = _____

[Turn over]



BLANK PAGE



05.5 What is the unit for the mean rate of reaction calculated in question 05.4? [1 mark]

Tick ONE box.

g

g/s

s

s/g

[Turn over]



05.6 TABLE 5 shows the student's results.

TABLE 5

Time in seconds	Mass of gas produced in g
0	0.0
10	0.8
20	0.6
30	1.6
40	1.8
50	2.0
60	2.0



Plot the data from TABLE 5 on FIGURE 11

Draw a line of best fit. [3 marks]

FIGURE 11

Mass
of gas
produced
in g

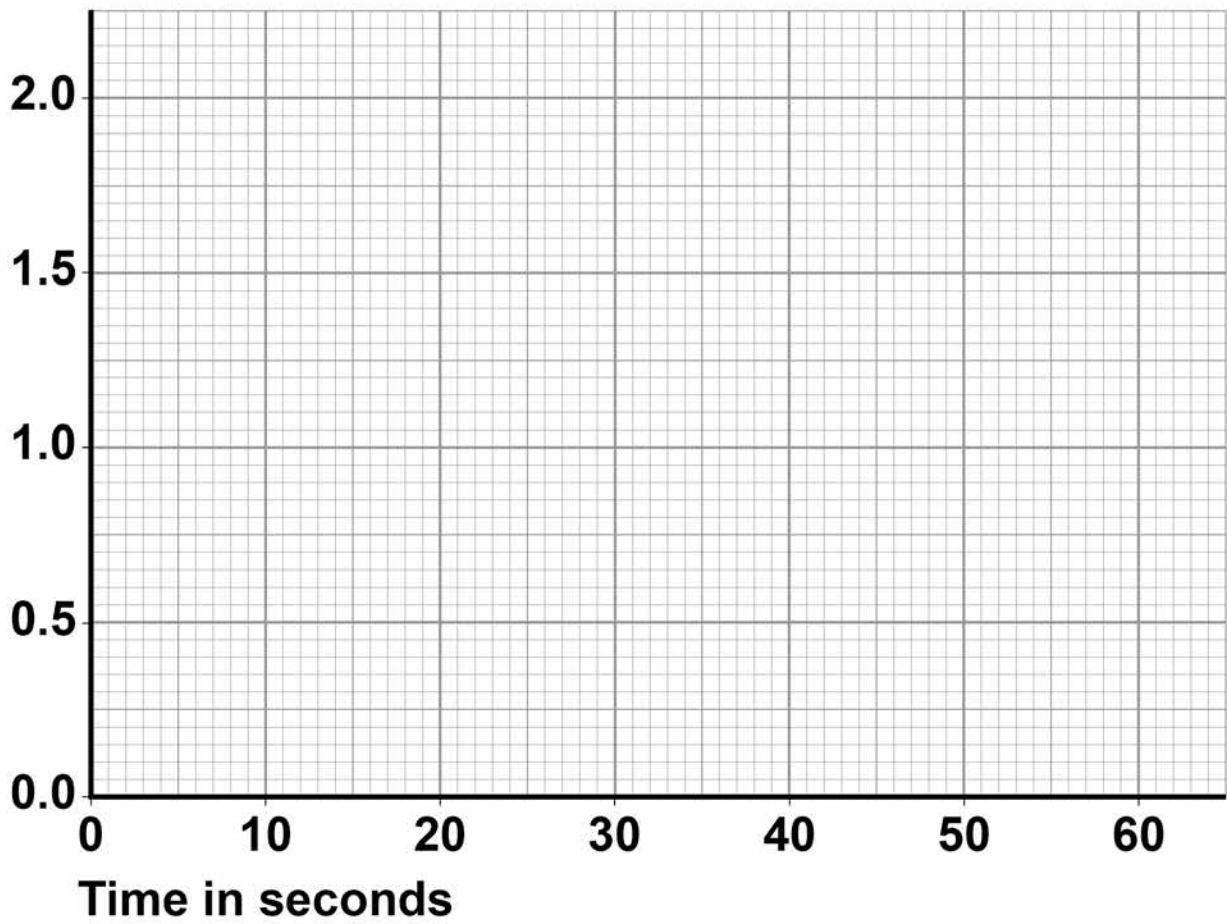

[Turn over]



05.7 FIGURE 12 shows a large marble chip and eight small marble chips.

FIGURE 12

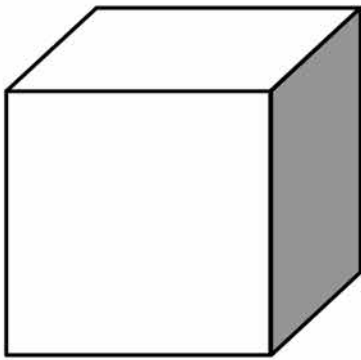

Large marble chip

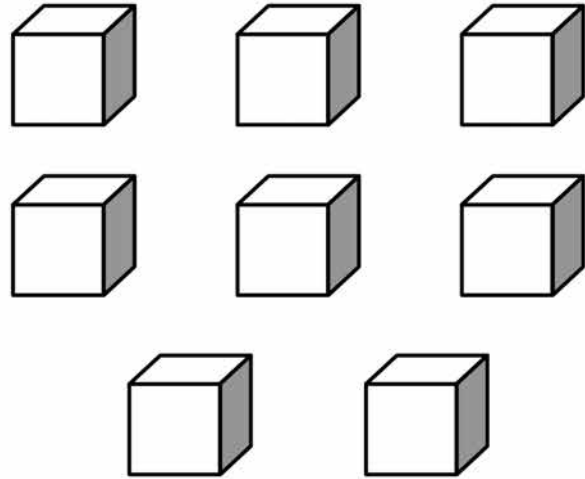

Eight small marble chips

The large marble chip has the same total volume as the eight small marble chips, but a different surface area.



Why do the eight small marble chips react faster than the large marble chip? [1 mark]

Tick ONE box.

The eight small marble chips have a larger surface area, so less frequent collisions.

The eight small marble chips have a larger surface area, so more frequent collisions.

The eight small marble chips have a smaller surface area, so less frequent collisions.

The eight small marble chips have a smaller surface area, so more frequent collisions.

[Turn over]

11



06

Crude oil is a mixture of hydrocarbons.

06

.1

The hydrocarbons in crude oil are separated into fractions by fractional distillation.

FIGURE 13 shows a fractional distillation column.

FIGURE 13

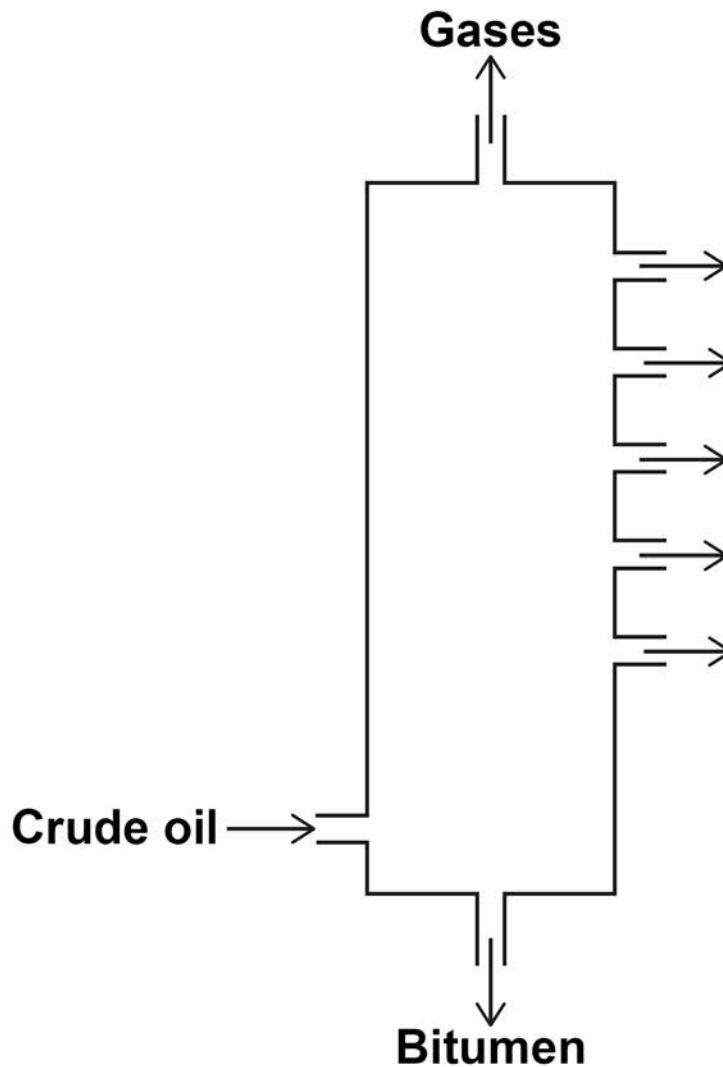

41

Crude oil vapour passes up the column.

Complete the sentence.

Choose the answer from the list. [1 mark]

- condenses
- dissolves
- freezes
- melts

Each fraction _____

at a different level.

[Turn over]



06.2 Why do the fractions separate? [1 mark]

Tick ONE box.

The fractions have different boiling points.

The fractions have different flammability.

The fractions have different melting points.

The fractions have different viscosity.



Most of the hydrocarbons in crude oil are alkanes.

0 6 . 3 FIGURE 14 represents an alkane molecule.

FIGURE 14

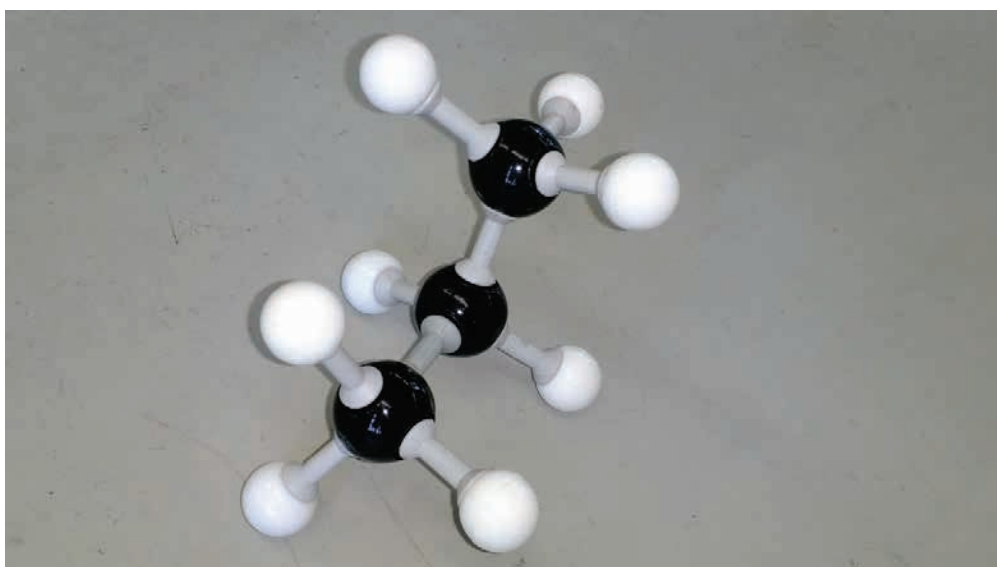

Name the alkane. [1 mark]

[Turn over]



06.4 Methane (CH₄) is an alkane.

What is the general formula for alkanes?
[1 mark]

Tick ONE box.

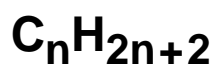
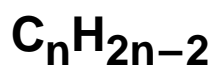
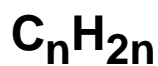

06.5 Alkanes burn in oxygen.

Balance the equation for methane burning.
[1 mark]

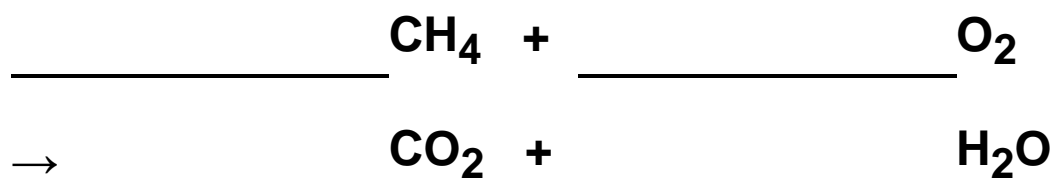

06.6 Ethene is an alkene.

**Which reagent is used to test for alkenes?
[1 mark]**

Tick ONE box.

Anhydrous copper sulfate

Bromine water

Damp litmus paper

Limewater

[Turn over]



TABLE 6 shows data from a life cycle assessment (LCA) for the disposal of 10 000 biodegradable plastic bags.

TABLE 6

	Burning and using the energy to generate electricity	Landfill
Mass of carbon dioxide produced in kg	25	15
Mass of solid residue in kg	0.050	0.070
Mass of sulfur dioxide produced in kg	0.20	0.30

06.7 Why are life cycle assessments (LCA) done?
[1 mark]



07

This question is about the Earth's atmosphere.

07.1

Carbon dioxide is a greenhouse gas.

What is another greenhouse gas? [1 mark]

Tick ONE box.

Argon

Methane

Nitrogen

Oxygen



07.2 Greenhouse gases cause global climate change.

**Give TWO effects of global climate change.
[2 marks]**

1 _____

2 _____

[Turn over]



07.3 4.1 kg of a plastic, used to make plastic bottles, has a carbon footprint of 6.0 kg of carbon dioxide.

Calculate the carbon footprint of ONE plastic bottle of mass 23.5 g [2 marks]

Carbon footprint =

_____ **kg of carbon dioxide**

07.4 Give ONE way that carbon dioxide emissions can be reduced when a plastic bottle is manufactured. [1 mark]



There are no questions printed on this page



There are no questions printed on this page

For Examiner's Use	
Question	Mark
1	
2	
3	
4	
5	
6	
7	
TOTAL	

Copyright information

For confidentiality purposes, from the November 2015 examination series, acknowledgements of third party copyright material will be published in a separate booklet rather than including them on the examination paper or support materials. This booklet is published after each examination series and is available for free download from www.aqa.org.uk after the live examination series.

Permission to reproduce all copyright material has been applied for. In some cases, efforts to contact copyright-holders may have been unsuccessful and AQA will be happy to rectify any omissions of acknowledgements. If you have any queries please contact the Copyright Team, AQA, Stag Hill House, Guildford, GU2 7XJ.

Copyright © 2018 AQA and its licensors. All rights reserved.

IB/M/Jun18/AMAS/8464/C/2F/E3

