

A

AQA 

Surname _____

Other Names _____

Centre Number _____

Candidate Number _____

Candidate Signature _____

GCSE

COMBINED SCIENCE: SYNERGY

Foundation Tier Paper 2

Life and environmental sciences

F

8465/2F

Wednesday 23 May 2018

Afternoon

Time allowed: 1 hour 45 minutes

At the top of the page, write your surname and other names, your centre number, your candidate number and add your signature.

[Turn over]



For this paper you must have:

- **a ruler**
- **a scientific calculator**
- **the periodic table (enclosed)**
- **the Physics Equations Sheet (enclosed).**

INSTRUCTIONS

- **Use black ink or black ball-point pen.**
- **Answer ALL questions in the spaces provided. Do not write on blank pages.**
- **Do all rough work in this book. Cross through any work you do not want to be marked.**
- **In all calculations, show clearly how you work out your answer.**



INFORMATION

- **The maximum mark for this paper is 100.**
- **The marks for questions are shown in brackets.**
- **You are expected to use a calculator where appropriate.**
- **You are reminded of the need for good English and clear presentation in your answers.**

DO NOT TURN OVER UNTIL TOLD TO DO SO



4

0	1
---	---

An argon atom can be

represented as ${}_{18}^{40}\text{Ar}$

0	1	.	1
---	---	---	---

What does the number 40

represent in ${}_{18}^{40}\text{Ar}$? [1 mark]



5

01.2 How many protons does this atom of argon have? [1 mark]

Tick ONE box.

18

22

40

58

[Turn over]



6

01.3 How many neutrons does this atom of argon have? [1 mark]

Tick ONE box.

18

22

40

58



7

FIGURE 1 shows the energy levels (shells) in a neon atom.

FIGURE 1

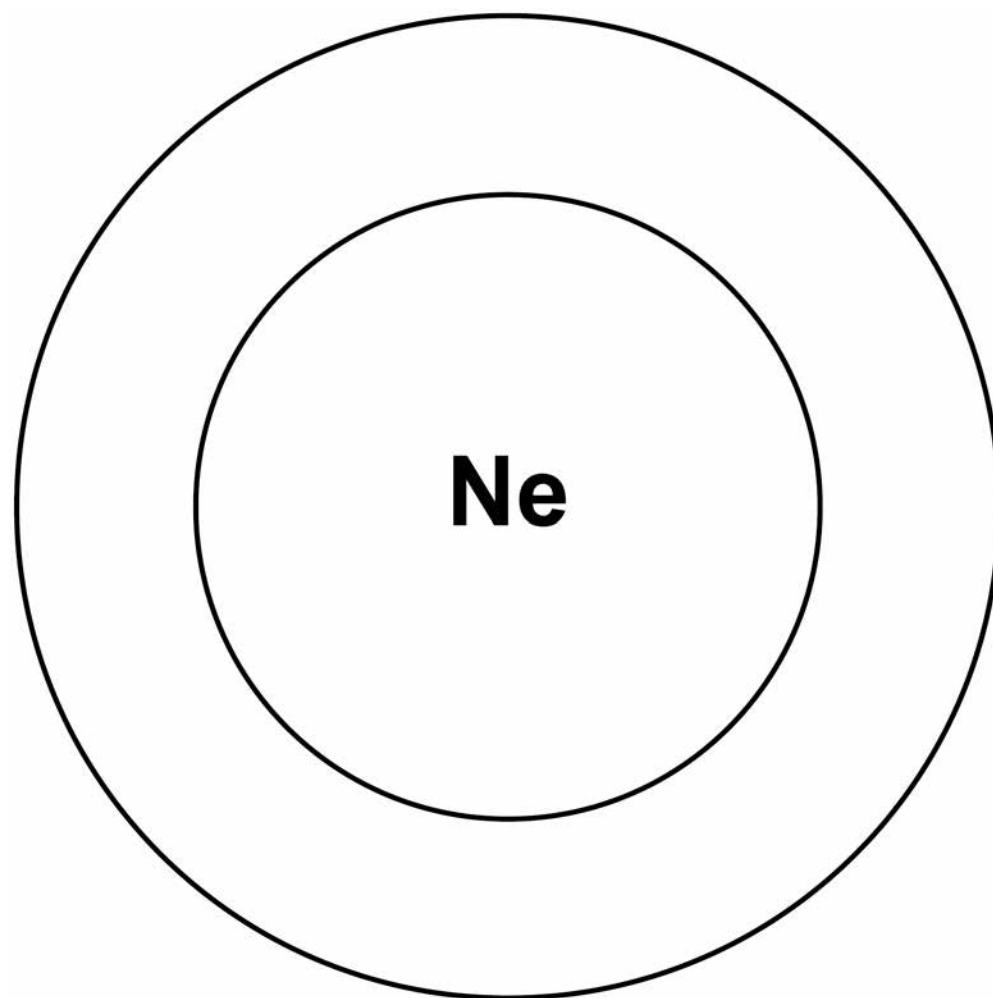

0 1 . 4 A neon atom has 10 electrons.

Complete FIGURE 1 to show the electronic structure of a neon atom.

Use X to represent an electron.
[1 mark]

[Turn over]



8

01.5 The nucleus of a neon atom has a charge.

What is the charge? [1 mark]

Tick ONE box.

Negative

Neutral

Positive



01.6 A neon atom has 10 protons,
10 electrons and 10 neutrons.

**Explain why there is no overall
charge on a neon atom. [2 marks]**

[Turn over]



10

01.7 There are two different types of neon atom.

What are these different types of atom called? [1 mark]

Tick ONE box.

Compounds

Ions

Isotopes

Molecules



01.8 Neon is a gas.

The states of matter can be shown by a simple particle model.

Draw ONE line from each state of matter to the correct particle model. [2 marks]

State of matter Particle model

Gas

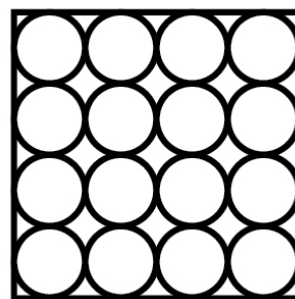

Liquid

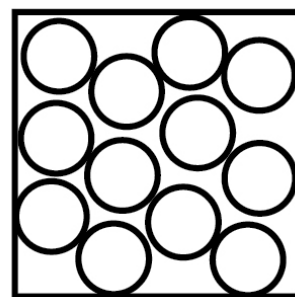

Solid

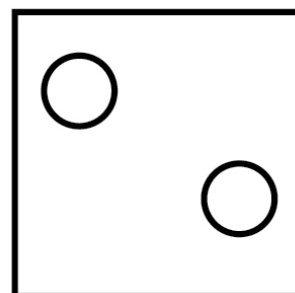

[Turn over]



12

0 2

Muscle cells divide to form new muscle cells.

0 2.1

Which TWO cell components are copied before the muscle cells start to divide? [2 marks]

Tick TWO boxes.

Cytoplasm

Mitochondria

Plasmids

Ribosomes

Vacuole



13

0 2 . 2 Why do muscle cells need to divide by mitosis more often than most other cells? [1 mark]

Tick ONE box.

To contract the muscles

To repair the muscles

To supply more oxygen to the muscles

To transmit nerve impulses

[Turn over]



Mitosis is part of the cell cycle.

FIGURE 2 shows the percentage of time taken by each stage of a cell cycle.

FIGURE 2

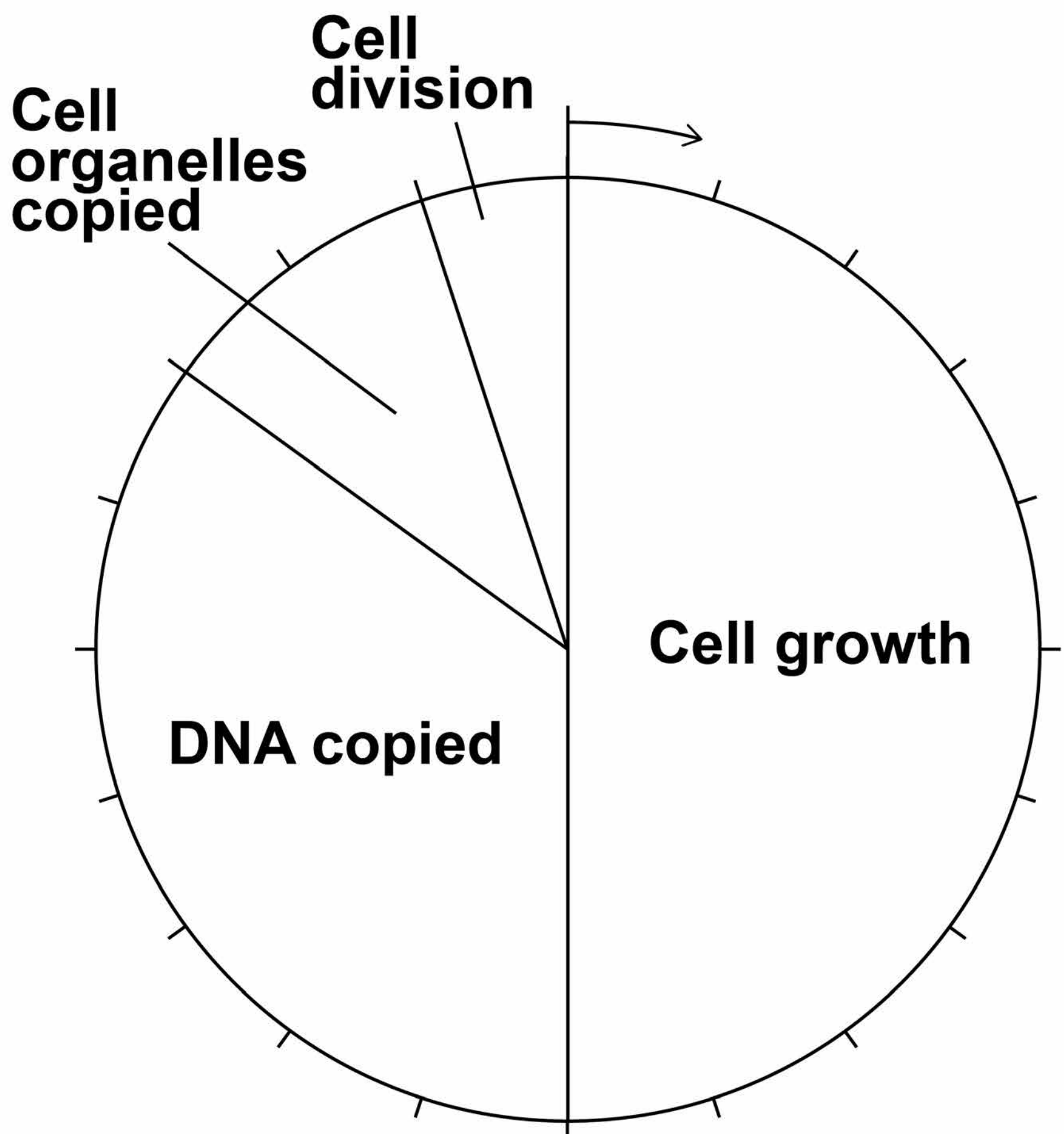

15

0 2 . 3 The cell cycle shown in FIGURE 2, on page 14, takes 21 hours in total.

Cell division takes 5% of the total time.

Calculate how many hours cell division takes. [2 marks]

Time taken = _____ hours

0 2 . 4 What percentage of time is spent copying DNA in the cell cycle shown in FIGURE 2, on page 14? [2 marks]

Percentage = _____

[Turn over]



16

0 2 . 5 A sperm cell from a dog contains 39 chromosomes.

**How many chromosomes are there in each dog muscle cell?
[1 mark]**

Tick ONE box.

39

78

156

312



17

0 2 . 6 A sperm cell fuses with an egg cell.

**What is this process called?
[1 mark]**

Tick ONE box.

Fertilisation

Meiosis

Ovulation

Respiration

[Turn over]

9



03

In 2017 more than 420 million people worldwide had diabetes.

TABLE 1 shows how the percentage of the population with diabetes has changed.

TABLE 1

Year	Percentage of population with diabetes		
	Low-income countries	High-income countries	World
1986	3.5	5.5	5.1
1992	4.4	5.9	5.8
1998	5.2	6.2	6.6
2004	6.0	6.5	7.2
2010	6.9	6.9	8.0



BLANK PAGE

[Turn over]



03.1 Use data from TABLE 1, on page 18, to complete the graph in FIGURE 3, on page 21, opposite.

You should:

- **plot the data for the low-income countries**
- **draw a line of best fit for the low-income countries.**

The lines for high-income countries and the world have been drawn for you. [3 marks]

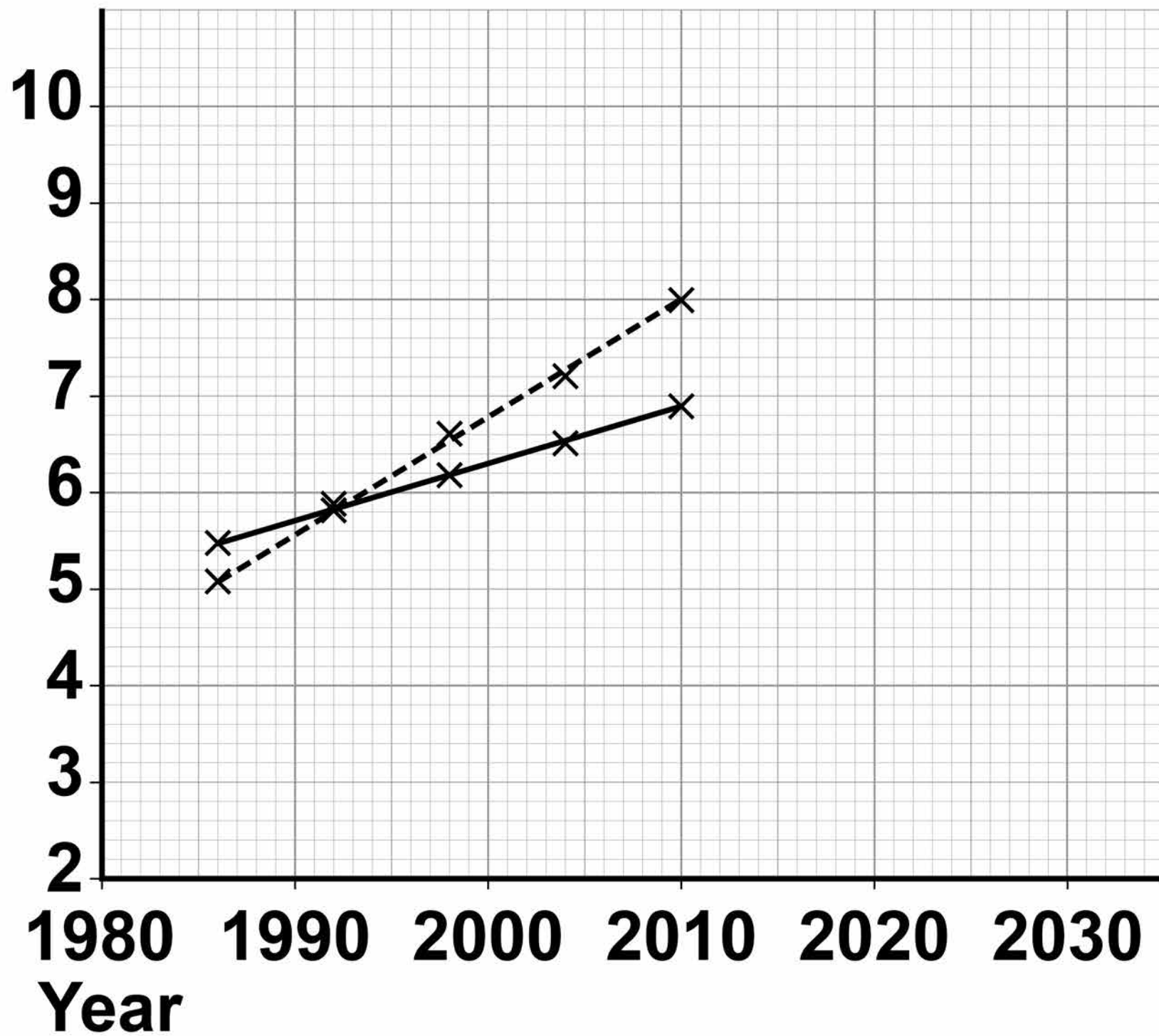

FIGURE 3**Percentage
of population
with diabetes****KEY**

— High-income countries

---- World

[Turn over]



03.2 Predict the percentage of the world population with diabetes in 2022 if the current pattern were to continue.

You should extend the line of best fit for the world on the graph in FIGURE 3, on page 21. [2 marks]

Percentage = _____ %



23

03.3 The trend may NOT continue in the same pattern after 2010.

Suggest ONE reason why the trend may change. [1 mark]

03.4 Give TWO conclusions from the data shown in FIGURE 3, on page 21. [2 marks]

1

2

[Turn over]



Repeat of TABLE 1

Year	Percentage of population with diabetes		
	Low-income countries	High-income countries	World
1986	3.5	5.5	5.1
1992	4.4	5.9	5.8
1998	5.2	6.2	6.6
2004	6.0	6.5	7.2
2010	6.9	6.9	8.0



25

03.5 TABLE 1, on page 24, shows that the percentage of people with diabetes in the world has changed.

What are TWO possible reasons for this change? [2 marks]

Tick TWO boxes.

People are becoming more obese

People are doing more exercise

People are eating less salt

People are eating more sugar

People are smoking less

[Turn over]

10



0 4

Chickenpox is a disease. Many children get chickenpox.

Most children recover quickly with no serious long term effects.

Chickenpox cannot be treated with antibiotics.

0 4 . 1

What type of pathogen causes chickenpox? [1 mark]



27

People can pay for their child to be vaccinated against chickenpox.

The vaccination stimulates the production of antibodies.

0 4 . 2 Which part of the blood produces antibodies? [1 mark]

Tick ONE box.

Plasma

Platelets

Red blood cells

White blood cells

[Turn over]



FIGURE 4

**Concentration
of antibodies
in the child's
bloodstream
in arbitrary
units**

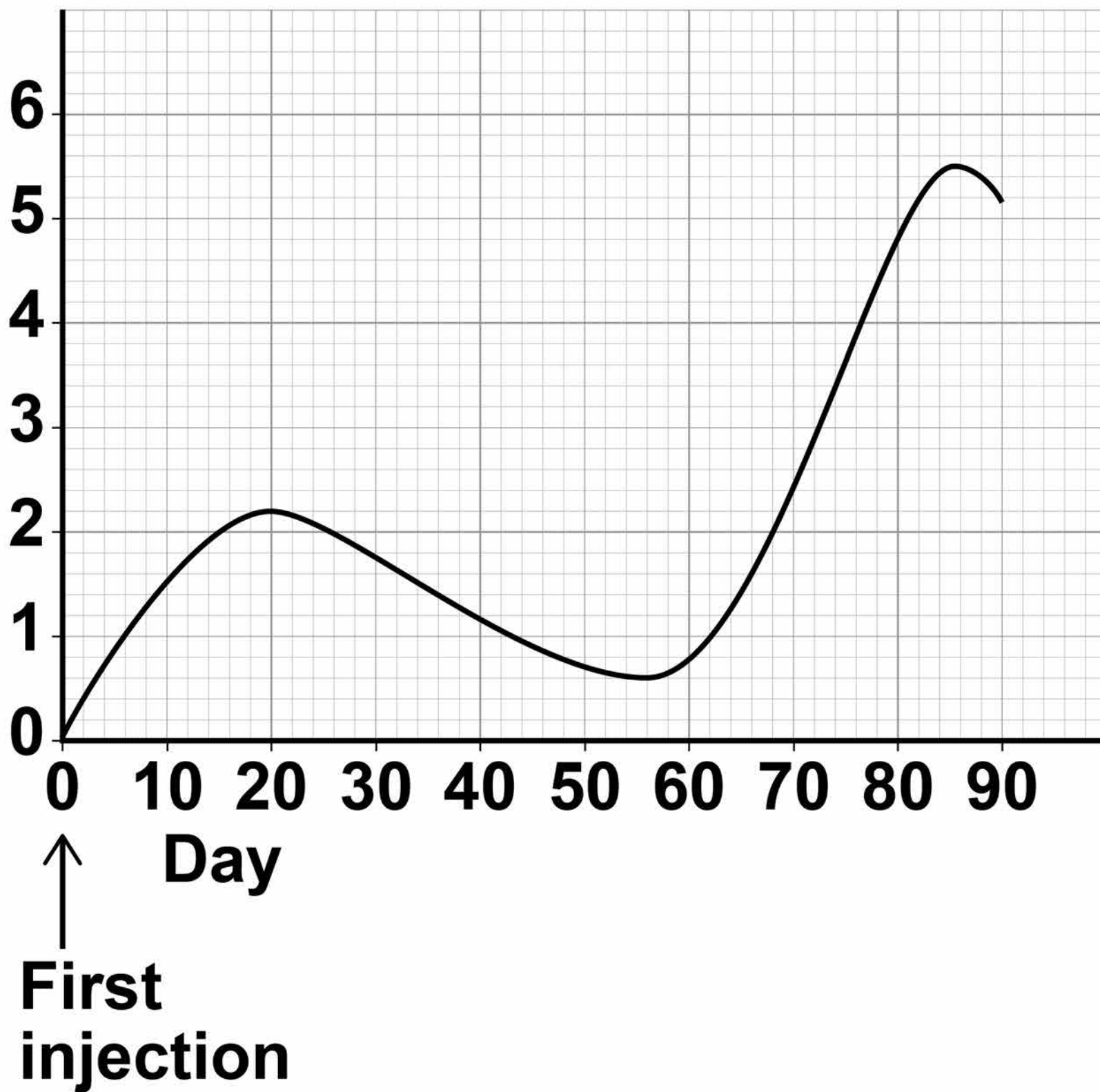

29

The vaccination involves two injections.

FIGURE 4, on page 28, shows how the concentration of antibodies in a child's bloodstream changes.

0 4 . 3 Suggest on what day the second injection was given. [1 mark]

Day = _____

0 4 . 4 On which day is the child's ability to defend against chickenpox at its peak? [1 mark]

Day = _____

[Turn over]



30

Children can only have the chickenpox vaccination if their parents pay for the vaccine.

Some people think the vaccination should be free to all children.

0 4 . 5 **If more people were vaccinated the number of children getting chickenpox would decrease.**

What are TWO possible reasons for the decrease? [2 marks]

Tick TWO boxes on the opposite page.



31

Drugs to treat chickenpox are no longer effective

Children are less likely to come into contact with someone with the disease

More people will have the correct antibodies

People may catch the disease from the vaccination

People may have a weakened immune system

[Turn over]



0 4 . 6 The government needs to decide whether to make the chickenpox vaccination free to all children.

Suggest TWO factors the government should consider when making this decision.

[2 marks]

1

2

8



BLANK PAGE

[Turn over]



0 5

All living organisms are classified into groups.

TABLE 2 shows the classification of one species of wheat.

TABLE 2

Kingdom	Plant
Phylum	Angiosperms
Class	Monocotyledons
Order	Commelinids
Family	Poaceae
Genus	Triticum
Species	spelta



35

0 5 . 1 What is the binomial name for the wheat in TABLE 2, on page 34?
[1 mark]

Tick ONE box.

Angiosperm monocotyledons

Poaceae triticum

Species spelta

Triticum spelta

[Turn over]



BLANK PAGE



Modern classification systems compare the similarity between the DNA of organisms.

The more similar the DNA code, the more closely the organisms are related.

TABLE 3, on page 38, shows DNA codes in five different organisms.

[Turn over]



TABLE 3

DNA Codes										Number of differences in DNA code compared with the human sequence
HUMAN	A	B	C	D	E	F	G	H	I	
Pig	J	F	C	D	E	F	G	H	I	
Wheat	C	I	K	D	M	F	G	H	I	
Yeast	C	I	K	D	L	M	G	H	I	5
Chicken	J	F	C	D	M	F	G	H	I	3



0 5 . 2 Complete the final column of TABLE 3, on page 38, for Pig and for Wheat. [1 mark]

0 5 . 3 Which organism in TABLE 3 appears to be most closely related to humans? [1 mark]

0 5 . 4 Give ONE reason why conclusions about the similarities between organisms should not be made using ONLY the DNA codes in TABLE 3. [1 mark]



[Turn over]



Chickens can be bred either for meat or for laying eggs.

FIGURE 5 gives some information about different types of chicken.

FIGURE 5

	Chicken bred for meat	Chicken bred for laying eggs
		
Average weight in kg	1.8	0.7
Average number of eggs laid per week	2	6





0 5 . 5 Describe how selective breeding has been used to produce chickens bred for meat. [3 marks]

0 5 . 6 Give ONE advantage of selective breeding to the farmer. [1 mark]

[Turn over]



Repeat of FIGURE 5

	Chicken bred for meat	Chicken bred for laying eggs
		
Average weight in kg	1.8	0.7
Average number of eggs laid per week	2	6



05.7 Selective breeding can lead to disadvantages for the chickens.

What is a possible disadvantage of selective breeding for the chickens bred for meat in FIGURE 5, on page 42? [1 mark]

Tick ONE box.

The chickens will be genetically identical

There will be less food to feed people

The chickens may weigh too much to be able to stand

The chickens will be kept in better conditions

[Turn over]



0 6

Two large semi-precious stones are discovered.

A student is asked to find out what material each of the two stones is made of.

The student does this by determining the density of the material of each stone.

FIGURE 6 shows the two stones.

FIGURE 6

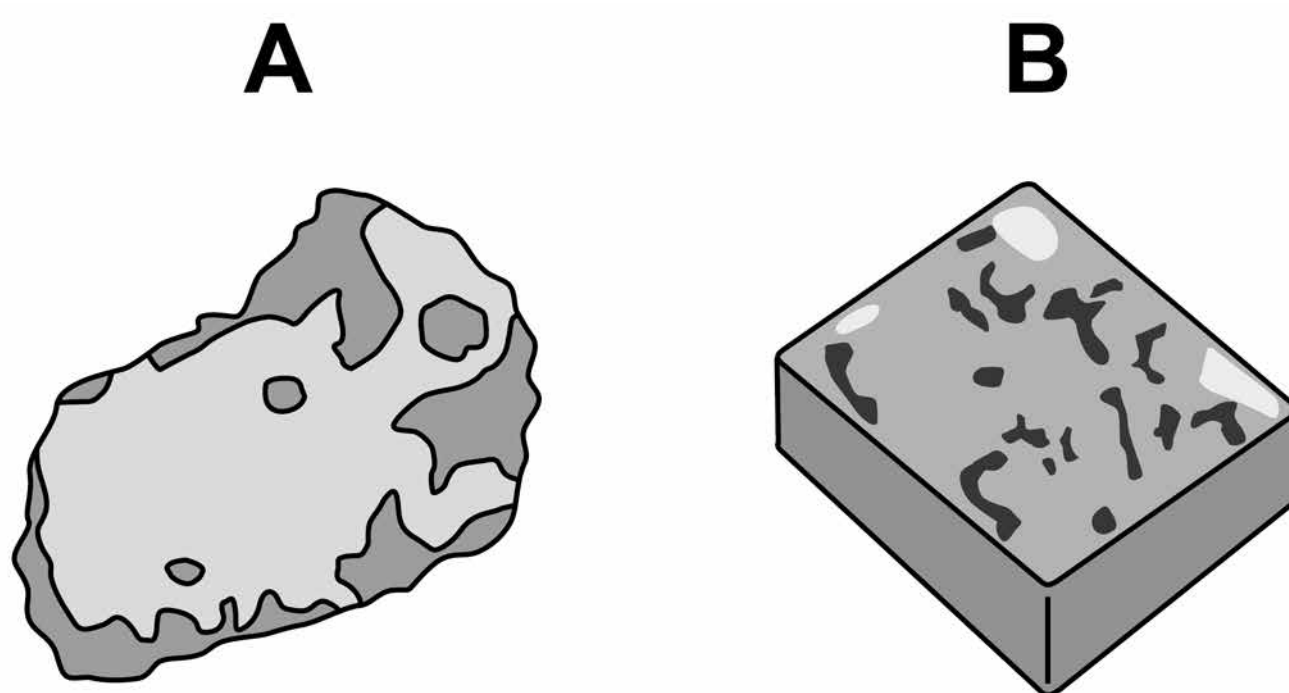

45

06.1 The student wants to measure the volume of stone A. Stone A cannot be measured using a metre rule as the stone is an irregular shape.

Describe how the student could determine the volume of stone A by putting it into water. [3 marks]

[Turn over]



46

The student makes measurements of stone B using a metre rule.

The measurements of stone B are shown in FIGURE 7. It is not drawn accurately.

FIGURE 7

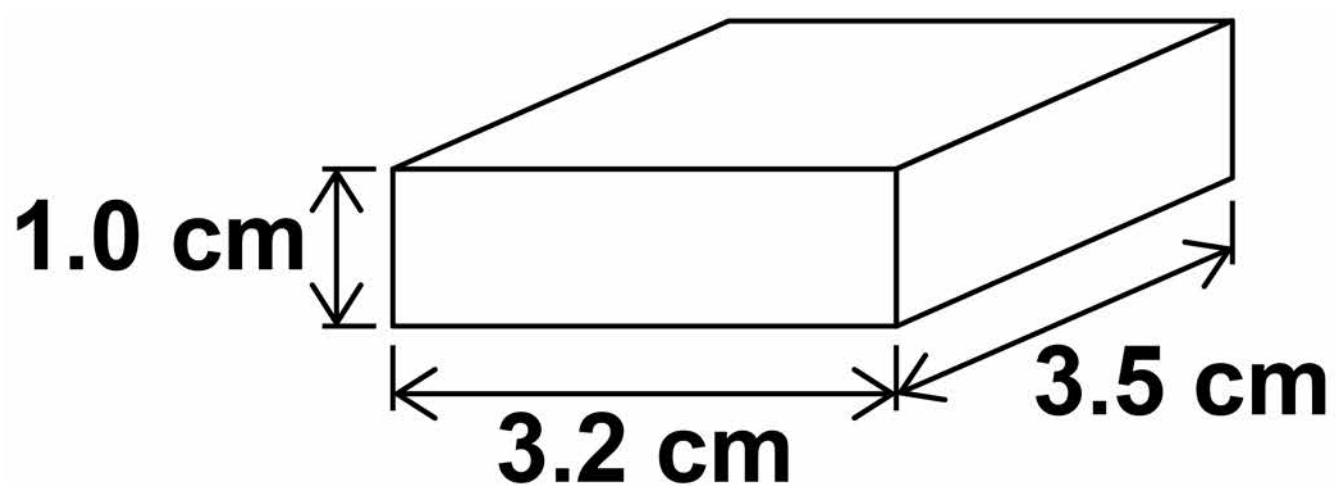

47

06.2 Which piece of equipment could the student use to get a more accurate measurement of the length of stone B? [1 mark]

Tick ONE box.

Electronic balance

Microscope

Newtonmeter

Vernier callipers

[Turn over]



48

06.3 Use the following equation to calculate the volume of stone B in cm^3

volume = length x width x height
[1 mark]

Volume = _____ cm^3



49

06.4 The mass of stone B is 56 grams.

Use your answer from Question 06.3 to calculate the density of stone B in g/cm^3

Use the following equation.

$$\text{density} = \frac{\text{mass}}{\text{volume}}$$

[2 marks]

Density = _____ g/cm^3

[Turn over]



06.5 The student calculates the density of the material stone A is made of as 5.2 g/cm^3

The student looks up the density of some materials in a text book.

FIGURE 8 shows this information.

FIGURE 8

Material	Density in g/cm^3
Amber	1.1 – 1.2
Cubic Zirconia	5.5 – 5.9
Garnet	3.8 – 3.9
Haematite	5.1 – 5.3

51

What material is stone A made of? [1 mark]

Tick ONE box.

Amber

Cubic Zirconia

Garnet

Haematite

[Turn over]

8



0	7
---	---

Osmosis is the movement of water through partially permeable cell membranes.

A group of students investigated the effect of temperature on the rate of osmosis in potato cells. The students used five potato chips all cut to the same size.

FIGURE 9 shows one chip.

FIGURE 9



53

This is the method used.

- 1. Half fill a boiling tube with distilled water.**
- 2. Heat the water to 25 °C**
- 3. Place one potato chip in the boiling tube.**
- 4. Keep the boiling tube and potato chip at 25 °C for 30 minutes.**
- 5. Repeat steps 1–4 at four other temperatures.**

[Turn over]



07.1 All of the potato chips gained water by osmosis.

**Explain how the students would find out the RATE of water uptake by osmosis in each potato chip.
[3 marks]**

07.2 One of the students used a knife to cut the potato chips.

Suggest how the student could improve the method of cutting the potato chips to make sure they are all the same size. [1 mark]

[Turn over]

07.3 Another student cut their potato chips in a 'crinkle cut' style as shown in FIGURE 10.

FIGURE 10

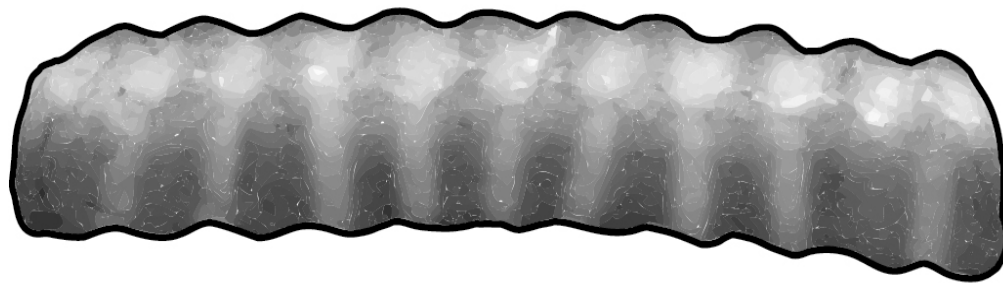

Repeat of FIGURE 9



Suggest how the rate of water uptake by osmosis in this investigation was different from the investigation with the chips shown in FIGURE 9, on page 56.

**Give a reason for your answer.
[2 marks]**

[Turn over]

58

07.4 The students carried out the experiment at 25 °C, 30 °C, 35 °C, 40 °C and 45 °C

Predict what you would expect the results to show as the temperature increases.

**Give a reason for your answer.
[2 marks]**

Prediction _____

Reason _____

8



BLANK PAGE

[Turn over]



60

0 8

Water is important to all living organisms.

In some parts of Africa getting potable water may be difficult.

0 8.1

What is potable water? [1 mark]

Biosand units are one method of purifying water used in some parts of Africa.

FIGURE 11, on page 61, shows a Biosand unit.



FIGURE 11

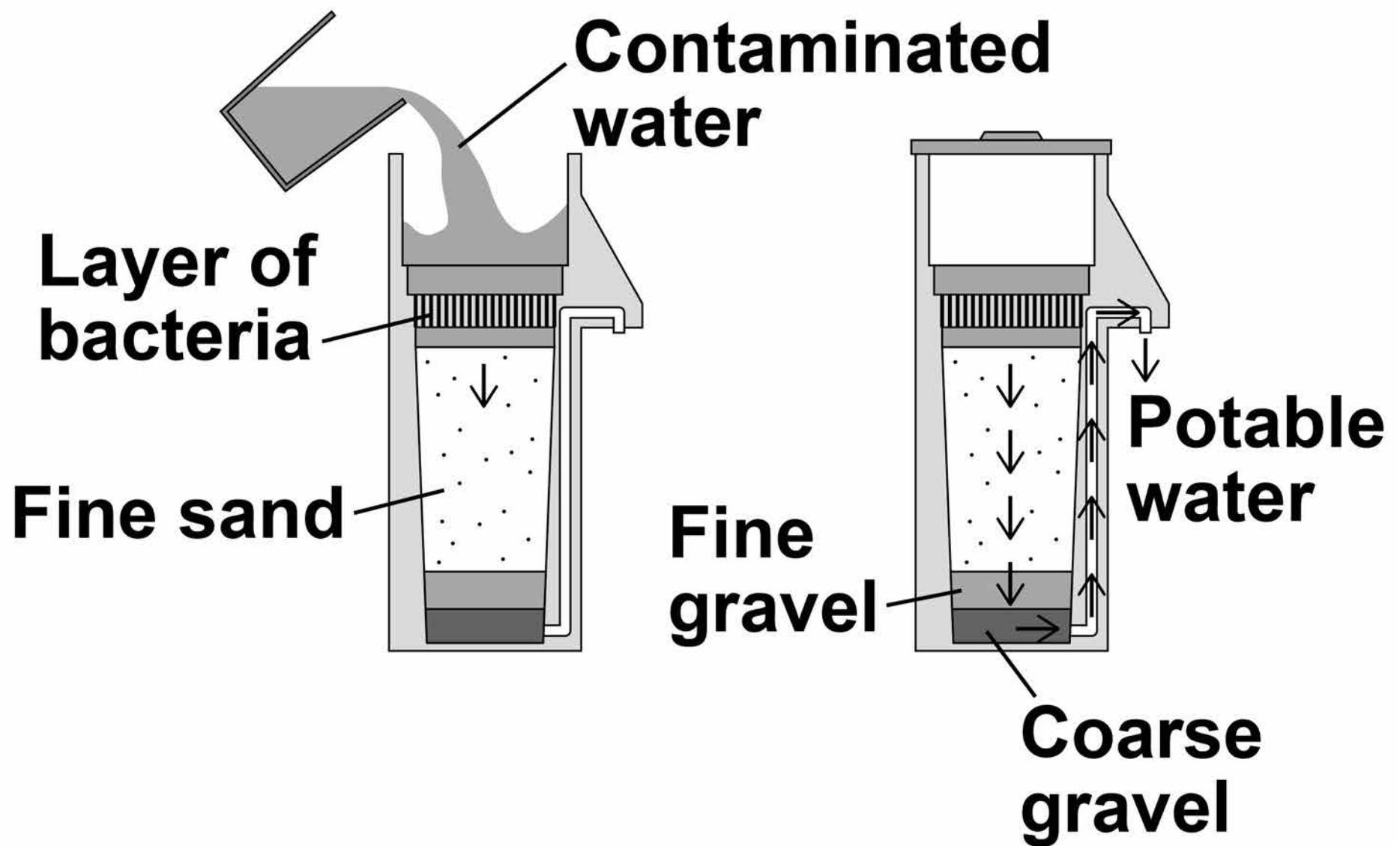

08.2 Describe the role of the fine sand.
[1 mark]

[Turn over]



Another method of purifying water is Solar Disinfection (SODIS).

TABLE 4, on pages 64–65, gives some information about both methods.



BLANK PAGE

[Turn over]



TABLE 4

Method	Description	Percentage reduction in pathogens that cause diarrhoea
Biosand unit	Before use, it needs to be left for 2 weeks for the bacteria in the unit to grow. Can treat 40 litres of water per hour. Made of concrete. Needs replacing every 10 years.	47



Method	Description	Percentage reduction in pathogens that cause diarrhoea
SODIS	<p>Plastic bottles are filled with water and left in sunlight. Ultraviolet (UV) kills bacteria.</p> <p>Bottles need to be left in sunlight for at least 8 hours.</p> <p>Bottles have to be replaced every 6 months.</p>	31

[Turn over]



0 8 . 3

A 1 litre bottle for SODIS costs 29p. Each litre bottle needs replacing after 6 months.

A family uses 6 litres of potable water per day.

Calculate the cost per year of using SODIS for the family. [2 marks]

Cost per year = £ _____



08.4 Other than cost, give TWO disadvantages of using the Biosand unit instead of SODIS.
[2 marks]

1

2

[Turn over]



0 **8** . **5**

Give TWO advantages of using the Biosand unit instead of SODIS. [2 marks]

1

2



0 8 . 6 SODIS uses UV light to sterilise water.

**Give ONE other method of sterilising water.
[1 mark]**

[Turn over]

9



0	9
---	---

A solar water bag can be used to heat water for an outdoor swimming pool.

A student wanted to find out if the colour of the solar water bag affects the temperature increase of the water inside the bag.

FIGURE 12, on page 72, shows some of the equipment used.



71

BLANK PAGE

[Turn over]

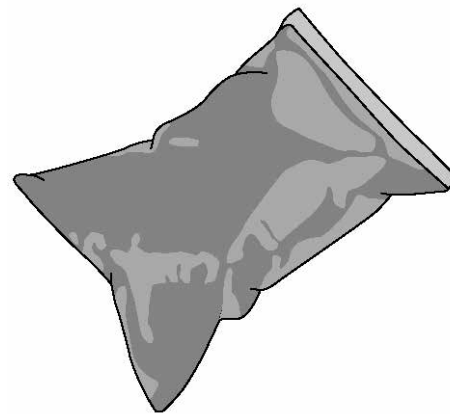
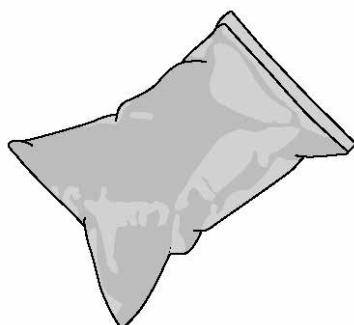
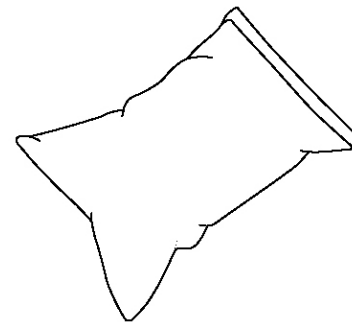

FIGURE 12**Black bag****Pale blue bag****Pale green bag****White bag**

This is the method used.

- 1. Fill each bag with water.**
- 2. Place the four bags on the ground outside.**
- 3. After three hours, measure the temperature of the water inside each bag.**
- 4. Repeat steps 1–3 on the next two days.**



09.1 Suggest **THREE** changes the student should make to this method to get valid results.
[3 marks]

1 _____

2 _____

3 _____

[Turn over]



74

The student repeated the investigation using an improved method.

The results obtained were valid.

TABLE 5 shows the results.

TABLE 5

Colour of bag	Temperature increase in °C			
	Day 1	Day 2	Day 3	Mean
Black	44.0	31.4	43.4	39.6
Pale blue	38.5	23.6	38.1	33.4
Pale green	37.9	23.7	37.7	33.1
White	25.3	23.4	24.2	X



75

09.2 The student used a thermometer to measure the temperature of the water inside each bag.

What was the resolution of the thermometer? [1 mark]

Resolution = _____ °C

09.3 Suggest ONE reason why the temperatures increased less on Day 2 than on Day 1 and Day 3. [1 mark]

[Turn over]



Repeat of TABLE 5

Colour of bag	Temperature increase in °C			
	Day 1	Day 2	Day 3	Mean
Black	44.0	31.4	43.4	39.6
Pale blue	38.5	23.6	38.1	33.4
Pale green	37.9	23.7	37.7	33.1
White	25.3	23.4	24.2	X

0 9 . 4 Calculate the mean temperature increase for the white bag.
[1 mark]

Mean temperature increase =
_____ °C



09.5 Which colour of bag would be best to use to heat water?

**Give a reason for your answer.
[2 marks]**

Colour _____

Reason _____

[Turn over]

8



BLANK PAGE



79

1 0

Dravet syndrome is caused by a genetic mutation.

Dravet syndrome causes epileptic seizures. An epileptic seizure is caused by unusual brain activity.

1 0 . 1

Mutations often happen when cells divide.

Give ONE other cause of genetic mutations. [1 mark]

[Turn over]



80

1 0 . 2 Scientists have transferred the mutated gene for Dravet syndrome into zebrafish using genetic engineering.

This means the scientists could test a new drug to treat Dravet syndrome on the zebrafish.

Which TWO of the following are used during the process of genetic engineering? [2 marks]

Tick TWO boxes on the opposite page.



81

Enzymes

Placebos

Vaccines

Vectors

White blood cells

[Turn over]



10.3 Scientists used the genetically engineered zebrafish to test the new drug.

Describe the processes that then need to happen to test the new drug before it can be used to treat all children with Dravet syndrome. [6 marks]

[Turn over]

9



1 1

A man with breathing difficulties goes to hospital.

FIGURE 13 shows his lung scan and chest X-ray.

FIGURE 13



Lung scan

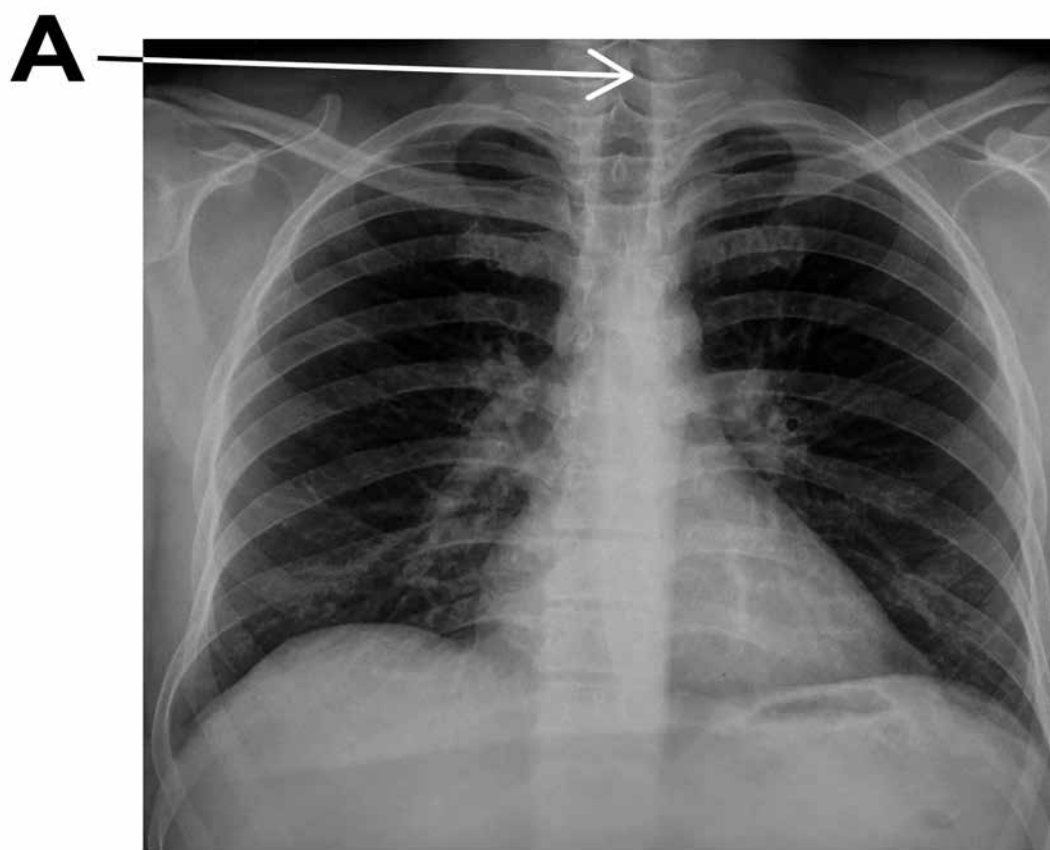

Chest X-ray

1 1 . 1 What is part A? [1 mark]

Tick ONE box.

Bronchus

Capillary

Trachea

Vein

[Turn over]



1 1 . 2 Give ONE advantage of using the **LUNG SCAN**, rather than the chest X-ray, to diagnose problems with the man's breathing system. [1 mark]

1 1 . 3 Give ONE advantage of using the **CHEST X-RAY**, rather than the lung scan, to diagnose problems with the man's breathing system. [1 mark]



11.4 Aerobic respiration and anaerobic respiration are the two types of cell respiration.

Give THREE differences between aerobic and anaerobic respiration. [3 marks]

1 _____

2 _____

3 _____

[Turn over]



1 1 . 5 A health website contains the following advice:

Stop smoking and you will be healthier and live longer.

Explain why stopping smoking will improve a person's health. [6 marks]

END OF QUESTIONS

12



There are no questions printed on this page

For Examiner's Use	
Question	Mark
1	
2	
3	
4	
5	
6	
7	
8	
9	
10	
11	
TOTAL	

Copyright information

For confidentiality purposes, from the November 2015 examination series, acknowledgements of third party copyright material will be published in a separate booklet rather than including them on the examination paper or support materials. This booklet is published after each examination series and is available for free download from www.aqa.org.uk after the live examination series.

Permission to reproduce all copyright material has been applied for. In some cases, efforts to contact copyright-holders may have been unsuccessful and AQA will be happy to rectify any omissions of acknowledgements. If you have any queries please contact the Copyright Team, AQA, Stag Hill House, Guildford, GU2 7XJ.

Copyright © 2018 AQA and its licensors. All rights reserved.

IB/M/Jun18/NC/8465/2F/E3

