



**Surname** \_\_\_\_\_

**Other Names** \_\_\_\_\_

**Centre Number** \_\_\_\_\_

**Candidate Number** \_\_\_\_\_

**Candidate Signature** \_\_\_\_\_

**GCSE**

**MATHEMATICS**

**H**

**Higher Tier Paper 3 Calculator**

**8300/3H**

**Tuesday 12 June 2018 Morning**

**Time allowed: 1 hour 30 minutes**

**At the top of the page, write your surname and other names, your centre number, your candidate number and add your signature.**

**[Turn over]**



**For this paper you must have:**

- **a calculator**
- **mathematical instruments.**

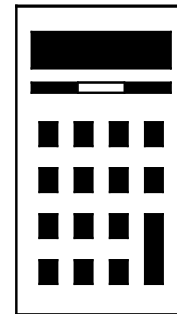

## **INSTRUCTIONS**

- **Use black ink or black ball-point pen. Draw diagrams in pencil.**
- **Answer ALL questions.**
- **You must answer the questions in the spaces provided. Do not write on blank pages.**
- **Do all rough work in this book. Cross through any work you do not want to be marked.**



## **INFORMATION**

- **The marks for questions are shown in brackets.**
- **The maximum mark for this paper is 80.**
- **You may ask for more answer paper, graph paper and tracing paper. These must be tagged securely to this answer book.**

## **ADVICE**

- **In all calculations, show clearly how you work out your answer.**

**DO NOT TURN OVER UNTIL TOLD TO DO SO**



4

**Answer ALL questions in the spaces provided**

- 1 Circle the decimal that is closest in value to  $\frac{11}{20}$  [1 mark]**

0.56

0.6

0.525

0.5

- 2 Circle the list of ALL the integers that satisfy  $-2 < x \leq 4$  [1 mark]**

- 2, - 1, 0, 1, 2, 3

- 1, 0, 1, 2, 3

- 2, - 1, 0, 1, 2, 3, 4

- 1, 0, 1, 2, 3, 4



5

**3 Circle the largest number. [1 mark]**

**3.2 $\dot{7}$       3.27      3.277      3.20 $\dot{7}$**

**4 What is the size of an exterior angle of a regular decagon?**

**Circle your answer. [1 mark]**

**18°      36°      144°      162°**

**[Turn over]**



# 6

**5**  $a$  is a common factor of 72 and 120

$b$  is a common multiple of 6 and 9

**Work out the highest possible value**

**of  $\frac{a}{b}$**

**[4 marks]**

---

---

---

---

---

---

---

---

---

---

---

---

---

---

---

---

---

---

---

---

---

---

---

---

**Answer** \_\_\_\_\_



7

**BLANK PAGE**

**[Turn over]**



8

- 6 A and B are similar shapes.  
B is an enlargement of A with scale factor 1.5

The diagram is not drawn accurately.

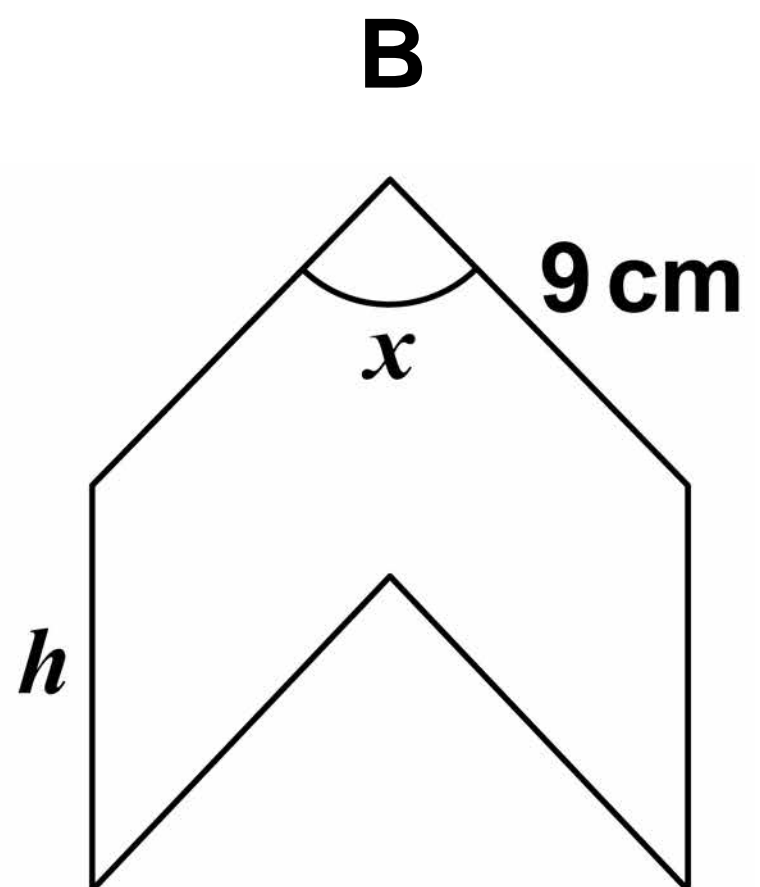
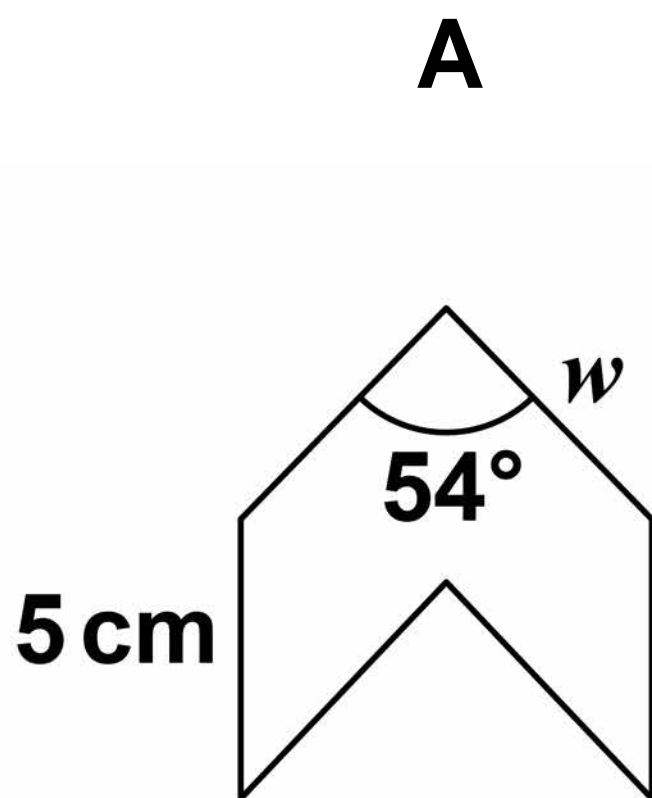



9

Work out the values of  $x$ ,  $h$  and  $w$ .  
[3 marks]

---

---

---

---

---

---

---

---

---

---

---

---

---

---

---

---

$x =$  \_\_\_\_\_ **degrees**

$h =$  \_\_\_\_\_ **cm**

$w =$  \_\_\_\_\_ **cm**

[Turn over]



**7 Investment A**

**Save £150 per month for 2 years.  
2.5% interest is added to the total  
amount saved.**

**Investment B**

**Invest £3500**

**Compound interest is added at 3% per  
year.**

**After 2 years, how much MORE is  
investment B worth than  
investment A? [4 marks]**

---

---

---

---

---

---

---

---

---

---



---

---

**Answer**    **£**

---

<hr/>
<b>7</b>

**[Turn over]**



8(a) Show that the lines  $y = 3x + 7$  and  $2y - 6x = 8$  are parallel.

**Do NOT use a graphical method.**

**[3 marks]**

---

---

---

---

---

---

---

---

---

---

---

---

---

---

---

---

---

---

---

---

---



13

**8(b) Is the point  $(-5, -6)$  above, below or on the line  $y = 3x + 7$  ?**

**Tick ONE box.**

**Above****Below****On the line**

**You MUST show your working.  
Do NOT use a graphical method.  
[2 marks]**

---

---

---

---

---

---

---

---

---

---

---

---

---

---

---

---

---

---

---

---

---

---

---

---

**[Turn over]**



**9 The cost of a ticket increases by 10% to £19.25**

**Work out the original cost.  
[3 marks]**

---

---

---

---

---

**Answer £** \_\_\_\_\_



15

**10** The  $n$ th term of a sequence is

$$12n - 5$$

**Work out the numbers in the sequence that have two digits and are NOT prime. [3 marks]**

---

---

---

---

---

---

---

---

---

---

---

---

---

---

---

**Answer** \_\_\_\_\_

**[Turn over]**



16

$$11 \quad a = \begin{pmatrix} 6 \\ -10 \end{pmatrix} \quad b = \begin{pmatrix} -1 \\ 2 \end{pmatrix} \quad c = \begin{pmatrix} -4 \\ 7 \end{pmatrix}$$

11 (a) Work out  $a + b + c$  [2 marks]

---

---

---

---

---

---

---

Answer  $\left( \quad \right)$





**11 (b) Show that  $a + 2c$  is parallel to  $b$   
[2 marks]**

---

---

---

---

---

---

---

---

---

---

**[Turn over]**



18

$$12 \quad \text{pressure} = \frac{\text{force}}{\text{area}}$$

**A force of 40 Newtons is applied to an area of 3.2 square metres.**

**Work out the pressure.**

**Give the units of your answer.  
[2 marks]**

---

---

---

---

**Answer** \_\_\_\_\_



**13 Tick ALL the statements that are true for any rhombus. [1 mark]**

**The diagonals are lines of symmetry**

**The diagonals bisect each other**

**The diagonals are perpendicular**

**The diagonals are equal in length**

**[Turn over]**

7



20

- 14 Draw the graph, on the opposite page, of  $y = 0.8^x$  for values of  $x$  from 0 to 6 [3 marks]

$x$	0	1	2	3	4	5	6
$y$							



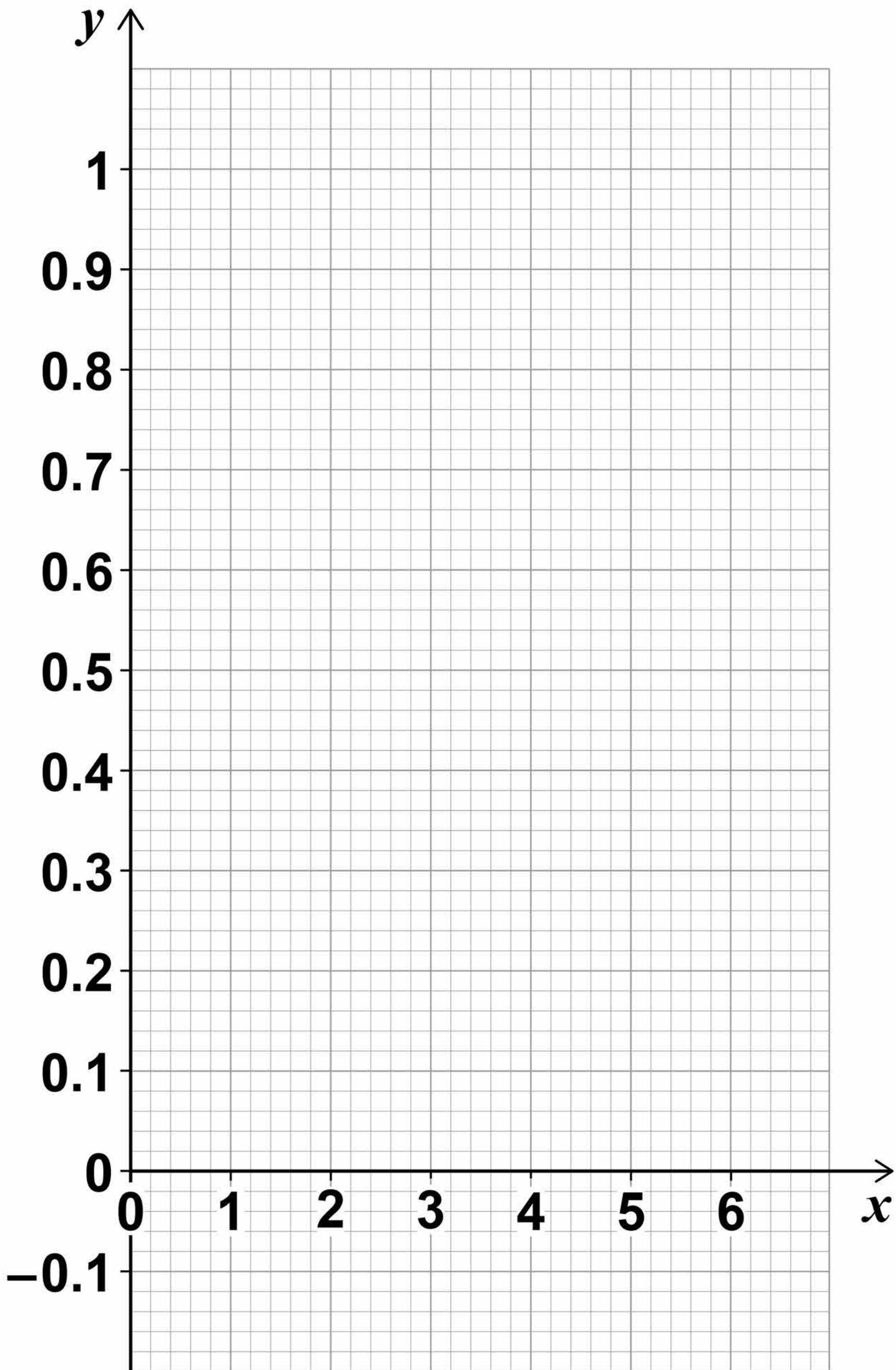

**[Turn over]**



**15 Amy has  $x$  beads.**

**Billy has three more beads than Amy.**

**Carly has four times as many beads as Billy.**

**Circle the expression for the number of beads that Carly has.  
[1 mark]**

$$4x + 3$$

$$3x + 4$$

$$4(x + 3)$$

$$x + 12$$



**16 Two straight lines intersect at point A.**

**The diagram is not drawn accurately.**

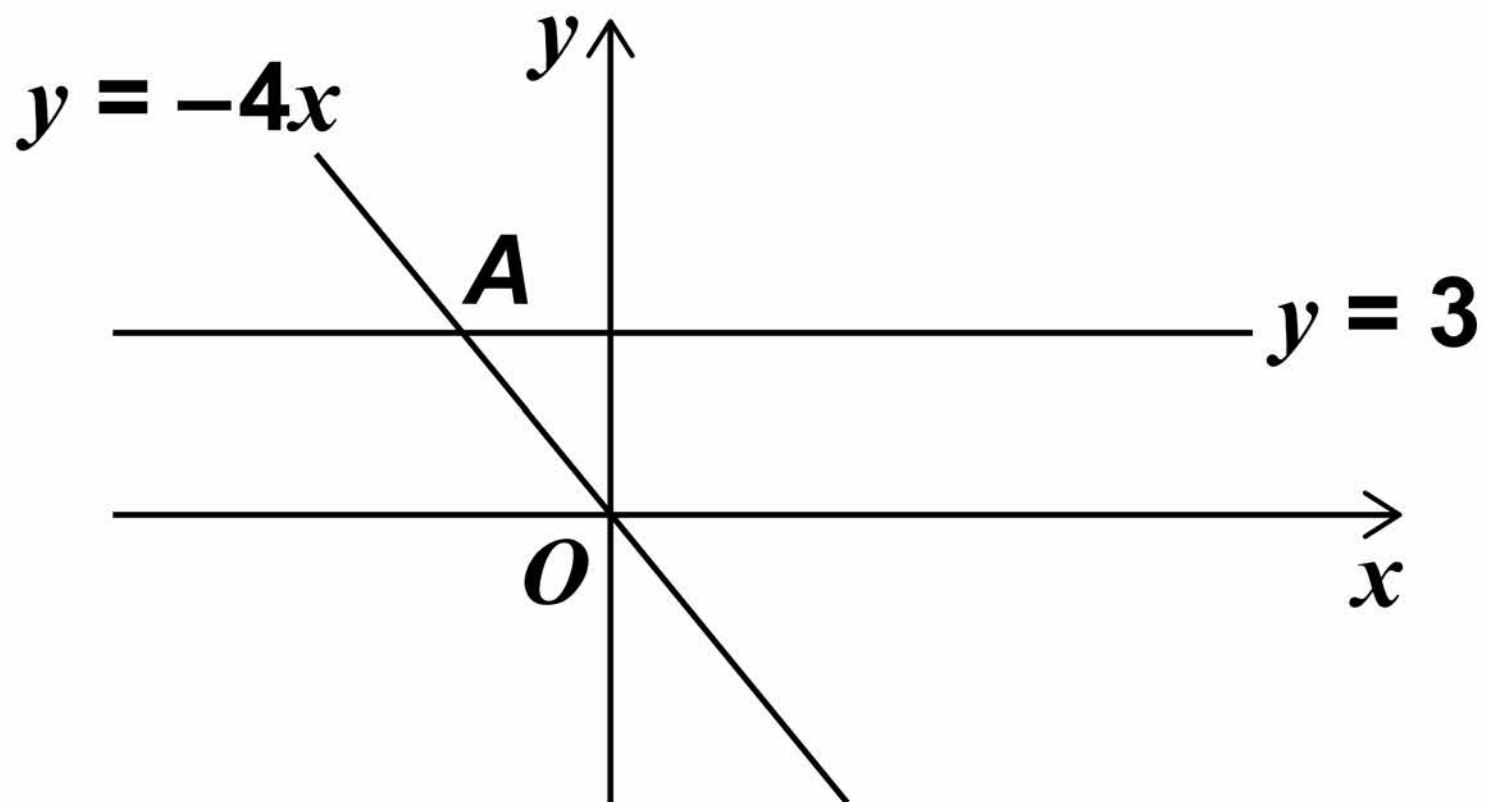

**Circle the coordinates of A. [1 mark]**

$$\left(-\frac{3}{4}, 3\right)$$

$$(-4, 3)$$

$$(-12, 3)$$

$$\left(-\frac{4}{3}, 3\right)$$

**[Turn over]**



**17 Here are two methods to make a 4-digit code.**

**Codes can have repeated digits.**

### **METHOD A**

**For the first two digits use an odd number between 30 and 100**

**For the last two digits use a multiple of 11**

### **METHOD B**

**Use four digits in the order  
even odd even odd**

**Do NOT use the digit zero**

**Which method gives the GREATER number of possible codes?**

**You MUST show your working.  
[3 marks]**





25

---

---

---

---

---

---

---

---

---

---

---

---

---

---

---

---

---

---

---

---

---

---

---

---

---

**Answer** \_\_\_\_\_

**[Turn over]**



18 Show that, for  $x \neq 0$

$$\frac{x + 4}{3x} - \frac{5}{2x}$$

can be written in the form  $\frac{ax + b}{cx}$

where  $a$ ,  $b$  and  $c$  are integers.  
[3 marks]

---

---

---

---

---

---

---

---

---

---

---

---

---

---

---

---

---

---

---

---

---

---

---

---

---

---

---

**Answer** \_\_\_\_\_

**19** The equation of a straight line is  
 $3x + 2y = 24$

**Circle the point where the line  
crosses the  $x$ -axis. [1 mark]**

**(0, 8)**

**(12, 0)**

**(0, 12)**

**(8, 0)**

**[Turn over]**

<hr/>
<b>7</b>



20 All dimensions are in centimetres.

The diagram is not drawn accurately.

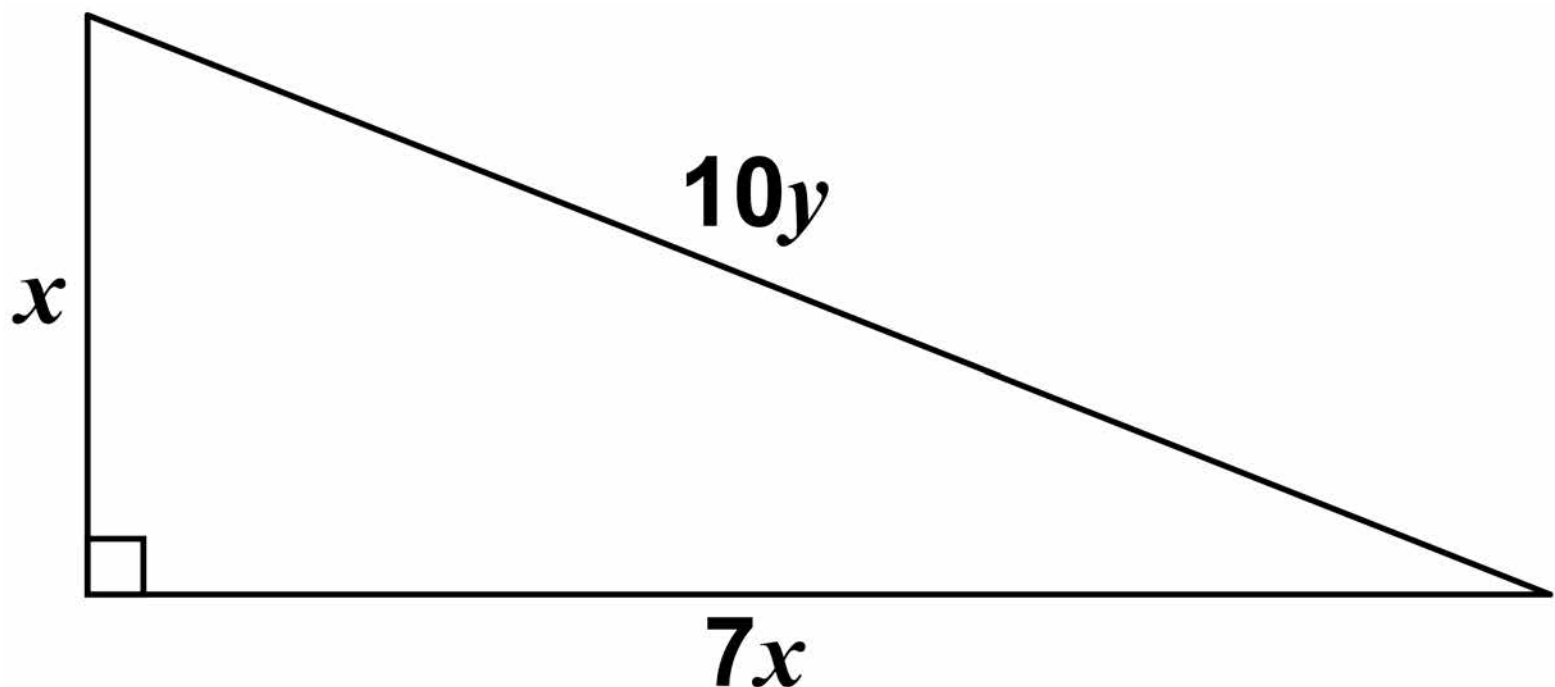

Use Pythagoras' theorem to work out the exact value of  $\frac{x}{y}$  [3 marks]

---

---

---

---

---

---

---

---

---

---

---

---

---

---

---

---

---

---

**Answer** \_\_\_\_\_

**[Turn over]**



**21** The mass of an ornament is  $m$  grams.

The height of the ornament is  $h$  centimetres.

$m$  is directly proportional to the cube of  $h$ .

$m = 1600$  when  $h = 8$

**21 (a)** Work out an equation connecting  $m$  and  $h$ . [3 marks]

---

---

---

---

---

---

---

---

---

---

---

---

**Answer** \_\_\_\_\_



31

**21 (b) Work out the mass of an ornament of height 12 centimetres. [2 marks]**

---

---

---

---

---

---

---

---

**Answer** \_\_\_\_\_ **grams**

8

**[Turn over]**



- 22 ***A, B and C are points on a circle.  $DCB$  is a straight line.  $PAQ$  is a tangent to the circle. The diagram is not drawn accurately.***

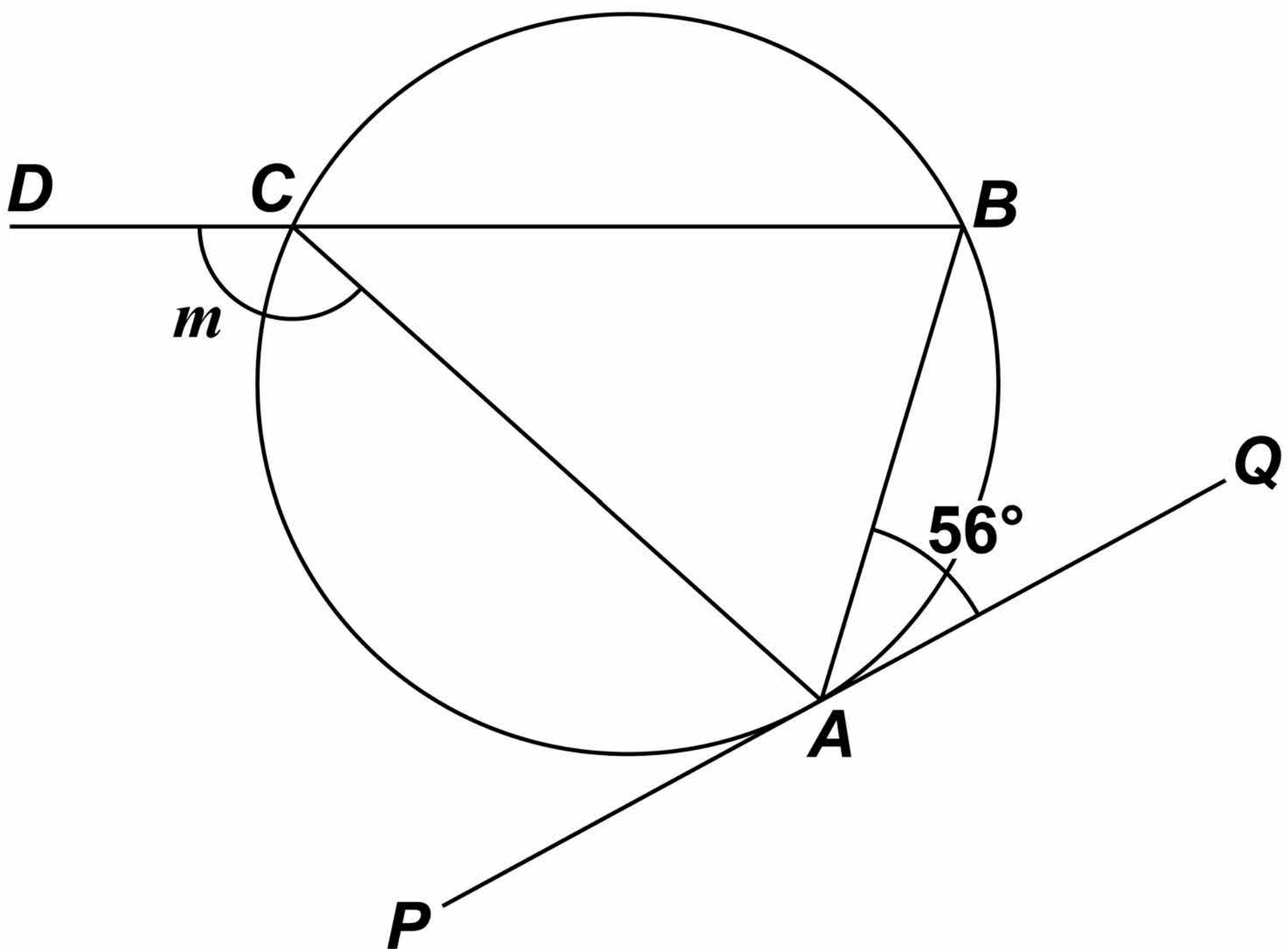



33

Sam is trying to work out the size of angle  $m$ .

Here is his working.

angle  $ACB = 56^\circ$

angles in the same segment are equal

$$m = 180^\circ - 56^\circ$$

angles at a point on a straight line add up to  $180^\circ$

$$m = 124^\circ$$

Make a criticism of his working.  
[1 mark]

---

---

---

---

[Turn over]



# BLANK PAGE



23 A sequence of numbers is formed by the iterative process

$$u_{n+1} = \frac{3}{u_n + 1}, \quad u_1 = 4$$

Work out the values of  $u_2$  and  $u_3$   
[2 marks]

---

---

---

---

---

$$u_2 =$$

---

$$u_3 =$$

---

3
---

[Turn over]



**24** The speed-time graph shows 20 seconds of a car journey. Harry wants to estimate the distance the car travels in this time.

He uses a triangle and a trapezium, as shown, to estimate the area under the graph.

### Car journey

Speed  
(m/s)

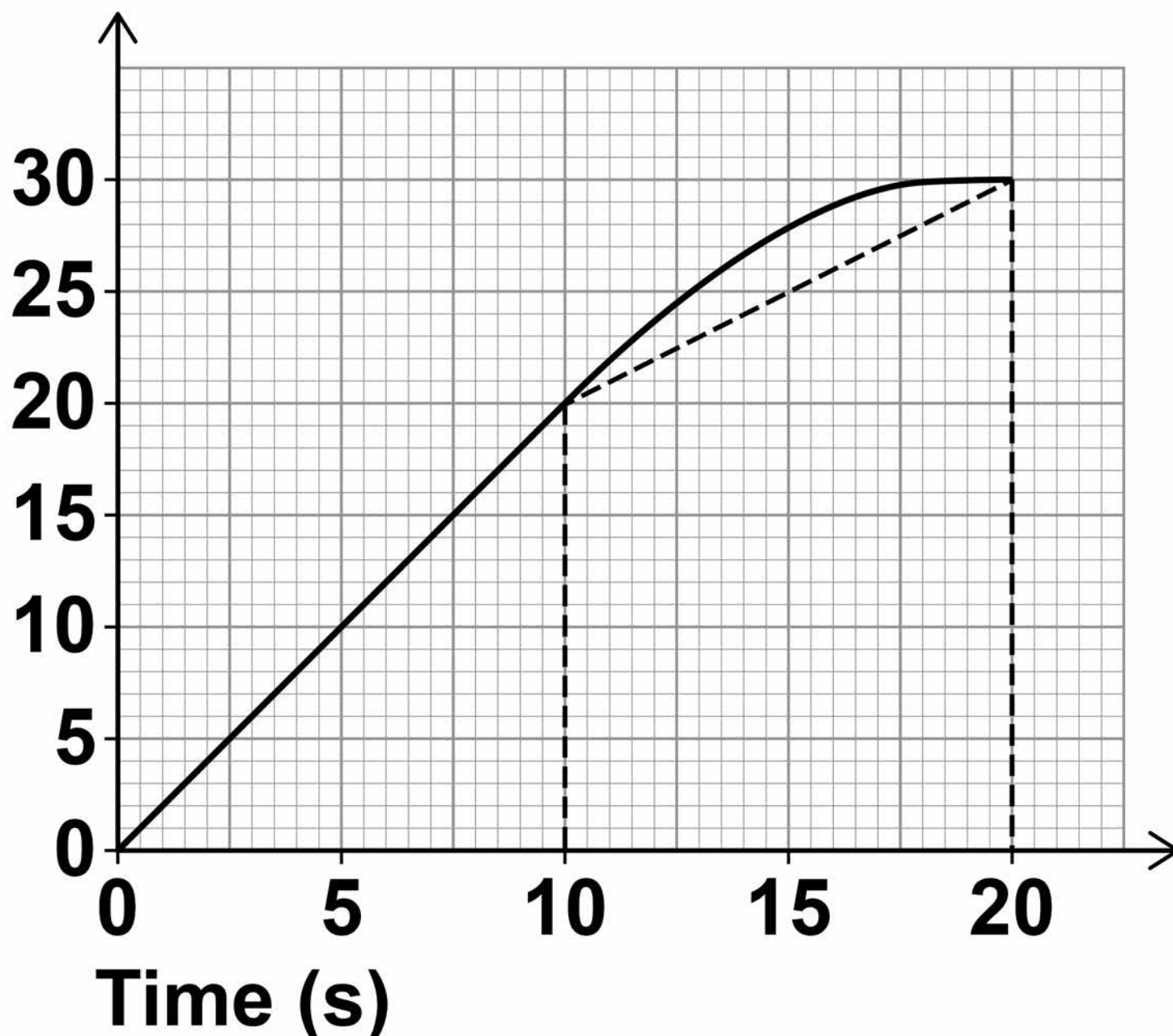

**24 (a) Complete Harry’s method to estimate the distance the car travels. [3 marks]**

---

---

---

---

---

---

---

---

---

---

---

---

---

---

---

---

---

---

---

---

---

---

---

**Answer** \_\_\_\_\_ **m**

**[Turn over]**



# BLANK PAGE



**24 (b) For this journey, which of these is true for Harry's method?**

**Tick ONE box. [1 mark]**

**It works out an overestimate of the distance**

**It works out an underestimate of the distance**

**It could work out an overestimate or an underestimate of the distance**

**[Turn over]**

4



40

25 *ABCDEF* is a triangular prism which represents part of a hill.

*ABCF* is the horizontal rectangular base.

*D* is vertically above *C*

*BC* = 500 m

*AB* = 400 m

Angle *DBC* =  $6^\circ$

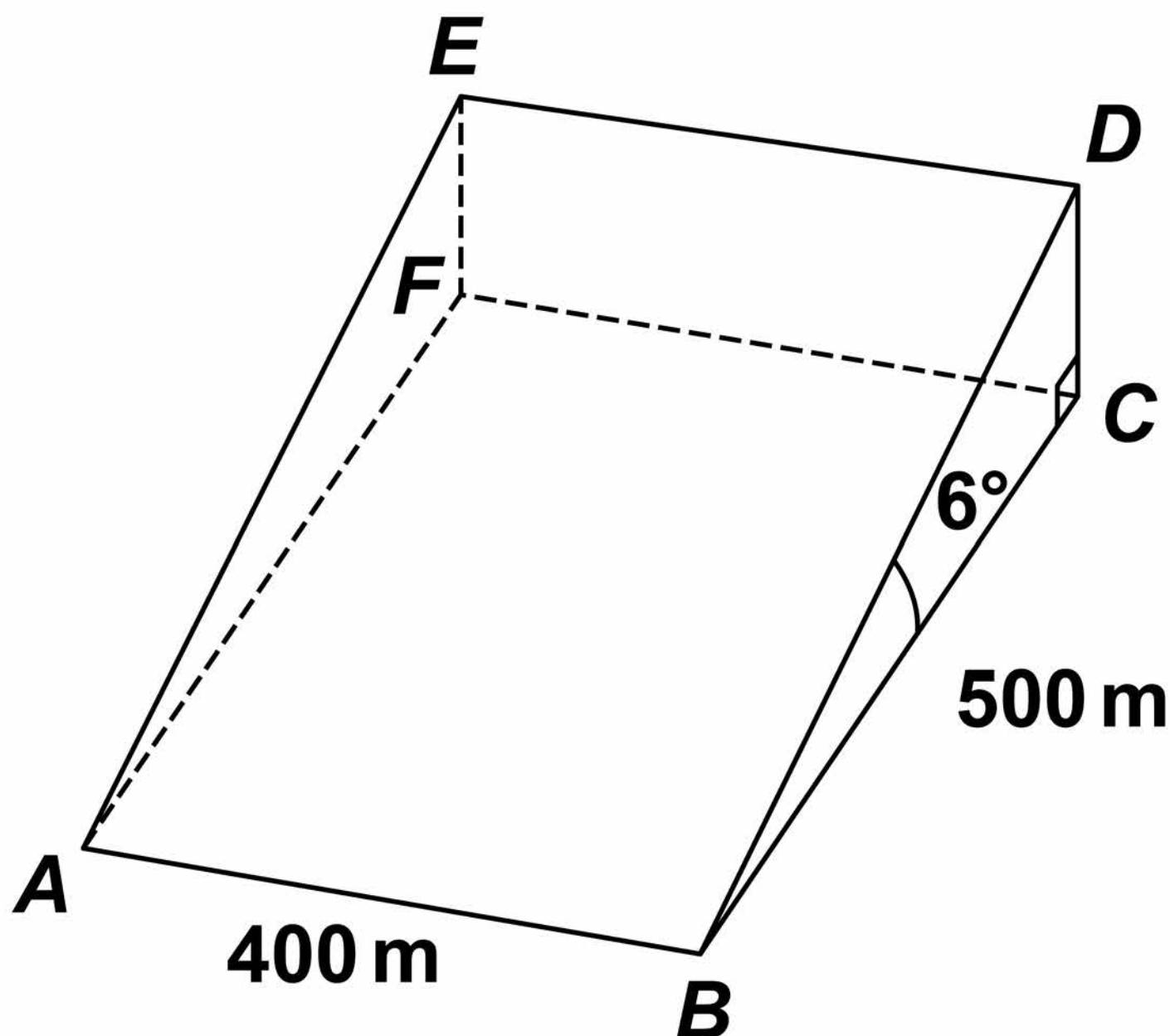



41

Diagram i. The diagram below shows the triangle  $BCD$ .

It is not drawn to scale.

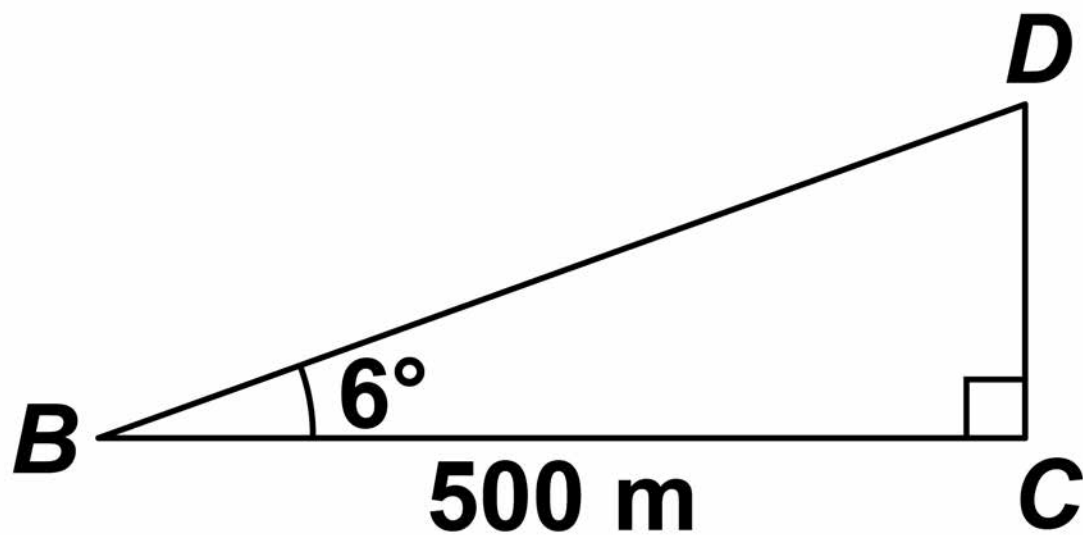

**25 (a) Work out the height  $CD$ .**  
**[2 marks]**

---

---

---

---

**Answer** \_\_\_\_\_ **m**

**[Turn over]**



42

25 (b) Jamil walks in a straight line from  $A$  to  $D$ .

Diagram ii. The diagram shows a plan view of the base of the triangular prism.

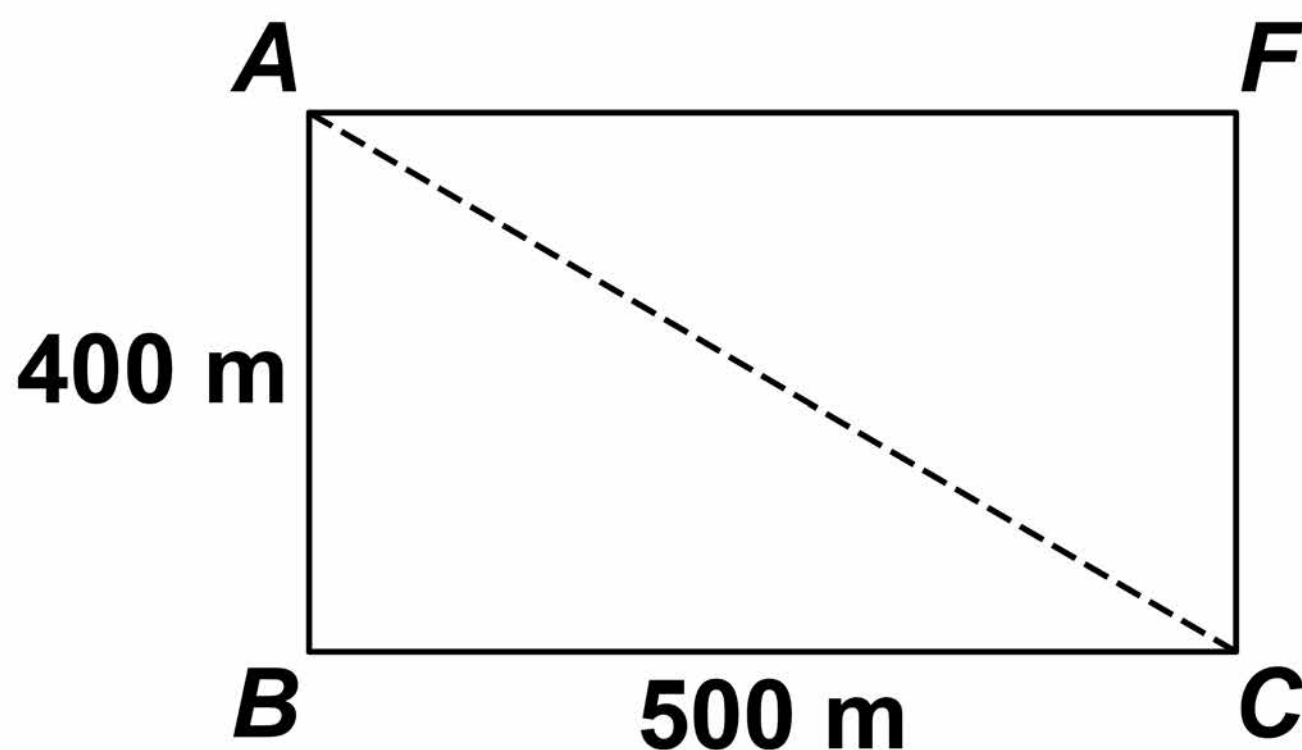
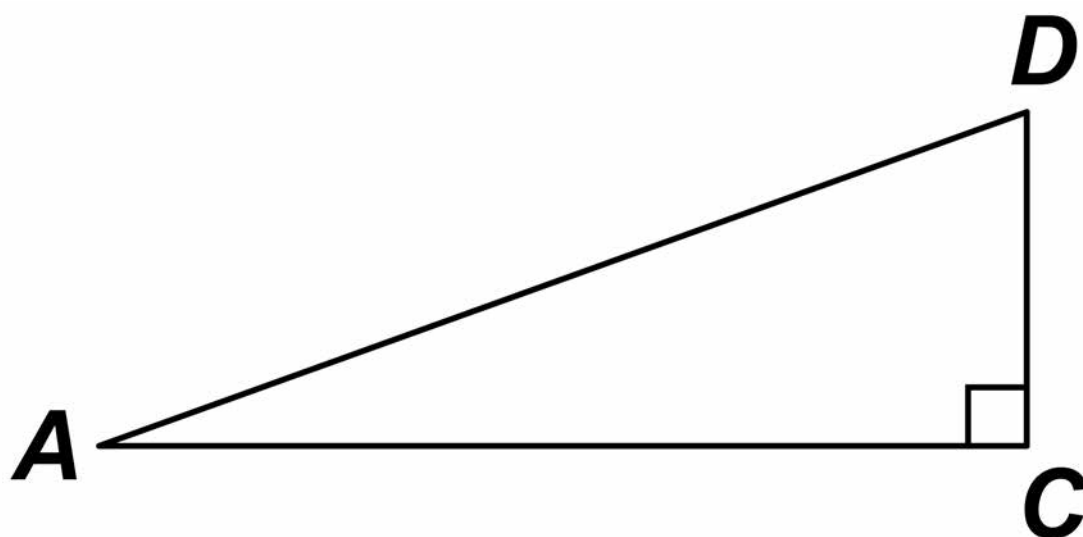

Diagram iii. The diagram below shows the triangle  $DAC$ .

It is not drawn to scale.



43

**Work out the size of angle  $DAC$ .  
You MUST show your working.  
[4 marks]**

---

---

---

---

---

---

---

---

---

---

---

---

---

---

---

---

---

---

---

---

---

---

---

---

**Answer \_\_\_\_\_ degrees**

**[Turn over]**

6



- 26 The histogram shows information about the speed of cars as they pass a checkpoint. The scale on the frequency density axis is missing.

Speed of cars

Frequency density

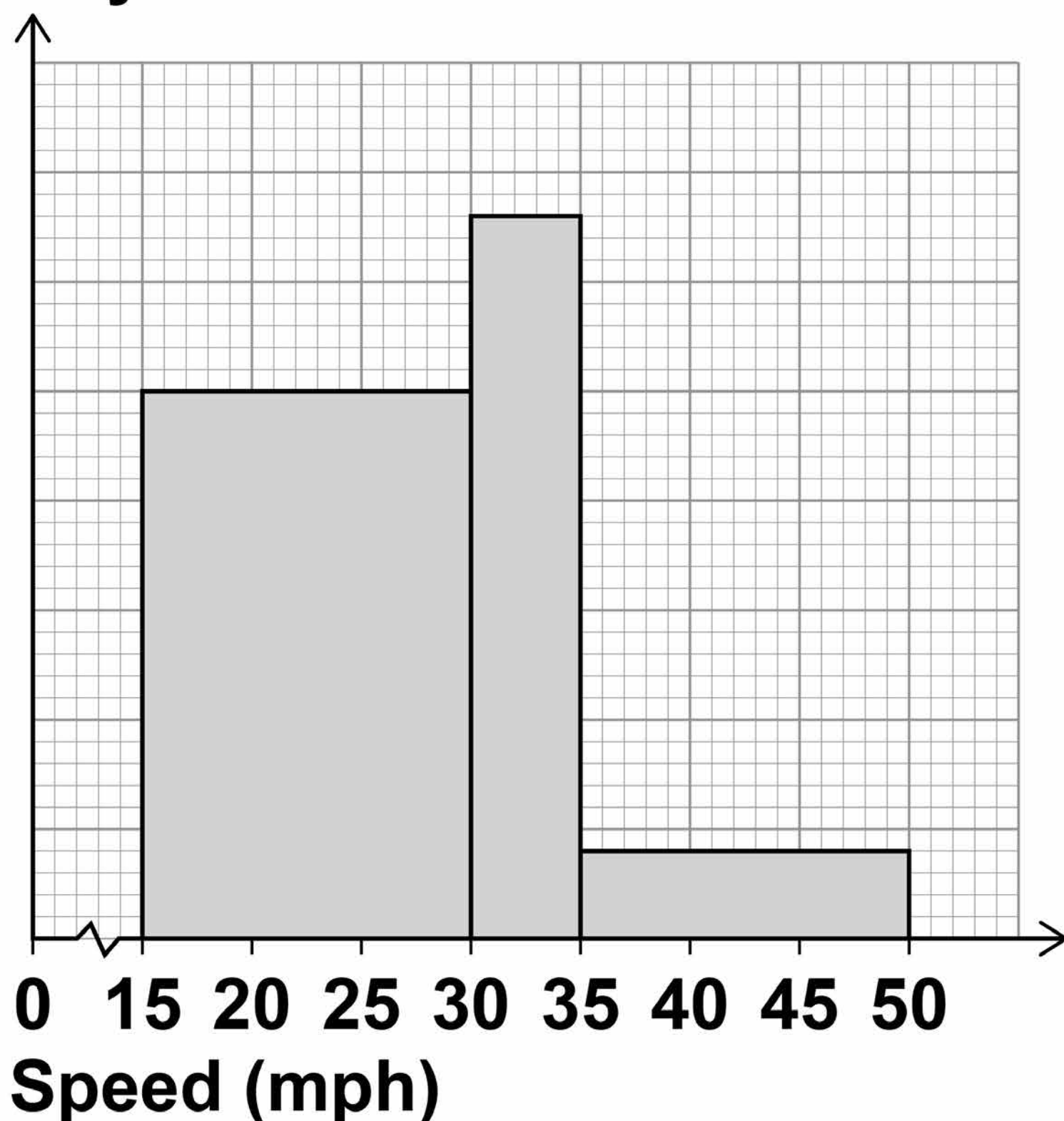

45

The histogram shows information about 480 cars.

26 (a) How many cars does the first bar represent? [4 marks]

---

---

---

---

---

---

---

---

---

---

---

---

Answer \_\_\_\_\_

[Turn over]

# BLANK PAGE



**26 (b) Cars with a speed greater than 40 mph are over the speed limit.**

**Use the histogram to estimate the number of cars that are over the speed limit. [2 marks]**

---

---

---

---

---

---

---

---

---

---

---

**Answer** \_\_\_\_\_

**[Turn over]**

6



48

27

**A bag contains 30 discs.**

**10 are red and 20 are blue.**

**One disc is taken out at random and replaced by TWO of the other colour.**

**Another disc is then taken out at random and replaced by TWO of the other colour.**

**Another disc is then taken out at random.**

**Work out the probability that all three discs taken out are RED.**

**[3 marks]**

---

---

---

---

---

---

---

---





49

---

---

---

**Answer** \_\_\_\_\_

**[Turn over]**



50

28

$P$  is a point on the circle with equation  $x^2 + y^2 = 80$

$P$  has  $x$ -coordinate 4 and is below the  $x$ -axis.

The diagram is not drawn accurately.

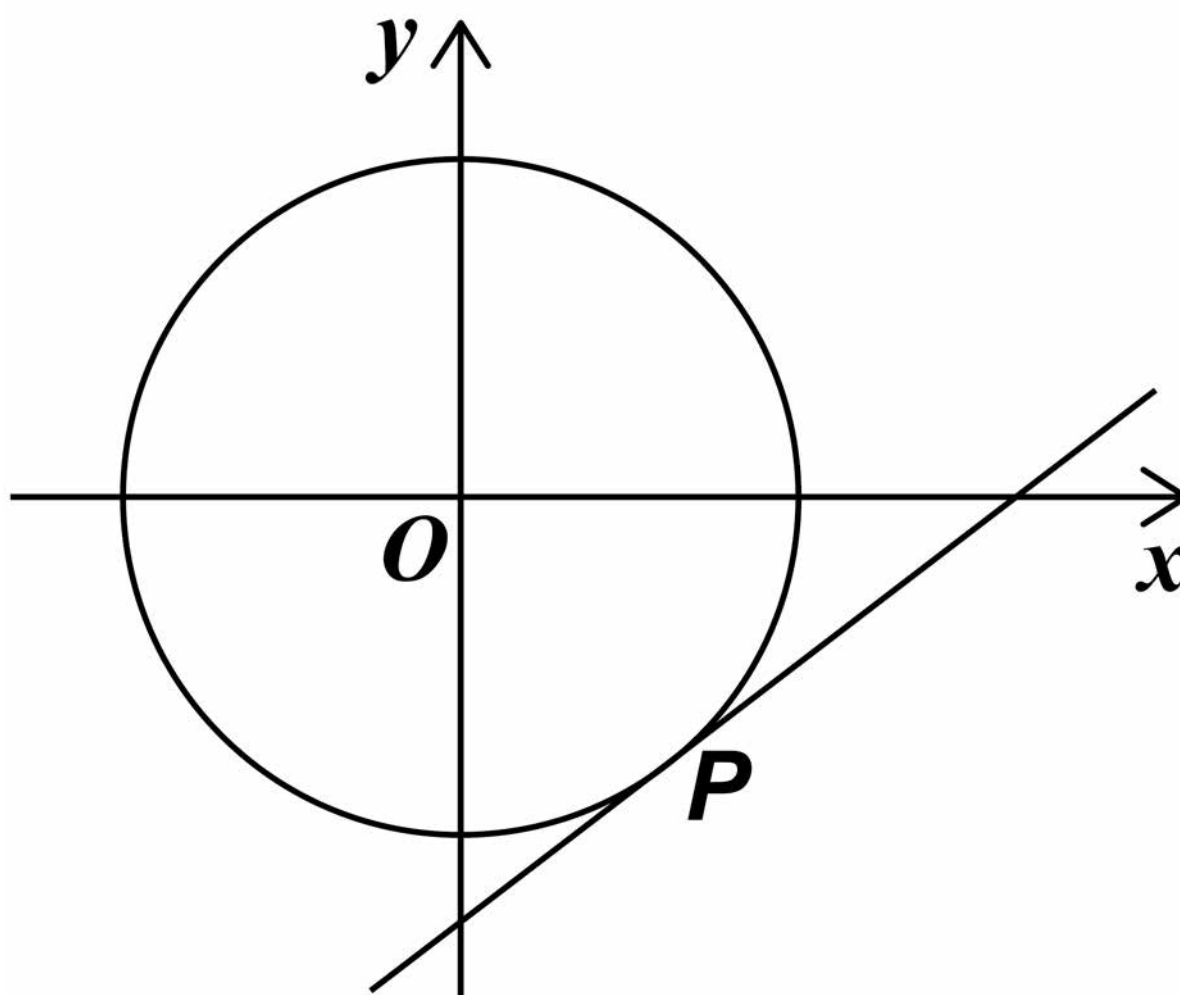

Work out the equation of the tangent to the circle at  $P$ .  
[5 marks]

51

---

---

---

---

---

---

---

---

---

---

---

---

---

---

---

---

---

---

---

---

---

---

---

---

Answer \_\_\_\_\_

**END OF QUESTIONS**

8



# There are no questions printed on this page

For Examiner's Use	
Pages	Mark
4–6	
7–11	
12–15	
16–19	
20–23	
24–27	
28–31	
32–35	
36–39	
40–43	
44–46	
47–51	
<b>TOTAL</b>	

## Copyright information

For confidentiality purposes, from the November 2015 examination series, acknowledgements of third party copyright material will be published in a separate booklet rather than including them on the examination paper or support materials. This booklet is published after each examination series and is available for free download from [www.aqa.org.uk](http://www.aqa.org.uk) after the live examination series.

Permission to reproduce all copyright material has been applied for. In some cases, efforts to contact copyright-holders may have been unsuccessful and AQA will be happy to rectify any omissions of acknowledgements. If you have any queries please contact the Copyright Team, AQA, Stag Hill House, Guildford, GU2 7XJ

Copyright © 2018 AQA and its licensors. All rights reserved.

# IB/M/Jun18/CH/8300/3H/E3

