



# Cambridge IGCSE™

---

**PHYSICAL SCIENCE**

**0652/51**

Paper 5 Practical Test

**October/November 2025**

CONFIDENTIAL INSTRUCTIONS

**This document gives details of how to prepare for and administer the practical exam.**

**The information in this document and the identity of any materials supplied by Cambridge International are confidential and must NOT reach candidates either directly or indirectly.**

**The supervisor must complete the report at the end of this document and return it with the scripts.**

---

## INSTRUCTIONS

- If you have any queries regarding these confidential instructions, contact Cambridge International stating the centre number, the syllabus and component number and the nature of the query.  
email      [info@cambridgeinternational.org](mailto:info@cambridgeinternational.org)  
phone      +44 1223 553554

---

This document has **8** pages. Any blank pages are indicated.



## General information about practical exams

Centres must follow the guidance on science practical exams given in the *Cambridge Handbook*.

### Safety

Supervisors must follow national and local regulations relating to safety and first aid.

Only those procedures described in the question paper should be attempted.

Supervisors must inform candidates that materials and apparatus used in the exam should be treated with caution. Suitable eye protection should be used where necessary.

The following hazard codes are used in these confidential instructions, where relevant:

<b>C</b>	corrosive	<b>MH</b>	moderate hazard
<b>HH</b>	health hazard	<b>T</b>	acutely toxic
<b>F</b>	flammable	<b>O</b>	oxidising
<b>N</b>	hazardous to the aquatic environment		

Hazard data sheets relating to substances used in this exam should be available from your chemical supplier.

### Before the exam

- The packets containing the question papers must **not** be opened before the exam.
- It is assumed that standard school laboratory facilities, as indicated in the *Guide to Planning Practical Science*, will be available.
- Spare materials and apparatus for the tasks set must be available for candidates, if required.

### During the exam

- It must be made clear to candidates at the start of the exam that they may request spare materials and apparatus for the tasks set.
- Where specified, the supervisor **must** perform the experiments and record the results as instructed. This must be done **out of sight** of the candidates, using the same materials and apparatus as the candidates.
- Any assistance provided to candidates must be recorded in the supervisor's report.
- If any materials or apparatus need to be replaced, for example, in the event of breakage or loss, this must be recorded in the supervisor's report.

### After the exam

- The supervisor must complete a report for each practical session held and each laboratory used.
- Each packet of scripts returned to Cambridge International must contain the following items:
  - the scripts of the candidates specified on the bar code label provided
  - the supervisor's results relevant to these candidates
  - the supervisor's reports relevant to these candidates
  - seating plans for each practical session, referring to each candidate by candidate number
  - the attendance register.

## Specific information for this practical exam

During the exam, the supervisor (**not** the invigilator) must do the experiments in Questions 1, 2 and 3 and record the results on a spare copy of the question paper, clearly labelled 'supervisor's results'.

### Apparatus for Question 1

Each candidate will require:

- a power supply with an output potential difference (p.d.) of 1.5V–2V. Where candidates are provided with a power supply with a variable output p.d., the p.d. must be set by the supervisor and fixed, e.g. taped (see Note 2)
- a lamp (2.5V, 0.3A) in a suitable holder (see Note 3)
- a resistor of nominal resistance value  $4.7\ \Omega$  with a power rating of at least 2W (see Note 3)
- a switch. The switch may be an integral part of the power supply
- an ammeter capable of reading up to 1.00A with a precision of at least 0.05A (see Note 4)
- a voltmeter capable of measuring the supply p.d. with a precision of at least 0.1V (see Note 4)
- sufficient connecting leads to construct the circuit shown in Fig. 1.1 (see Note 1)
- two additional connecting leads
- spare lamps and resistors should be available.

### Notes

1. The circuit is to be set up for candidates as shown in Fig. 1.1.

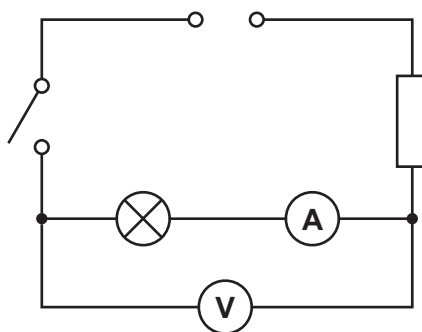

**Fig. 1.1**

2. If cells are to be used, they must remain adequately charged throughout the examination. Spare cells must be available.
3. The lamp and resistor must have suitable terminals so that candidates are able easily and quickly to rearrange the circuit. Spare lamps and resistors should be available.
4. Either analogue or digital meters are suitable. Any variable settings must be set by the supervisor and fixed (e.g. taped). Spare meters should be available.

### Action at changeover

Set up the circuit so that it is arranged as shown in Fig. 1.1. Check that the circuit and all the lamps work. Switch off.

### Apparatus for Question 2

Each candidate will require:

- metre ruler with a mm scale (see Note 1)
- triangular block to act as a pivot for the metre ruler. This block is to stand on the bench (see Note 2)
- masses of 100 g, 150 g, 200 g, 250 g and 300 g labelled **1.0 N**, **1.5 N**, **2.0 N**, **2.5 N** and **3.0 N** respectively (see Note 3)
- an 80 g mass labelled **B** (see Note 4).

### Notes

1. If the metre ruler has two scales in opposite directions, one scale must be taped over.
2. The triangular block can be made of any solid material that is durable enough to support the ruler and the masses. When placed on a surface with its apex pointing upwards, the height of the apex should be about 5–8 cm above the surface.
3. Any suitable masses that can rest on the metre ruler can be used. To make the **3.0 N** load two 100 g slotted masses with a 100 g mass hanger could be taped together. The **1.5 N** load could be a 100 g slotted mass and a 50 g slotted mass taped together.
4. Any suitable masses that can rest on the metre ruler can be used. A set of eight 10 g slotted masses (or seven 10 g slotted masses with a 10 g mass hanger) could be used. The 80 g mass labelled **B** must be taped to the ruler with its centre at the 90.0 cm mark.

### Action at changeover

Remove the loads from the ruler and make sure that mass **B** is still fixed at 90.0 cm. Remove the ruler from the pivot. Check that the apparatus is ready for the next candidate.

**Apparatus and chemicals for Question 3**

Each candidate will require:

- [MH][N]
- 6 spatulas of copper carbonate powder labelled **copper carbonate** (see Note 1)
  - spatula
  - evaporating basin
  - access to a balance with precision of at least 0.1 g (see Note 2)
  - tripod
  - gauze
  - heatproof mat
  - Bunsen burner and a means to light it
  - tongs

**Notes**

1. Basic copper carbonate may be used.
2. Candidates will need to measure the mass three times, two at the beginning of their experiment and one sometime later.

**Apparatus for Question 4**

No chemicals or apparatus are required for this question.

**BLANK PAGE**

---

Permission to reproduce items where third-party owned material protected by copyright is included has been sought and cleared where possible. Every reasonable effort has been made by the publisher (UCLES) to trace copyright holders, but if any items requiring clearance have unwittingly been included, the publisher will be pleased to make amends at the earliest possible opportunity.

To avoid the issue of disclosure of answer-related information to candidates, all copyright acknowledgements are reproduced online in the Cambridge Assessment International Education Copyright Acknowledgements Booklet. This is produced for each series of examinations and is freely available to download at [www.cambridgeinternational.org](http://www.cambridgeinternational.org) after the live examination series.

Cambridge Assessment International Education is part of Cambridge Assessment. Cambridge Assessment is the brand name of the University of Cambridge Local Examinations Syndicate (UCLES), which is a department of the University of Cambridge.

**Supervisor's report**

Syllabus and component number

				/		
--	--	--	--	---	--	--

Centre number

--	--	--	--	--

Centre name .....

Time of the practical session .....

Laboratory name/number .....

**Give details of any difficulties experienced by the centre or by candidates (include the relevant candidate names and candidate numbers).**

You must include:

- any difficulties experienced by the centre in the preparation of materials
- any difficulties experienced by candidates, e.g. due to faulty materials or apparatus
- any specific assistance given to candidates.

**Declaration**

- 1 Each packet that I am returning to Cambridge International contains all of the following items:
  - the scripts of the candidates specified on the bar code label provided
  - the supervisor’s results relevant to these candidates
  - the supervisor’s reports relevant to these candidates
  - seating plans for each practical session, referring to each candidate by candidate number
  - the attendance register.
- 2 Where the practical exam has taken place in more than one practical session, I have clearly labelled the supervisor’s results, supervisor’s reports and seating plans with the time and laboratory name/number for each practical session.
- 3 I have included details of difficulties relating to each practical session experienced by the centre or by candidates.
- 4 I have reported any other adverse circumstances affecting candidates, e.g. illness, bereavement or temporary injury, directly to Cambridge International on a *special consideration form*.

Signed ..... (supervisor)

Name (in block capitals) .....