



Cambridge IGCSE™

CANDIDATE NAME



CENTRE NUMBER

--	--	--	--	--

CANDIDATE NUMBER

--	--	--	--



PHYSICAL SCIENCE

0652/51

Paper 5 Practical Test

October/November 2025

1 hour 15 minutes

You must answer on the question paper.

You will need: The materials and apparatus listed in the confidential instructions

INSTRUCTIONS

- Answer **all** questions.
- Use a black or dark blue pen. You may use an HB pencil for any diagrams or graphs.
- Write your name, centre number and candidate number in the boxes at the top of the page.
- Write your answer to each question in the space provided.
- Do **not** use an erasable pen or correction fluid.
- Do **not** write on any bar codes.
- You may use a calculator.
- You should show all your working and use appropriate units.

INFORMATION

- The total mark for this paper is 40.
- The number of marks for each question or part question is shown in brackets [].
- Notes for use in qualitative analysis are provided in the question paper.

For Examiner's Use	
1	
2	
3	
4	
Total	

This document has **20** pages. Any blank pages are indicated.

- 1 You are going to investigate the resistance of a filament lamp.

The circuit shown in Fig. 1.1 has been assembled for you. This is circuit 1.

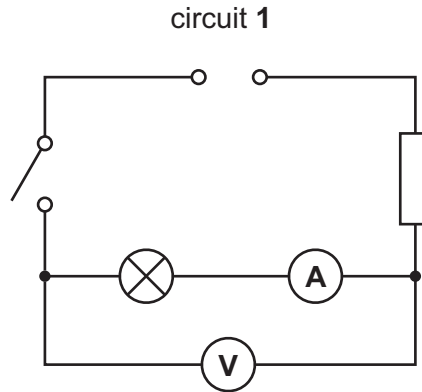

Fig. 1.1

- (a) State how zero errors are avoided when taking an ammeter or a voltmeter reading.

.....

..... [1]

- (b) Refer to Fig. 1.1 when following the procedure.

Procedure

- Close the switch.
- Measure the potential difference V and the current I in the circuit.
- Record in Table 1.1 in the row for circuit 1 these values of V and I .

Table 1.1

circuit	V/V	I/A	R/Ω
1			
2			

- Open the switch.
- Remove the resistor. Do **not** disconnect the voltmeter and the ammeter.
- Connect the resistor in parallel with the lamp and ammeter and reconnect the circuit as shown in circuit 2 in Fig. 1.2.



circuit 2

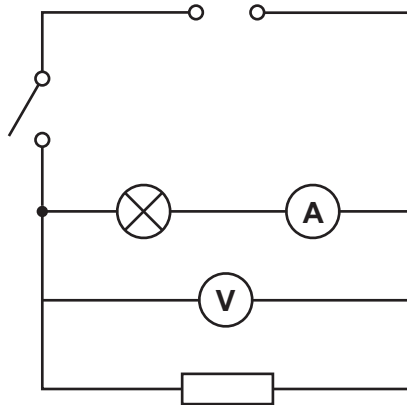

Fig. 1.2

- Close the switch.
- Measure the potential difference V and current I for circuit 2.
- Record in Table 1.1 in the row for circuit 2 these values of V and I .
- Open the switch.

[3]

(c) Calculate the resistance R of the lamp in each circuit.

Use the equation shown.

$$R = \frac{V}{I}$$

Record in Table 1.1 your values of R to **two** significant figures.

[2]

(d) Two values are considered to be the same within the limits of experimental error if they are within 10% of each other.

State if your values of resistance are the same within the limits of experimental error.

Justify your answer by reference to your data in Table 1.1.

Include a calculation in your answer.

.....

..... [2]



DO NOT WRITE IN THIS MARGIN

(e) A student adds an additional resistor to the circuit to create a new circuit arrangement.

You do **not** need to construct this circuit.

Complete the circuit diagram in Fig. 1.3 by:

- adding a voltmeter to measure the potential difference across the filament lamp
- adding an ammeter to measure the current through the filament lamp.

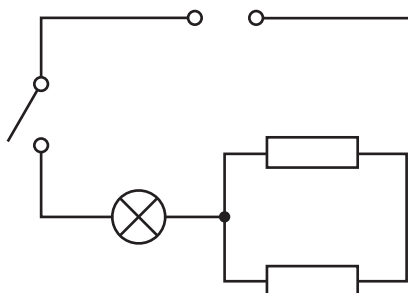

Fig. 1.3

[2]

[Total: 10]





DO NOT WRITE IN THIS MARGIN

Question 2 starts on page 6



2 You are going to determine the weight of a block using a balancing method.

Refer to Fig. 2.1 when following the procedure.

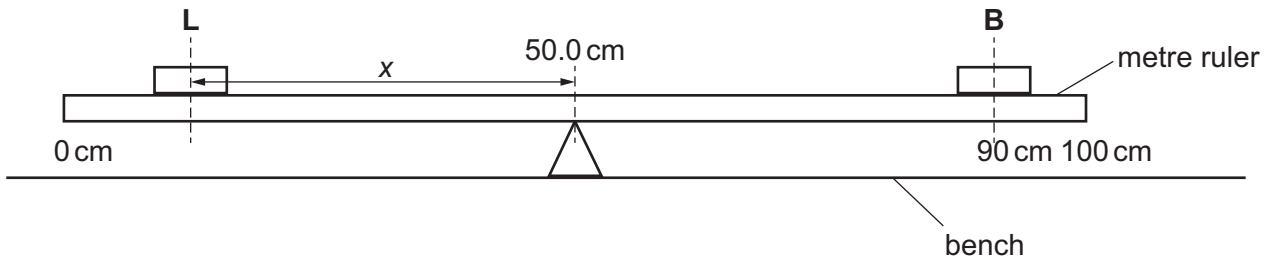

Fig. 2.1

Block **B** is fixed to the metre ruler with its centre at the 90.0 cm mark.

Do **not** adjust the position of **B** during the procedure.

(a) Procedure

- Place the metre ruler on the pivot at the 50.0 cm mark with its scale facing upwards.
- Place the load **L** labelled **1.0 N** on the metre ruler.
- Adjust the position of load **L** so that the metre ruler is as near to being balanced as possible.
- Record in Table 2.1 the distance x of load **L** from the 50.0 cm mark. Record the distance to the nearest 0.1 cm.
- Repeat this procedure using the loads **L** labelled **1.5 N**, **2.0 N**, **2.5 N** and **3.0 N**.

Table 2.1

L/N	x/cm	$\frac{1}{L}/\frac{1}{\text{N}}$
1.0		1.00
1.5		
2.0		0.50
2.5		0.40
3.0		0.33

[3]

(b) Calculate the value of $\frac{1}{L}$ for $L = 1.5 \text{ N}$.

Record in Table 2.1 this value to **two** decimal places.

[1]

(c) On the grid plot $\frac{1}{L}$ (vertical axis) against x .

Do **not** start your graph at the origin (0, 0).

[2]





$$\frac{1}{L} / \frac{1}{N}$$

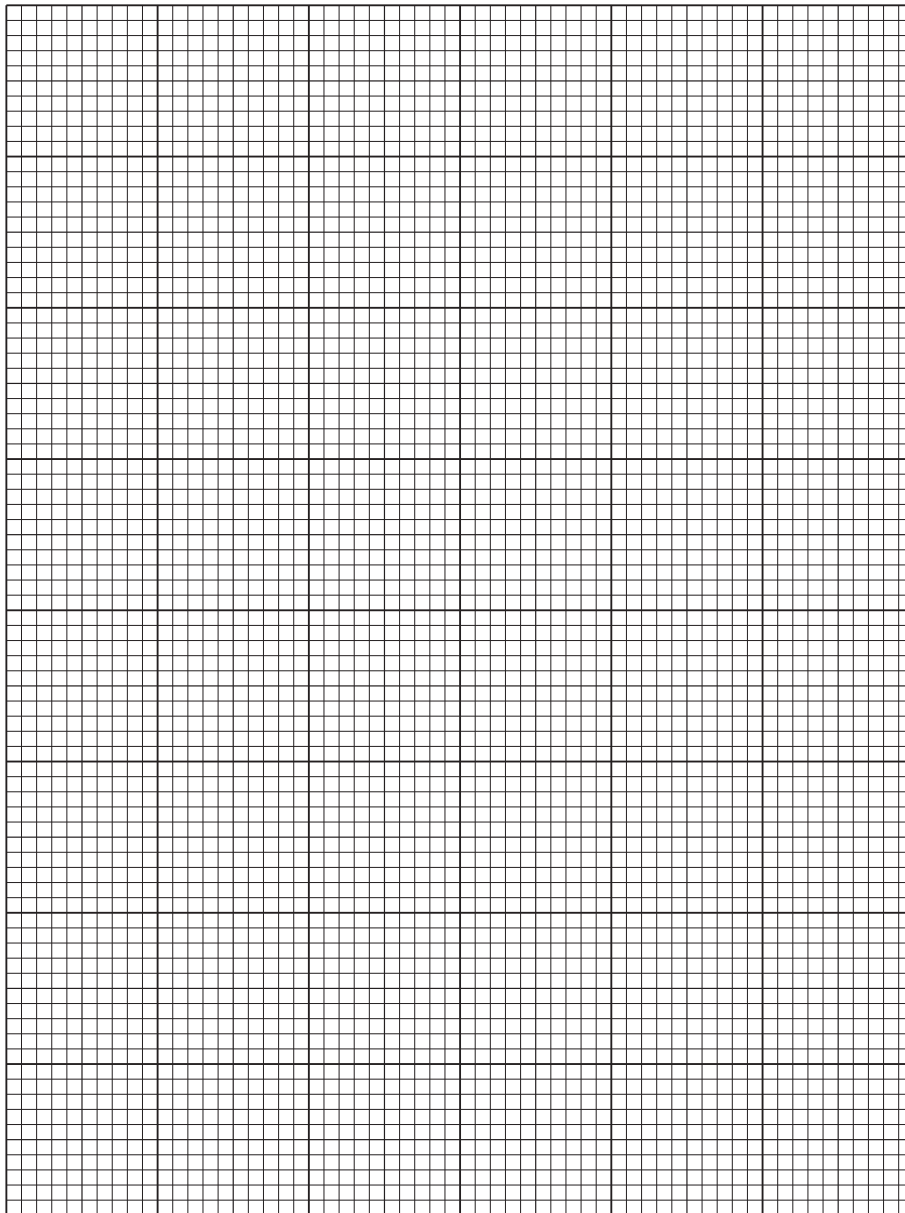

x/cm

(d) Draw the straight line of best fit.

[1]

(e) Calculate the gradient G of the line.

Show your working.

Indicate on your graph the points you use to calculate the gradient.

$G = \dots\dots\dots$ [2]



DO NOT WRITE IN THIS MARGIN



(f) Calculate the weight W of block **B**.

Use the equation shown and your value of G from (e).

$$W = \frac{1}{40G}$$

$W = \dots\dots\dots$ N [1]

[Total: 10]

DO NOT WRITE IN THIS MARGIN

DO NOT WRITE IN THIS MARGIN

DO NOT WRITE IN THIS MARGIN

DO NOT WRITE IN THIS MARGIN

DO NOT WRITE IN THIS MARGIN





Question 3 starts on page 10



DO NOT WRITE IN THIS MARGIN

- 3 You are going to determine the percentage yield of a reaction.

When copper carbonate is heated it forms copper oxide and carbon dioxide gas.



The mass of the copper carbonate decreases as the carbon dioxide is given off.

(a) Procedure

- step 1 Record in Table 3.1 the mass of the empty evaporating basin to the nearest 0.1 g.
- step 2 Add 4 spatulas of copper carbonate to the evaporating basin.
- step 3 Record in Table 3.1 the mass of the evaporating basin and copper carbonate.
- step 4 Put the evaporating basin on a tripod and gauze.
- step 5 Heat the copper carbonate gently for approximately 3 minutes.
- step 6 Turn off the Bunsen burner and leave the evaporating basin to cool down.
The evaporating basin now contains copper oxide.

Complete Question 4 while you are waiting for the copper oxide to cool down.

- step 7 When the evaporating basin is cool, record in Table 3.1 the mass of the evaporating basin and copper oxide to the nearest 0.1 g.

Table 3.1

mass of empty evaporating basin/g	
mass of evaporating basin and copper carbonate (before heating)/g	
mass of evaporating basin and copper oxide (after heating)/g	

[4]

- (b)** State the appearance of the copper carbonate before heating and the copper oxide formed after heating.

copper carbonate

copper oxide

[1]





(c) Draw a labelled diagram of the assembled apparatus used in step 5.

[2]

(d) Suggest how the apparatus can be changed so that the carbon dioxide given off during the reaction is collected and its volume measured.

.....
..... [1]

(e) (i) Calculate the mass of copper carbonate in the evaporating basin.

Use the results in Table 3.1.

mass of copper carbonate =g

Calculate the mass of copper oxide that the experiment is expected to make.

Use the equation shown and your calculated mass of copper carbonate.

mass of copper oxide expected = 0.64 × mass of copper carbonate

expected mass of copper oxide =g
[1]

(ii) Calculate the mass of copper oxide actually made in the reaction.

Use the results in Table 3.1.

mass of copper oxide actually made =g [1]



DO NOT WRITE IN THIS MARGIN



(iii) Calculate the percentage yield of copper oxide formed in the experiment.

Use the equation shown.

$$\text{percentage yield of copper oxide} = \frac{\text{mass of copper oxide actually made, (e)(ii)}}{\text{expected mass of copper oxide, (e)(i)}} \times 100$$

percentage yield of copper oxide = [1]

(f) Suggest an improvement to the experiment that increases confidence in the results.

Explain your answer.

.....
..... [1]

(g) Suggest why the yield is not 100%.

.....
..... [1]

[Total: 13]





Question 4 starts on page 14

DO NOT WRITE IN THIS MARGIN





- 4 When magnesium reacts with dilute hydrochloric acid, aqueous magnesium chloride and hydrogen gas are made.



Plan an experiment to find the relationship between the mass of magnesium used and the volume of hydrogen made.

Assume you are provided with:

- magnesium
- dilute hydrochloric acid.

Assume you have access to any common laboratory apparatus.

You are **not** required to do this experiment.

Include in your plan:

- the apparatus you will use
- a brief description of the method
- the measurements you will make
- the variables you will control
- how you will use your results to reach a conclusion.

You may draw a results table if you wish. You are not required to add any readings to your table.

You may draw a diagram if you wish.

[7]







DO NOT WRITE IN THIS MARGIN



NOTES FOR USE IN QUALITATIVE ANALYSIS

Tests for anions

<i>anion</i>	<i>test</i>	<i>test result</i>
carbonate (CO_3^{2-})	add dilute acid	effervescence, carbon dioxide produced
chloride (Cl^-) [in solution]	acidify with dilute nitric acid, then add aqueous silver nitrate	white ppt.
bromide (Br^-) [in solution]	acidify with dilute nitric acid, then add aqueous silver nitrate	cream ppt.
nitrate (NO_3^-) [in solution]	add aqueous sodium hydroxide, then aluminium foil; warm carefully	ammonia produced
sulfate (SO_4^{2-}) [in solution]	acidify, then add aqueous barium nitrate	white ppt.

Tests for aqueous cations

<i>cation</i>	<i>effect of aqueous sodium hydroxide</i>	<i>effect of aqueous ammonia</i>
ammonium (NH_4^+)	ammonia produced on warming	–
calcium (Ca^{2+})	white ppt., insoluble in excess	no ppt. or very slight white ppt.
copper(II) (Cu^{2+})	light blue ppt., insoluble in excess	light blue ppt., soluble in excess, giving a dark blue solution
iron(II) (Fe^{2+})	green ppt., insoluble in excess	green ppt., insoluble in excess
iron(III) (Fe^{3+})	red-brown ppt., insoluble in excess	red-brown ppt., insoluble in excess
zinc (Zn^{2+})	white ppt., soluble in excess, giving a colourless solution	white ppt., soluble in excess, giving a colourless solution



**Tests for gases**

<i>gas</i>	<i>test and test result</i>
ammonia (NH ₃)	turns damp red litmus paper blue
carbon dioxide (CO ₂)	turns limewater milky
chlorine (Cl ₂)	bleaches damp litmus paper
hydrogen (H ₂)	'pops' with a lighted splint
oxygen (O ₂)	relights a glowing splint

Flame tests for metal ions

<i>metal ion</i>	<i>flame colour</i>
lithium (Li ⁺)	red
sodium (Na ⁺)	yellow
potassium (K ⁺)	lilac
copper(II) (Cu ²⁺)	blue-green





Permission to reproduce items where third-party owned material protected by copyright is included has been sought and cleared where possible. Every reasonable effort has been made by the publisher (UCLES) to trace copyright holders, but if any items requiring clearance have unwittingly been included, the publisher will be pleased to make amends at the earliest possible opportunity.

To avoid the issue of disclosure of answer-related information to candidates, all copyright acknowledgements are reproduced online in the Cambridge Assessment International Education Copyright Acknowledgements Booklet. This is produced for each series of examinations and is freely available to download at www.cambridgeinternational.org after the live examination series.

Cambridge Assessment International Education is part of Cambridge Assessment. Cambridge Assessment is the brand name of the University of Cambridge Local Examinations Syndicate (UCLES), which is a department of the University of Cambridge.

