



Cambridge IGCSE™ (9–1)

PHYSICS

0972/21

Paper 2 Multiple Choice (Extended)

October/November 2025

45 minutes

You must answer on the multiple choice answer sheet.

You will need: Multiple choice answer sheet
Soft clean eraser
Soft pencil (type B or HB is recommended)

INSTRUCTIONS

- There are **forty** questions on this paper. Answer **all** questions.
- For each question there are four possible answers **A, B, C** and **D**. Choose the **one** you consider correct and record your choice in soft pencil on the multiple choice answer sheet.
- Follow the instructions on the multiple choice answer sheet.
- Write in soft pencil.
- Write your name, centre number and candidate number on the multiple choice answer sheet in the spaces provided unless this has been done for you.
- Do **not** use correction fluid.
- Do **not** write on any bar codes.
- You may use a calculator.
- Take the weight of 1.0 kg to be 9.8 N (acceleration of free fall = 9.8 m/s^2).

INFORMATION

- The total mark for this paper is 40.
- Each correct answer will score one mark.
- Any rough working should be done on this question paper.

This document has **16** pages. Any blank pages are indicated.



- 1 A student determines the diameter of a metal ball.

Which apparatus is needed to get an accurate measurement?

- A a ruler and a protractor
- B a ruler only
- C a protractor and a set square
- D a ruler and two rectangular blocks

- 2 An athlete runs at a speed of 8 m/s for 10 s, and then at a speed of 6 m/s for 12 s.

Which calculation gives the average speed of the athlete in m/s?

- A $\frac{8+6}{2}$
- B $\frac{(8 \times 10) + (6 \times 12)}{22}$
- C $\frac{(8 \div 10) + (6 \div 12)}{22}$
- D $\frac{(10 \div 8) + (12 \div 6)}{22}$

- 3 A piece of paper torn out of an exercise book is shown.

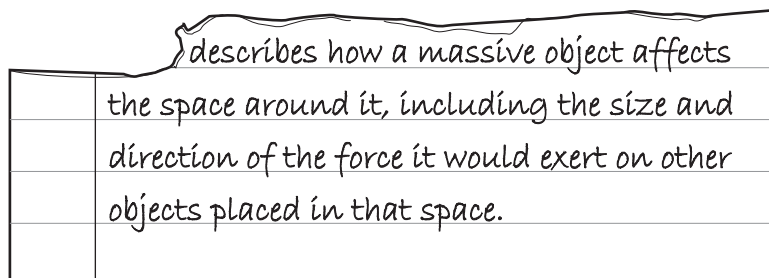

What is being described?

- A gravitational charge
- B gravitational field
- C gravitational mass
- D gravitational potential energy

- 4 The diagram shows one liquid floating on top of another liquid.

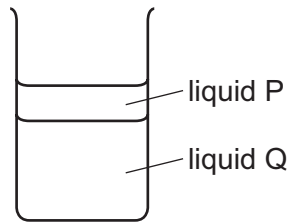

Which statement explains why liquid P floats on top of liquid Q?

- A** The mass of liquid Q is greater than the mass of liquid P.
- B** The mass of 1 cm^3 of liquid Q is greater than the mass of 1 cm^3 of liquid P.
- C** The volume of liquid Q is greater than the volume of liquid P.
- D** The volume of 1 g of liquid Q is greater than the volume of 1 g of liquid P.
- 5 A spring has a spring constant k .
- What is a possible unit for k ?
- A** metre per newton
- B** newton metre
- C** newton per metre
- D** newton per metre squared
- 6 Which statement about the moment of a force is **not** correct?
- A** If an object is balanced about a pivot, the resultant moment on the object must be zero.
- B** The moment of a force is a measure of its turning effect.
- C** The moment of a force about a point is equal to: force \times perpendicular distance from the point.
- D** The moment of a force about a point increases when the perpendicular distance of the force from the point decreases.
- 7 The momentum of a car changes from $10\,000 \text{ kg m/s}$ to $15\,000 \text{ kg m/s}$ in a time of 8.0 s .

What is the resultant force acting on the car?

- A** 630 N **B** 3100 N **C** 40 000 N **D** 200 000 N

8 A machine is very efficient.

What does this mean?

- A It produces a large amount of power.
- B It uses very little energy.
- C It wastes very little energy.
- D It works very quickly.

9 Diagram 1 shows a conical flask containing water.

Diagram 2 shows a beaker with the same base area as the flask and containing water of the same depth d .

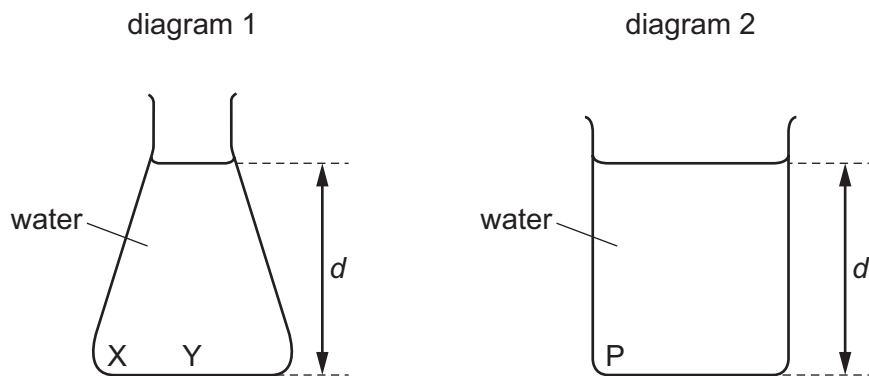

Which statement is correct?

- A The pressure at P is equal to the pressure at X.
- B The pressure at P is greater than the pressure at Y.
- C The pressure at P is greater than the pressure at X.
- D The pressure at Y is greater than the pressure at X.

- 10 A flask with a tight-fitting stopper contains a gas. The gas and flask are initially at room temperature.

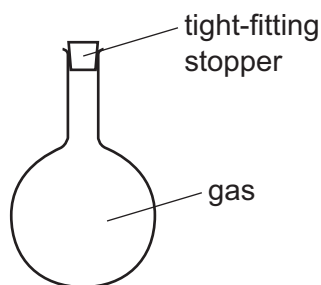

The gas and flask are cooled.

Which row describes the average speed of the gas particles and the pressure of the gas as the temperature decreases?

	average speed of the gas particles	pressure of the gas
A	decreases	decreases
B	decreases	stays the same
C	increases	increases
D	increases	stays the same

- 11 Brownian motion is the random movement of microscopic particles in a liquid or gas.

Which statement about Brownian motion is correct?

- A** Brownian motion only occurs when the liquid or gas is heated.
- B** Much heavier fast-moving particles that **cannot** be seen collide with the microscopic particles.
- C** Much lighter fast-moving particles that **cannot** be seen collide with the microscopic particles.
- D** The microscopic particles move to avoid the fast-moving liquid or gas molecules.
- 12 The distance between two electricity pylons is 60 m. The cable that connects the two pylons is 62 m in length.

Why is the cable longer than the distance between the two pylons?

- A** to allow for contraction of the cable in cold weather
- B** to create a slope in the cable for electrons to flow down
- C** to keep the current low and the voltage high
- D** to reduce magnetic fields around the cable

- 13 A glass beaker contains a mass of 0.20 kg of water at a temperature of 20 °C.

The specific heat capacity of water is 4200 J/(kg °C).

A brass block of mass 0.15 kg is at a temperature of 170 °C. The block is carefully lowered into the beaker of water.

The final temperature of both the water and brass is 30 °C.

What is the specific heat capacity of the brass?

(Assume that no water is lost and no thermal energy has been transferred to the beaker or the surroundings.)

- A 400 J/(kg °C)
 - B 660 J/(kg °C)
 - C 1200 J/(kg °C)
 - D 5600 J/(kg °C)
- 14 Which statement about convection is **not** correct?
- A It enables water in a pan on a cooker to get evenly heated.
 - B It happens in liquids and gases.
 - C It occurs because cooler liquids rise above warmer liquids.
 - D It occurs because the density of a liquid decreases when it is heated.
- 15 Iron is a better conductor of thermal energy than rubber.

Which statement explains this?

- A Electrons in iron can move from one part of the iron to another. Electrons in rubber **cannot** move in this way.
- B Electrons in iron vibrate with more energy than those in rubber.
- C Positive particles in iron can move from one part of the iron to another. Positive particles in rubber **cannot** move in this way.
- D Positive particles in iron vibrate with more energy than those in rubber.

- 16** Two metal cans are identical, except that one has a shiny silver outer surface and the other has a dull black outer surface. They each have the same mass of hot water at the same temperature sealed inside them. They are both in a vacuum in the darkness of outer space.

How does the temperature of the water in each one change?

- A** The temperature of the water does **not** change.
- B** The water in the black can cools more slowly than that in the silver can.
- C** The water in the silver can cools more slowly than that in the black can.
- D** They both cool down at the same rate.
- 17** A ray of light reflects from a plane mirror.

The angle between the incident ray and the surface of the mirror is 35° .

Which statement is correct?

- A** The angle of incidence is 35° .
- B** The angle of incidence is 55° .
- C** The angle of reflection is 70° .
- D** The angle of reflection is 110° .

- 18** Parallel waves in a ripple tank are diffracted as they pass through a gap in a barrier.

Three changes that can be made to this arrangement are listed.

- 1 Decrease the wavelength of the waves.
- 2 Increase the amplitude of the waves.
- 3 Decrease the size of the gap.

Which changes will cause the shape of the diffracted waves to be less curved?

- A** 1, 2 and 3 **B** 1 and 3 only **C** 1 only **D** 2 and 3 only

- 19 A beam of light passes through a vacuum and then enters a transparent liquid. The diagram shows the path it takes.

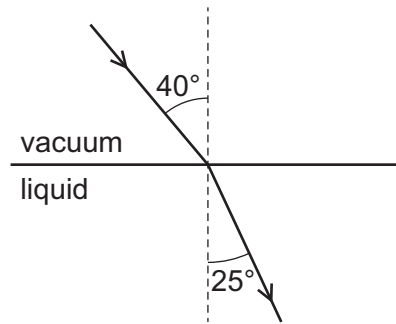

The light travels through the vacuum at a speed of 3.0×10^8 m/s.

What is the speed of light in the liquid?

- A 1.9×10^8 m/s
 - B 2.0×10^8 m/s
 - C 4.6×10^8 m/s
 - D 4.8×10^8 m/s
- 20 Which statement about a thin converging lens is correct?
- A All rays of light refracted by the lens pass through the principal focus.
 - B All rays initially parallel to the principal axis of the lens are refracted through the principal focus.
 - C The focal length of the lens is the distance between the image and the principal focus.
 - D The focal length of the lens is the distance between the object and the image.

- 21 The diagram shows two narrow beams of light, P and then Q, passing through the same prism. Beams P and Q are both incident on the same point on the prism and at the same angle.

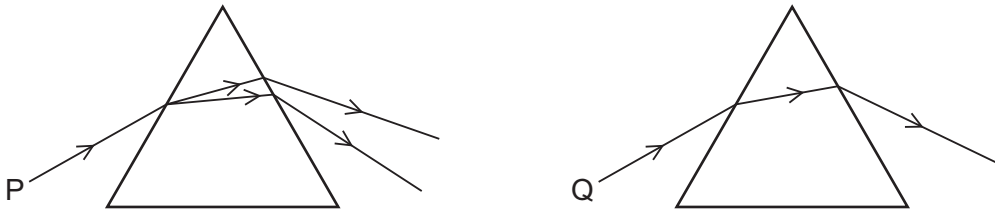

Which row correctly compares beams P and Q?

	dispersion	nature of light
A	only Q is dispersed	P is monochromatic and Q is white light
B	only Q is dispersed	P is white light and Q is monochromatic
C	only P is dispersed	P is monochromatic and Q is white light
D	only P is dispersed	P is white light and Q is monochromatic

- 22 Ultraviolet radiation and infrared radiation are both parts of the electromagnetic spectrum.

However, they differ in wavelength and frequency.

Which row describes how they differ?

	ultraviolet	infrared
A	longer wavelength than infrared	higher frequency than ultraviolet
B	longer wavelength than infrared	lower frequency than ultraviolet
C	shorter wavelength than infrared	higher frequency than ultraviolet
D	shorter wavelength than infrared	lower frequency than ultraviolet

- 23 A police car with its siren sounding is stationary in heavy traffic. A pedestrian notices that, although the loudness of the sound produced does **not** change, the pitch varies.

Which row describes the amplitude and the frequency of the sound?

	amplitude	frequency
A	constant	constant
B	constant	varying
C	varying	constant
D	varying	varying

- 24 The diagram shows part of the magnetic field around two magnets.

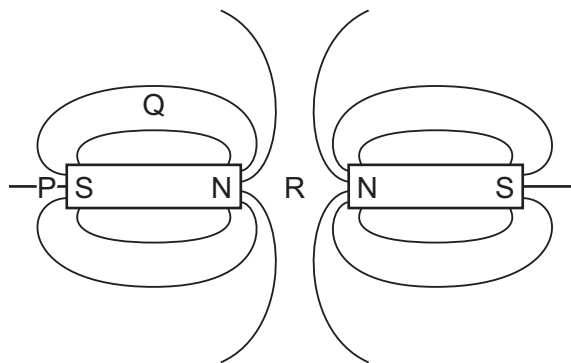

Which list gives the order of magnetic field strengths at the positions P, Q and R, from weakest to strongest?

- A** P → Q → R
 - B** P → R → Q
 - C** Q → P → R
 - D** R → Q → P
- 25 A fully charged battery stores a charge of 18 000 C. The battery is charged with a current of 830 mA.

How long does it take to fully charge a completely discharged battery?

- A** about 10 minutes
- B** about 3.5 hours
- C** about 4 hours
- D** about 6 hours

26 What is the definition of electromotive force?

- A the electrical work done by a source in moving a unit charge around a complete circuit
- B the electrical work done by a unit charge passing through a component
- C the mechanical work done by a source in moving a unit charge around a complete circuit
- D the mechanical work done by a unit charge passing through a component

27 A cell passes a current of 2.0 A in a circuit for 30 s. In this time, the cell transfers 120 J of energy.

What is the electromotive force (e.m.f.) of the cell?

- A 0.50 V B 1.5 V C 2.0 V D 8.0 V

28 The diagram shows two resistors in series connected to a power supply.

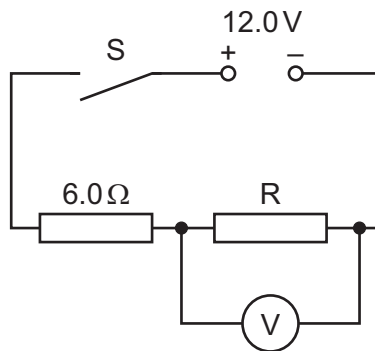

The reading on the voltmeter is 3.0 V when the switch is closed.

What is the resistance of resistor R?

- A 0.67 Ω B 1.2 Ω C 1.5 Ω D 2.0 Ω

29 Lamps can be connected in series or in parallel to a power supply.

What is an advantage of connecting the lamps in parallel rather than in series?

- A All of the lamps can be switched on and off using the same switch.
- B Fewer connecting leads are needed to make the circuit.
- C When one lamp stops working, the others may continue to work.
- D Less power is transferred from the supply.

- 30 The lamps on a bicycle are powered by a simple electrical generator.

A permanent magnet rotates around a stationary coil of wire wound on an iron core.

Which statement is correct?

- A** The current in the lamps decreases as the speed of rotation increases.
- B** The current in the lamps decreases when the magnet is replaced by a stronger magnet.
- C** The output electromotive force (e.m.f.) will be higher if the gap between the magnet and the coil is bigger.
- D** The output e.m.f. will be higher if there are more turns on the coil.
- 31 A current-carrying coil in the magnetic field between the poles of two magnets experiences a turning effect.
- Which change would decrease the turning effect?
- A** decreasing the distance between the magnets
- B** increasing the current in the coil
- C** using stronger magnets
- D** decreasing the number of turns on the coil
- 32 Cables transmit electrical power from the output of the transformer at a power station to the input of another transformer at a substation.

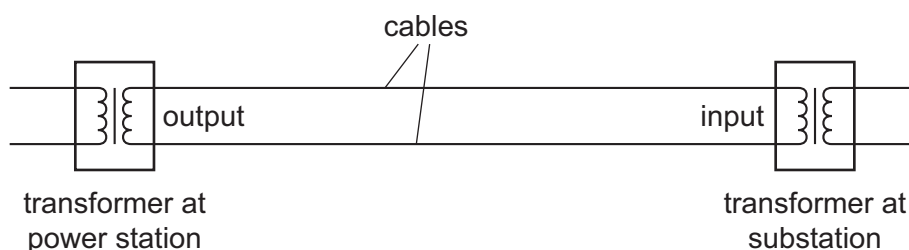

The power at the output of the transformer at the power station is 400 MW.

Which situation delivers the most power to the input of the transformer at the substation?

	potential difference at power station transformer output / kV	diameter of cables
A	200	large
B	200	small
C	400	large
D	400	small

33 $^{239}_{94}\text{Pu}$ is an isotope of plutonium.

The nucleus can absorb a neutron and then split to form two other nuclei.

Two nuclei that form are gold, $^{207}_{79}\text{Au}$, and phosphorus, $^{31}_{15}\text{P}$.

In this reaction, neutrons are also produced.

What is the number of neutrons produced when the nucleus splits?

- A** 1 **B** 2 **C** 4 **D** 5

34 Three statements about alpha (α) particles and beta (β) particles are listed.

- 1 The magnitude of the charge on an α -particle is twice the charge on a β -particle.
- 2 The mass of an α -particle is large compared with the mass of a β -particle.
- 3 The kinetic energy of an α -particle is small compared to the kinetic energy of a β -particle.

Which statements help to explain the different ionising effects of α -particles and β -particles?

- A** 1, 2 and 3 **B** 1 and 2 only **C** 1 and 3 only **D** 2 and 3 only

35 A beta-particle is a fast-moving electron.

Which statement explains how beta-particles are emitted from an atom?

- A** An electron is emitted as a beta-particle from an inner electron shell of the atom.
B An electron is emitted as a beta-particle from an outer electron shell of the atom.
C A neutron changes into a proton and a beta-particle is emitted from the nucleus.
D A proton changes into a neutron and a beta-particle is emitted from the nucleus.

36 Which properties must a radioisotope have for its radiation to make it suitable to kill bacteria in food?

	half-life	type of radiation emitted
A	less than one minute	γ only
B	several hours	α only
C	several hours	γ only
D	several thousand years	α only

- 37 A student tries to predict the effect of exposure time on the radiation dose received from a source of ionising radiation. Radiation dose measures the amount of ionising radiation received by a living organism.

Which graph shows the correct trend between the variables?

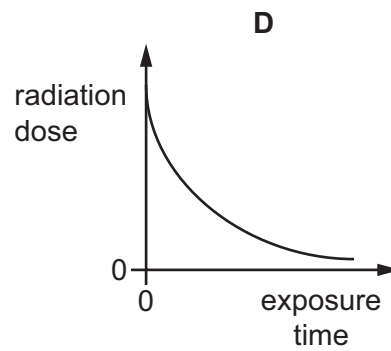
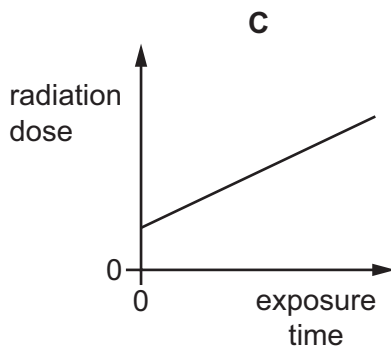
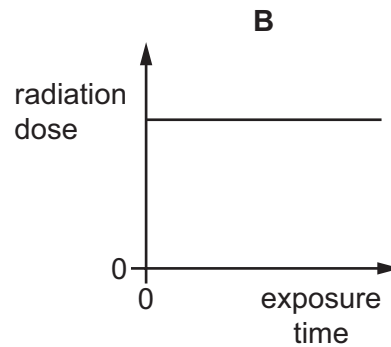
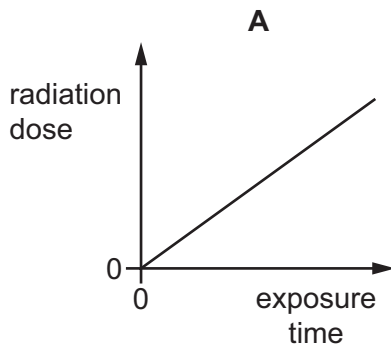

- 38 A satellite is in orbit around the Earth. The orbit has radius r and period T .

Which expression gives the orbital speed of the satellite?

A $\frac{r}{2\pi T}$

B $\frac{T}{2\pi r}$

C $\frac{2\pi r}{T}$

D $\frac{2\pi T}{r}$

- 39 Comets move round the Sun.

Which statement describes the orbit of a comet?

- A** The orbit is circular with the Sun at the centre of the circle.
B The orbit is circular with the Sun **not** at the centre of the circle.
C The orbit is elliptical with the Sun at the centre of the ellipse.
D The orbit is elliptical with the Sun **not** at the centre of the ellipse.

- 40 A galaxy is at a distance of 60 million light-years from the Earth. The galaxy is moving away at a speed of 1300 km/s.

One light-year is about 9.5×10^{12} km.

There are about 3.2×10^7 seconds in one year.

Which expression can be used to estimate the age of the Universe in years?

- A $\frac{60 \times 10^6 \times 3.2 \times 10^7}{1300 \times 9.5 \times 10^{12}}$
- B $\frac{60 \times 10^6 \times 9.5 \times 10^{12}}{1300 \times 3.2 \times 10^7}$
- C $\frac{1300 \times 9.5 \times 10^{12}}{60 \times 10^6 \times 3.2 \times 10^7}$
- D $\frac{1300 \times 3.2 \times 10^7}{60 \times 10^6 \times 9.5 \times 10^{12}}$

BLANK PAGE

Permission to reproduce items where third-party owned material protected by copyright is included has been sought and cleared where possible. Every reasonable effort has been made by the publisher (UCLES) to trace copyright holders, but if any items requiring clearance have unwittingly been included, the publisher will be pleased to make amends at the earliest possible opportunity.

To avoid the issue of disclosure of answer-related information to candidates, all copyright acknowledgements are reproduced online in the Cambridge Assessment International Education Copyright Acknowledgements Booklet. This is produced for each series of examinations and is freely available to download at www.cambridgeinternational.org after the live examination series.

Cambridge Assessment International Education is part of Cambridge Assessment. Cambridge Assessment is the brand name of the University of Cambridge Local Examinations Syndicate (UCLES), which is a department of the University of Cambridge.