



Cambridge IGCSE™ (9–1)

CO-ORDINATED SCIENCES

0973/21

Paper 2 Multiple Choice (Extended)

October/November 2025

45 minutes

You must answer on the multiple choice answer sheet.

You will need: Multiple choice answer sheet
Soft clean eraser
Soft pencil (type B or HB is recommended)

INSTRUCTIONS

- There are **forty** questions on this paper. Answer **all** questions.
- For each question there are four possible answers **A, B, C** and **D**. Choose the **one** you consider correct and record your choice in soft pencil on the multiple choice answer sheet.
- Follow the instructions on the multiple choice answer sheet.
- Write in soft pencil.
- Write your name, centre number and candidate number on the multiple choice answer sheet in the spaces provided unless this has been done for you.
- Do **not** use correction fluid.
- Do **not** write on any bar codes.
- You may use a calculator.
- Take the weight of 1.0 kg to be 9.8 N (acceleration of free fall = 9.8 m/s^2).

INFORMATION

- The total mark for this paper is 40.
- Each correct answer will score one mark.
- Any rough working should be done on this question paper.
- The Periodic Table is printed in the question paper.

This document has **16** pages.



- 1 When light shines from one direction only, a plant shoot bends towards the light.

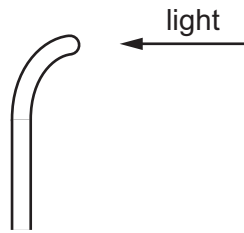

Which row gives the characteristics of living organisms shown by the plant shoot?

	growth	movement	sensitivity
A	no	yes	yes
B	yes	yes	no
C	yes	no	yes
D	yes	yes	yes

- 2 The diagram shows a section through a root hair cell.

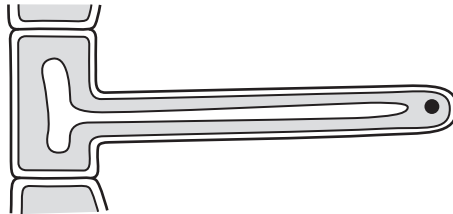

Which statement describes how the structure of the root hair cell relates to its main function?

- A** The nucleus is **not** at the centre of the cell.
- B** The shape helps to support the plant.
- C** The surface area is large.
- D** The volume of the vacuole is small.

- 3 The photograph shows a potato plant. Potato plants have storage organs labelled Y.

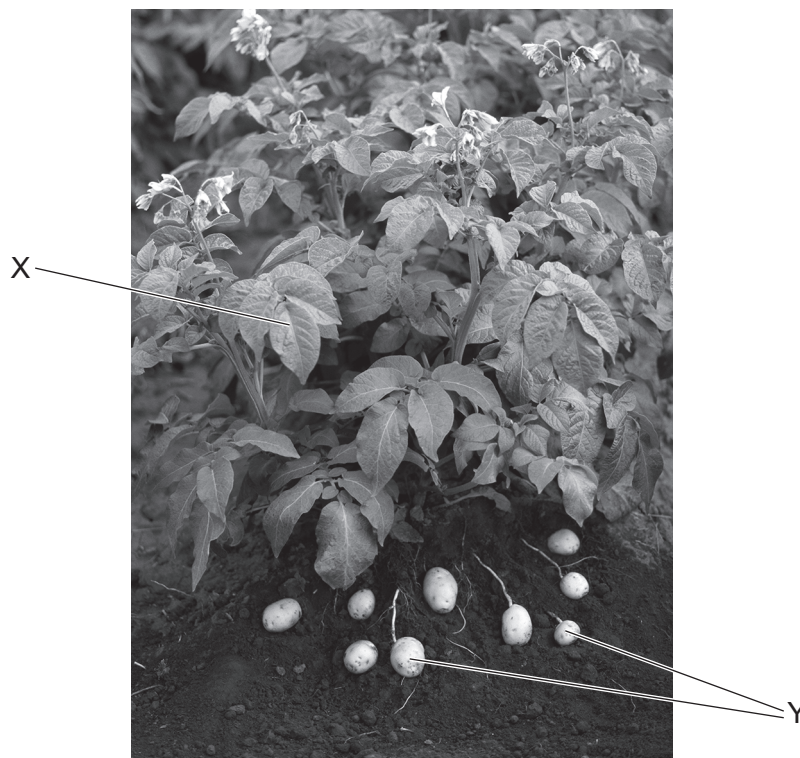

Which statement correctly describes the transport of sucrose in the potato plant?

- A** Sucrose is translocated from X to Y in the phloem.
B Sucrose is translocated from Y to X in the xylem.
C Sucrose is transpired from X to Y in the phloem.
D Sucrose is transpired from Y to X in the xylem.
- 4 A student tests a sample of food for the presence of different biological molecules. The results of the tests are shown.

test	results of test
add iodine solution	orange-brown colour
heat with Benedict's solution	red precipitate formed
add biuret reagent	lilac colour
ethanol emulsion test	clear solution

Which biological molecules are present in the food?

- A** fat and starch
B reducing sugars and protein
C reducing sugars and starch
D starch and protein

5 Enzyme action stops due to denaturation.

What causes denaturation?

- A a change in shape of the active site of the enzyme that occurs at a temperature that is lower than the optimum temperature
- B a change in shape of the active site of the substrate that occurs at a temperature that is lower than the optimum temperature
- C a change in shape of the active site of the enzyme that occurs at a temperature that is higher than the optimum temperature
- D a change in shape of the active site of the substrate that occurs at a temperature that is higher than the optimum temperature

6 The diagram shows a section through a leaf.

Which labelled part enables oxygen to escape from the leaf?

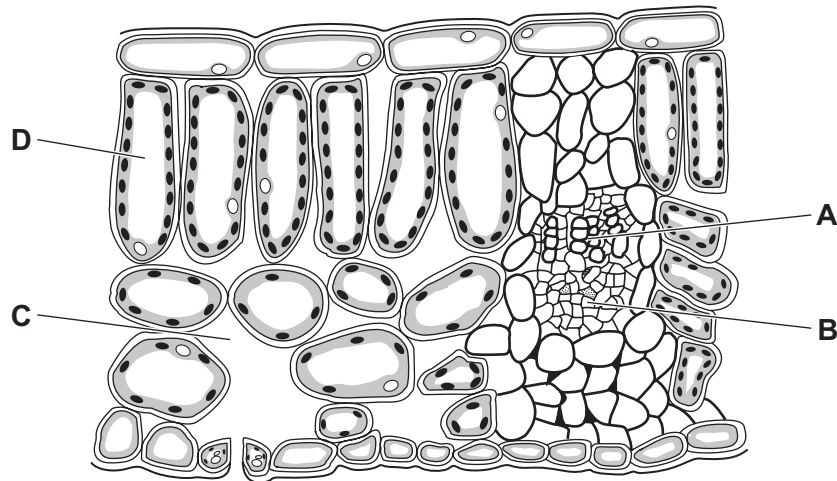

7 Which row about digestion is correct?

	type of digestion	before digestion	after digestion
A	chemical	large pieces of food	small pieces of food
B	chemical	large insoluble molecules	small soluble molecules
C	physical	large soluble molecules	small insoluble molecules
D	physical	large pieces of food	small soluble molecules

8 Which statement about the mammalian circulatory system is correct?

- A The atria contract to send blood directly to the body.
- B The blood passes through the heart once for every complete circulation.
- C The blood travels from the heart to the lungs and then back to the heart.
- D The left ventricle contracts to send blood to the lungs.

- 9 Two flasks are set up as shown. A student breathes out through tube X of flask 1. Another student breathes in through tube Y of flask 2.

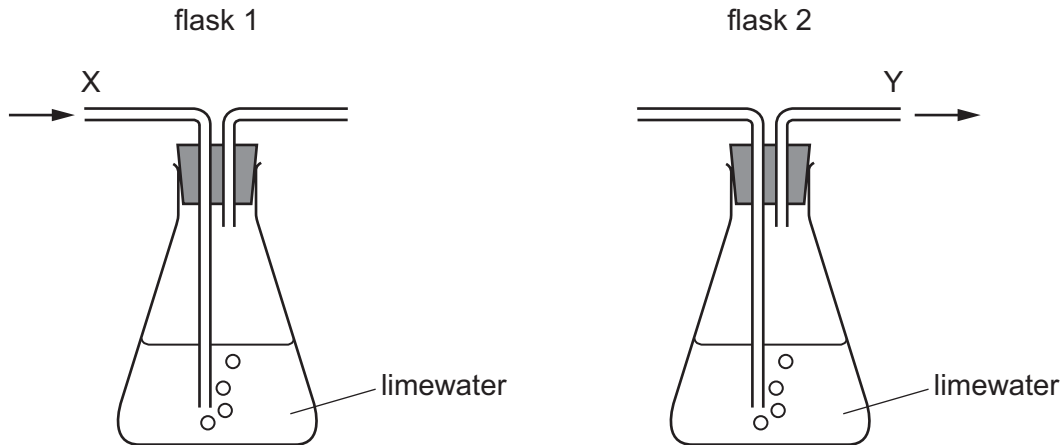

The students obtain different results.

Which body process causes this difference?

- A** absorption
B assimilation
C digestion
D respiration
- 10 A man eats a meal high in carbohydrates. There is only a small change in his blood glucose concentration.
- Which statement explains why?
- A** The pancreas releases insulin and this causes the excess glucose to be stored as glucagon.
B The pancreas releases insulin and this causes the excess glucose to be stored as glycogen.
C The pancreas releases glucagon and this causes the excess glucose to be stored as glycogen.
D The pancreas releases glucagon and this causes the excess glucose to be stored as insulin.
- 11 Three features of flowers are listed.
- 1 anthers located within the petals
 - 2 large colourful petals
 - 3 feathery stigma

Which features are adaptations for wind pollination?

- A** 1 and 2 **B** 1 only **C** 2 and 3 **D** 3 only

12 Chimpanzee gametes contain one more chromosome than human gametes.

What is the chromosome number in a chimpanzee diploid cell?

- A 23 B 24 C 46 D 48

13 Which statement explains why food chains usually have fewer than five trophic levels?

- A All the carnivores consume herbivores.
 B The energy passed on decreases from one trophic level to the next.
 C There is less protein in each individual higher up the chain.
 D There is only one producer in each chain.

14 Which particle has the same number of electrons in its outer shell as an atom of sodium, ${}_{11}^{23}\text{Na}$?

- A ${}_{11}^{23}\text{Na}^+$ B ${}_{11}^{23}\text{Na}^-$ C ${}_{11}^{24}\text{Na}$ D ${}_{12}^{24}\text{Na}^{2+}$

15 Which dot-and-cross diagram shows the outer-shell electrons in a molecule of carbon dioxide?



16 During electrolysis, reactions occur at the cathode and anode.

Which statements about the electrode reactions are correct?

- 1 At the anode, anions gain electrons and are reduced.
- 2 At the anode, anions lose electrons and are oxidised.
- 3 At the cathode, cations gain electrons and are reduced.
- 4 At the cathode, cations lose electrons and are oxidised.

- A 1 and 2 B 1 and 4 C 2 and 3 D 3 and 4

17 Increasing the temperature of a reaction mixture increases the rate of the reaction.

Which statements explain this increase in the rate of the reaction at higher temperatures?

- 1 The activation energy is increased.
- 2 The reacting particles are closer together.
- 3 There are more frequent collisions between reacting particles.
- 4 More collisions between reacting particles result in a reaction.

A 1 and 2 **B** 1 and 4 **C** 2 and 3 **D** 3 and 4

18 Sodium is a metal.

Silicon is a non-metal.

Both sodium and silicon form oxides.

Which statement is correct?

- A** Sodium oxide is acidic and silicon dioxide is basic.
- B** Sodium oxide is basic and silicon dioxide is acidic.
- C** Sodium oxide and silicon dioxide are both acidic.
- D** Sodium oxide and silicon dioxide are both basic.

19 Zinc sulfate is a soluble salt. Zinc sulfate is prepared by reacting zinc with dilute sulfuric acid.

Which statement about this preparation is correct?

- A** Excess dilute sulfuric acid is used and after the reaction has finished the unreacted acid is removed by evaporation.
- B** Excess dilute sulfuric acid is used and after the reaction has finished the unreacted acid is removed by adding an aqueous base.
- C** Excess zinc is used and after the reaction has finished the unreacted zinc is removed by filtration.
- D** Excess zinc is used and after the reaction has finished the zinc sulfate is purified by distillation.

20 Substance Q is added to cold water. Q floats on the water and hydrogen gas is made.

What is Q?

- A** iodine
- B** lithium
- C** magnesium
- D** zinc

21 Which statement about the elements in Group VII of the Periodic Table is correct?

- A Chlorine is more reactive than bromine.
- B The colour of the elements becomes darker up the group.
- C The melting point of the elements decreases down the group.
- D The reactivity of the elements increases down the group.

22 Which row shows the properties of aluminium that make it useful in the manufacture of overhead electrical cables?

	low density	good electrical conductivity
A	no	no
B	no	yes
C	yes	no
D	yes	yes

23 Gasoline and diesel oil are fractions obtained by the fractional distillation of petroleum.

Which row about gasoline and diesel oil is correct?

	temperature at which the fraction is collected	size of molecules in the fraction
A	gasoline higher than diesel oil	gasoline larger than diesel oil
B	gasoline higher than diesel oil	gasoline smaller than diesel oil
C	diesel oil higher than gasoline	diesel oil larger than gasoline
D	diesel oil higher than gasoline	diesel oil smaller than gasoline

24 Which statements about the addition reactions of ethene are correct?

- 1 Ethene reacts with hydrogen to form ethane.
- 2 Ethene reacts with steam to form ethane.
- 3 Ethene undergoes addition reactions because it is a saturated hydrocarbon.
- 4 During addition reactions of ethene, only one product is produced.

- A 1 and 2 B 1 and 4 C 2 and 3 D 3 and 4

25 A section of polymer X is shown.

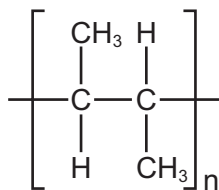

Which statement about X is correct?

- A It is a condensation polymer made from but-1-ene.
- B It is an addition polymer made from but-1-ene.
- C It is a condensation polymer made from but-2-ene.
- D It is an addition polymer made from but-2-ene.

26 The chromatogram for substances P, Q, R and S is shown.

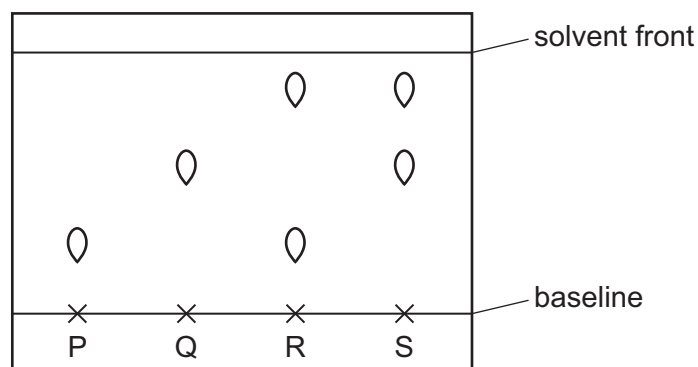

Which statement is correct?

- A P and R are both pure substances.
- B P has a higher R_f value than Q.
- C R is a mixture of P and Q.
- D S is a mixture of Q and one other substance.

27 The results of tests on aqueous G are listed.

- 1 Adding aqueous sodium hydroxide produces a white precipitate that is insoluble in excess.
- 2 Adding acidified aqueous silver nitrate produces a cream precipitate.

What is G?

- A calcium bromide
- B calcium chloride
- C zinc bromide
- D zinc chloride

28 A stone of mass 60g is placed in a measuring cylinder containing water. The water level in the measuring cylinder rises as shown.

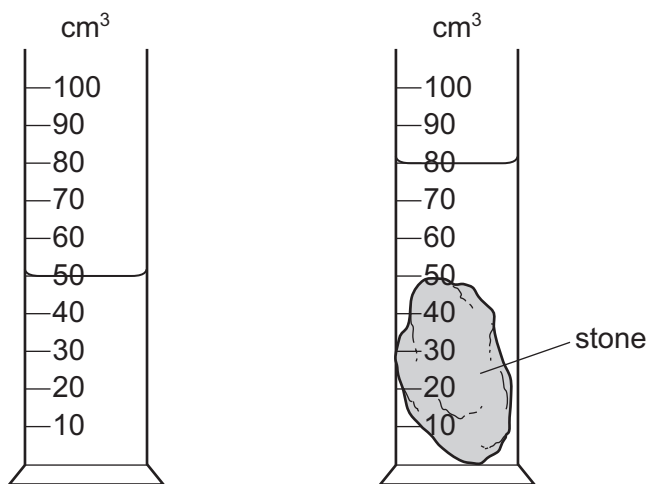

What is the density of the stone?

- A 0.50g/cm³
- B 0.75g/cm³
- C 1.3g/cm³
- D 2.0g/cm³

- 29 The diagram shows the two vertical forces acting on an object of mass m falling through the air.

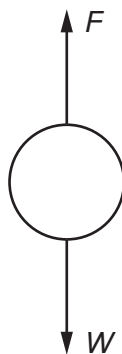

Which expression is equal to the magnitude of the vertical acceleration of the object?

- A** $\frac{(W - F)}{m}$ **B** $\frac{(W + F)}{m}$ **C** $\frac{m}{(W - F)}$ **D** $\frac{m}{(W + F)}$
- 30 The power of sunlight falling on each m^2 of a solar panel is 200 W.
The solar panel has an area of 2.0 m^2 .
The efficiency of the solar panel is 20%.
What is the useful power output of the solar panel?
- A** 80 W **B** 400 W **C** 500 W **D** 2000 W
- 31 Boiling is a process in which a liquid changes its state to become a gas.
Which row describes the temperature at which boiling takes place and where it takes place in a pure liquid?

	temperature	where it takes place
A	at a definite temperature	only at the surface of the liquid
B	at a definite temperature	throughout the liquid
C	at any temperature	only at the surface of the liquid
D	at any temperature	throughout the liquid

- 32 A wave passes a rock in the sea. Five complete wavelengths pass the rock in 20 s.
What is the frequency of this wave?
- A** 0.25 Hz **B** 4.0 Hz **C** 15 Hz **D** 100 Hz

33 In the diagrams, F is one principal focus of the converging lens.

Which diagram shows the use of a lens as a magnifying glass?

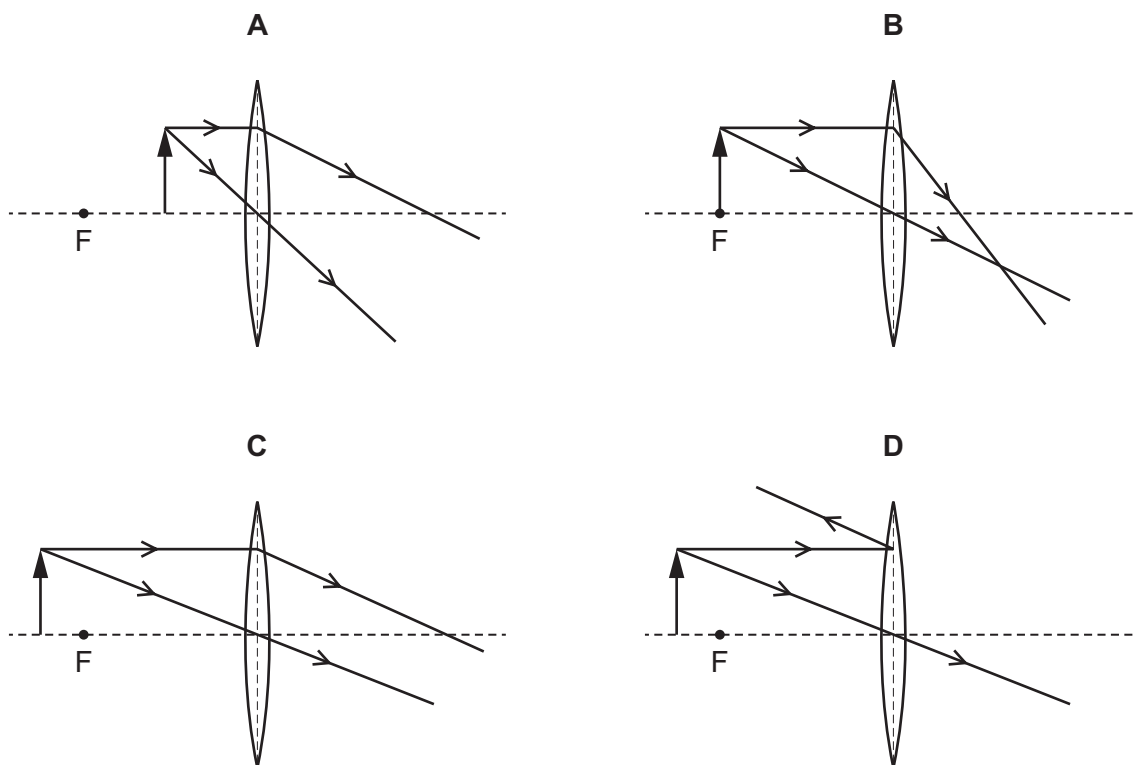

34 The graphs represent the sound waves of sounds P and Q. The graphs are drawn to the same scale.

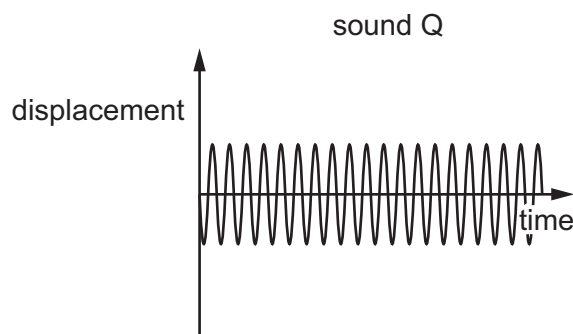
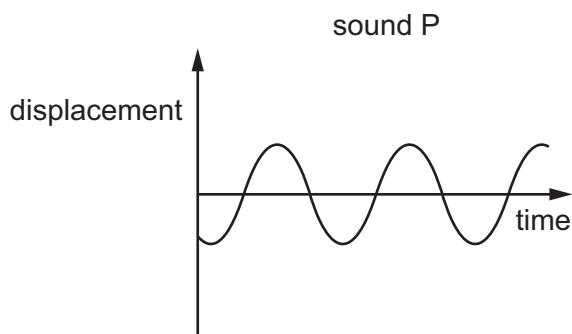

Which statement is correct?

- A Sound P is higher pitched than sound Q.
- B Sound P is louder than sound Q.
- C Sound P is lower pitched than sound Q.
- D Sound P is quieter than sound Q.

35 A ray of light strikes the boundary between water and air.

Which statement describes when the angle of incidence is equal to the critical angle?

- A The light passes from air into water and **no** light is reflected.
- B The light passes from air into water and the angle of refraction is 90° .
- C The light passes from water into air and **no** light is reflected.
- D The light passes from water into air and the angle of refraction is 90° .

36 Which circuit shows an ammeter that measures the current in the lamp and a voltmeter that measures the potential difference (p.d.) across the lamp?

A

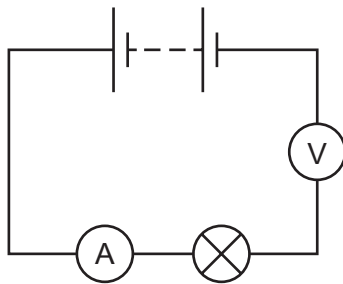

B

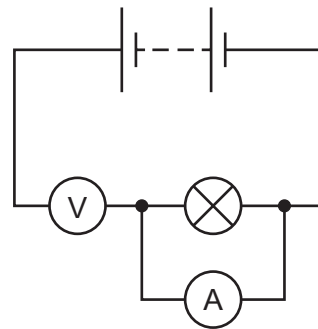

C

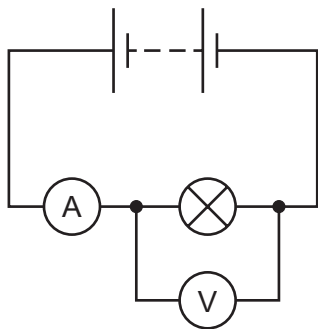

D

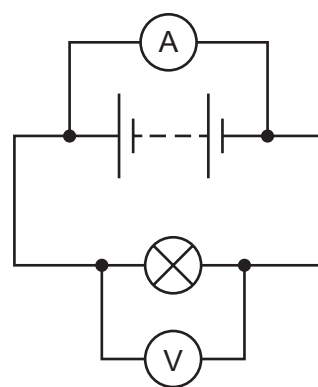

37 The diagram shows the magnetic field around a straight current-carrying wire.

Point X lies in the magnetic field.

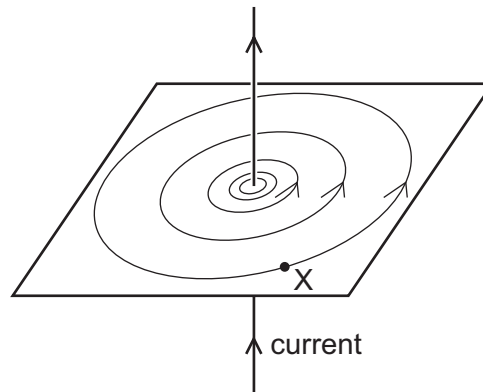

The current is now reduced and its direction is reversed.

Which row shows the effect on the strength and direction of the magnetic field at point X?

	strength of magnetic field	direction of magnetic field
A	decreases	reverses
B	decreases	unchanged
C	increases	reverses
D	increases	unchanged

38 The output from the generator in a power station is connected to a transformer before electricity is sent along a transmission cable.

What is a reason for using this transformer?

- A** to decrease the voltage and decrease the current
- B** to decrease the voltage and increase the current
- C** to increase the voltage and decrease the current
- D** to increase the voltage and increase the current

- 39 A carbon-14 nucleus undergoes β^- decay and produces an isotope of nitrogen.

The decay equation is shown.



Which row gives the values of A and Z ?

	A	Z
A	13	6
B	13	7
C	14	6
D	14	7

- 40 A moon that orbits a planet has an orbit radius of 1.1×10^9 m and an orbital period of 170 hours.

What is the orbital speed of this moon?

- A 3.6×10^3 m/s
- B 1.1×10^4 m/s
- C 6.8×10^5 m/s
- D 4.2×10^{15} m/s

Permission to reproduce items where third-party owned material protected by copyright is included has been sought and cleared where possible. Every reasonable effort has been made by the publisher (UCLES) to trace copyright holders, but if any items requiring clearance have unwittingly been included, the publisher will be pleased to make amends at the earliest possible opportunity.

To avoid the issue of disclosure of answer-related information to candidates, all copyright acknowledgements are reproduced online in the Cambridge Assessment International Education Copyright Acknowledgements Booklet. This is produced for each series of examinations and is freely available to download at www.cambridgeinternational.org after the live examination series.

Cambridge Assessment International Education is part of Cambridge Assessment. Cambridge Assessment is the brand name of the University of Cambridge Local Examinations Syndicate (UCLES), which is a department of the University of Cambridge.

The Periodic Table of Elements

		Group													
I	II	III	IV	V	VI	VII	VIII								
3 Li lithium 7	4 Be beryllium 9	1 H hydrogen 1	5 B boron 11	6 C carbon 12	7 N nitrogen 14	8 O oxygen 16	9 F fluorine 19	10 Ne neon 20							
11 Na sodium 23	12 Mg magnesium 24	Key atomic number atomic symbol name relative atomic mass						17 Cl chlorine 35.5	18 Ar argon 40						
19 K potassium 39	20 Ca calcium 40	26 Fe iron 56	29 Cu copper 64	30 Zn zinc 65	31 Ga gallium 70	32 Ge germanium 73	33 As arsenic 75	34 Se selenium 79	35 Br bromine 80	36 Kr krypton 84					
37 Rb rubidium 85	38 Sr strontium 88	44 Ru ruthenium 101	47 Ag silver 108	48 Cd cadmium 112	49 In indium 115	50 Sn tin 119	51 Sb antimony 122	52 Te tellurium 128	53 I iodine 127	54 Xe xenon 131					
55 Cs caesium 133	56 Ba barium 137	76 Os osmium 190	79 Au gold 197	80 Hg mercury 201	81 Tl thallium 204	82 Pb lead 207	83 Bi bismuth 209	84 Po polonium —	85 At astatine —	86 Rn radon —					
87 Fr francium —	88 Ra radium —	108 Hs hassium —	111 Rg roentgenium —	112 Cn copernicium —	113 Nh nihonium —	114 Fl flerovium —	115 Mc moscovium —	116 Lv livermorium —	117 Ts tennessine —	118 Og oganeson —					
21 Sc scandium 45	22 Ti titanium 48	23 V vanadium 51	24 Cr chromium 52	25 Mn manganese 55	26 Fe iron 56	27 Co cobalt 59	28 Ni nickel 59	29 Cu copper 64	30 Zn zinc 65	31 Ga gallium 70	32 Ge germanium 73	33 As arsenic 75	34 Se selenium 79	35 Br bromine 80	36 Kr krypton 84
39 Y yttrium 89	40 Zr zirconium 91	41 Nb niobium 93	42 Mo molybdenum 96	43 Tc technetium —	44 Ru ruthenium 101	45 Rh rhodium 103	46 Pd palladium 106	47 Ag silver 108	48 Cd cadmium 112	49 In indium 115	50 Sn tin 119	51 Sb antimony 122	52 Te tellurium 128	53 I iodine 127	54 Xe xenon 131
57–71 lanthanoids	72 Hf hafnium 178	73 Ta tantalum 181	74 W tungsten 184	75 Re rhenium 186	76 Os osmium 190	77 Ir iridium 192	78 Pt platinum 195	79 Au gold 197	80 Hg mercury 201	81 Tl thallium 204	82 Pb lead 207	83 Bi bismuth 209	84 Po polonium —	85 At astatine —	86 Rn radon —
89–103 actinoids	104 Rf rutherfordium —	105 Db dubnium —	106 Sg seaborgium —	107 Bh bohrium —	108 Hs hassium —	109 Mt meitnerium —	110 Ds darmstadtium —	111 Rg roentgenium —	112 Cn copernicium —	113 Nh nihonium —	114 Fl flerovium —	115 Mc moscovium —	116 Lv livermorium —	117 Ts tennessine —	118 Og oganeson —

lanthanoids

actinoids

57 La lanthanum 139	58 Ce cerium 140	59 Pr praseodymium 141	60 Nd neodymium 144	61 Pm promethium —	62 Sm samarium 150	63 Eu europium 152	64 Gd gadolinium 157	65 Tb terbium 159	66 Dy dysprosium 163	67 Ho holmium 165	68 Er erbium 167	69 Tm thulium 169	70 Yb ytterbium 173	71 Lu lutetium 175
89 Ac actinium —	90 Th thorium 232	91 Pa protactinium 231	92 U uranium 238	93 Np neptunium —	94 Pu plutonium —	95 Am americium —	96 Cm curium —	97 Bk berkelium —	98 Cf californium —	99 Es einsteinium —	100 Fm fermium —	101 Md mendelevium —	102 No nobelium —	103 Lr lawrencium —

The volume of one mole of any gas is 24 dm³ at room temperature and pressure (r.t.p.).