



Cambridge O Level

CANDIDATE NAME



CENTRE NUMBER

--	--	--	--	--

CANDIDATE NUMBER

--	--	--	--



COMBINED SCIENCE

5129/32

Paper 3 Experimental Skills and Investigations

October/November 2025

1 hour

You must answer on the question paper.

No additional materials are needed.

INSTRUCTIONS

- Answer **all** questions.
- Use a black or dark blue pen. You may use an HB pencil for any diagrams or graphs.
- Write your name, centre number and candidate number in the boxes at the top of the page.
- Write your answer to each question in the space provided.
- Do **not** use an erasable pen or correction fluid.
- Do **not** write on any bar codes.
- You may use a calculator.
- You should show all your working and use appropriate units.

INFORMATION

- The total mark for this paper is 40.
- The number of marks for each question or part question is shown in brackets [].

This document has **16** pages. Any blank pages are indicated.





1 The enzyme lipase digests fats. Fatty acids are produced from the fats by the digestion.

Milk has a pH value of 6.5. When the fat in milk is digested by lipase, the concentration of fatty acids increases. This lowers the pH value of the milk.

A student investigates the effect of temperature on the rate of fat digestion by lipase.

procedure

The student:

- places a test-tube containing 10 cm³ of milk in a water-bath set at 20 °C
- places a test-tube containing 2 cm³ of lipase solution in the same water-bath
- mixes the contents of the two test-tubes together when they are both at a temperature of 20 °C
- measures and records the time taken for the pH of the milk and lipase solution to fall from pH6.5 to pH5.0.

The student repeats the procedure with the water-bath set at 30 °C, 40 °C, 50 °C and 60 °C.

(a) (i) State the name of the apparatus that the student uses to measure the volume of the solutions.

..... [1]

(ii) State **two** variables that the student should keep constant to ensure that the investigation is a fair test.

variable 1

.....

variable 2

.....

[2]

(b) Fig. 1.1 shows the student's results recorded in a notebook.

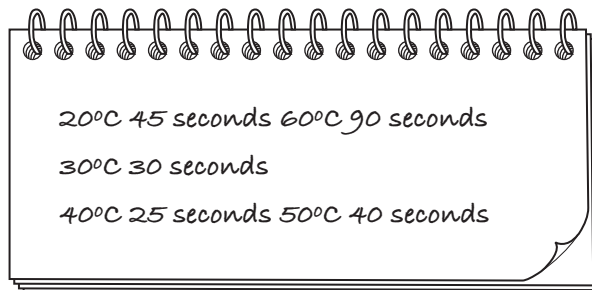

Fig. 1.1





- (i) Complete Table 1.1 by writing appropriate units in the header and entering the student's results shown in Fig. 1.1.

Table 1.1

temperature of the water-bath/	time taken for milk to reach pH 5.0/

[2]

- (ii) Use the information in Table 1.1 to predict the temperature at which lipase digests fat most quickly.

temperature = °C [1]

- (iii) Suggest an improvement to the procedure to find a more accurate value of the temperature at which lipase digests fat most quickly.

.....

.....

..... [2]

- (c) The student knows that lipase is a protein.

State the name, initial colour and final colour of the chemical used to show that lipase is still present in the mixture after the fat has been digested.

name of chemical

initial colour

final colour

[3]

[Total: 11]



DO NOT WRITE IN THIS MARGIN

2 A student investigates a colourless solution.

The student uses the apparatus in Fig. 2.1.

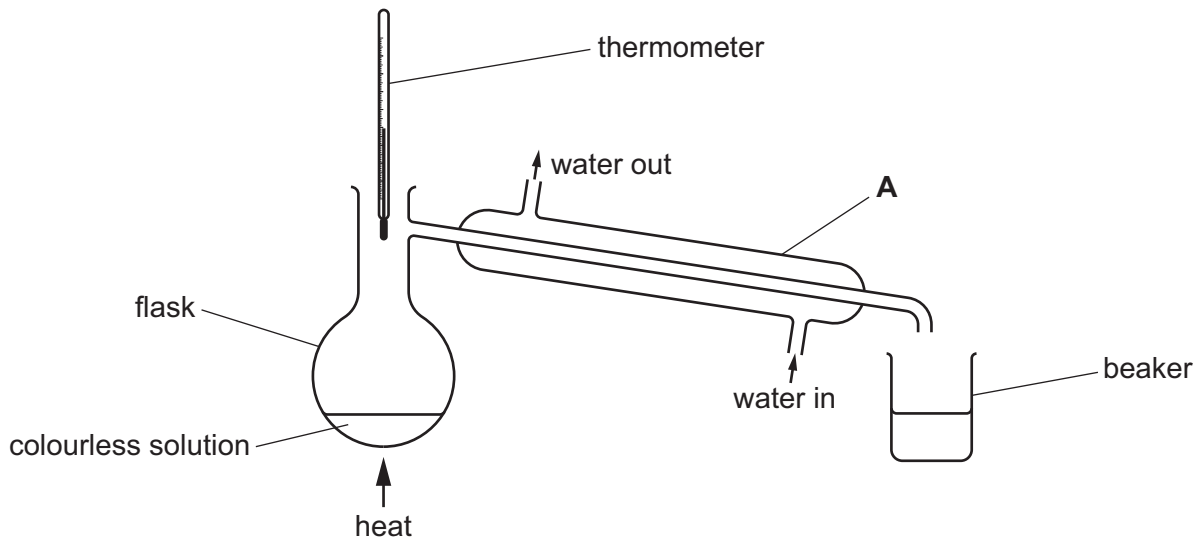

Fig. 2.1

(a) State the name of apparatus A.

..... [1]

(b) The student makes an error assembling the apparatus.

Draw a circle around the part of the apparatus shown in Fig. 2.1 that is assembled incorrectly.

Describe the effect of the error in the circled part of the apparatus, and explain how the error is corrected.

effect of error

.....

correction

.....

[3]



(c) The student corrects the error in the apparatus and heats the colourless solution in the flask. The temperature shown on the thermometer increases and then becomes constant.

Fig. 2.2 shows the initial temperature and the final temperature on the thermometer.

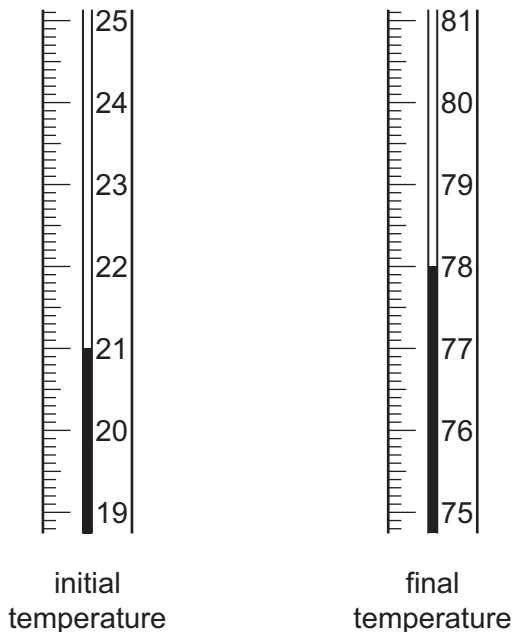

Fig. 2.2

(i) Record the initial and final temperatures.

initial temperature°C

final temperature°C

[1]

(ii) Calculate the temperature change.

temperature change =°C [1]

(iii) State the boiling point of the liquid collected in the beaker.

..... [1]



DO NOT WRITE IN THIS MARGIN



(d) (i) The student heats the flask until all the liquid evaporates.

A white solid remains in the flask.

The student does a flame test on the white solid, and the flame turns lilac.

Use this observation to identify the cation present in the white solid.

..... [1]

(ii) The student places the white solid into a test-tube and adds water.

A solution is formed.

The student tests the solution with universal indicator paper and concludes that the solution has a pH value of 14.

Describe what the student observes that leads to this conclusion.

..... [1]

(iii) Use the information from (d)(ii) to identify the anion present in the solution.

..... [1]

(iv) The student places some of the solution from (d)(ii) into a test-tube and adds litmus solution.

The student then adds dilute hydrochloric acid to the test-tube until no further change is seen.

Describe the colour change that is observed.

.....
..... [1]

[Total: 11]

DO NOT WRITE IN THIS MARGIN



* 00080000007 *

DFD



BLANK PAGE

DO NOT WRITE IN THIS MARGIN





3 A student investigates the extension of a plastic material used to make food bags.

procedure

The student:

- cuts a loop of the plastic material from a food bag
- hangs the loop of the plastic material on a rod
- places a load on the loop as shown in Fig. 3.1
- holds the load.

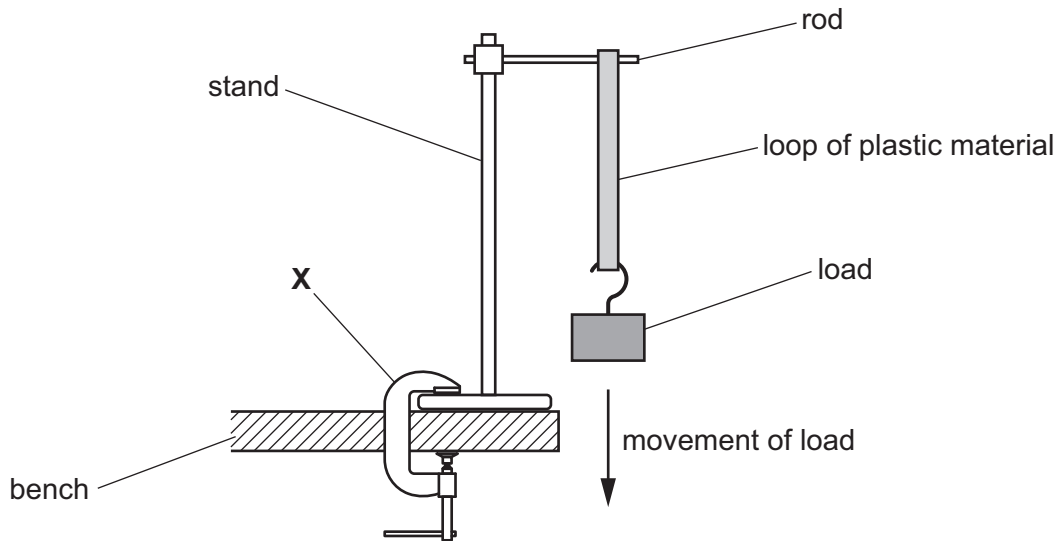

Fig. 3.1

(a) State the name of the apparatus labelled X.

Explain why it is used in this arrangement.

name of apparatus

explanation

.....

[2]



(b) procedure

The student:

- places a metre rule near the load
- releases the load and starts a stopwatch
- records the position of the bottom of the load at different times
- stops the stopwatch when the load is no longer moving.

Fig. 3.2 shows the position of the load before it is released, and Fig. 3.3 shows the position of the load 5 seconds after it is released.

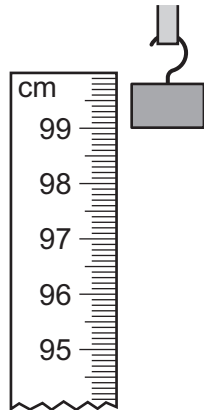

Fig. 3.2

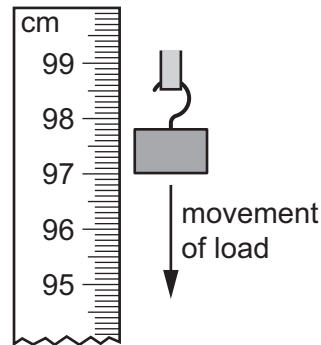

Fig. 3.3

Determine the extension of the plastic material 5 seconds after it is released.

Use measurements from Fig. 3.2 and Fig. 3.3.

Show your working.

extension = cm [2]



DO NOT WRITE IN THIS MARGIN



(c) Table 3.1 shows the student's results.

Table 3.1

time /s	0	5	10	30	50	70	90
extension /cm	0	3.6	5.7	6.1	6.8	6.8

Include, in Table 3.1, your value from (b) for the extension of the material after 5 s.

On the grid provided in Fig. 3.4, plot a graph of time on the x-axis against extension on the y-axis. Start your graph axes at (0, 0).

Draw the **curved** line of best fit through your points.

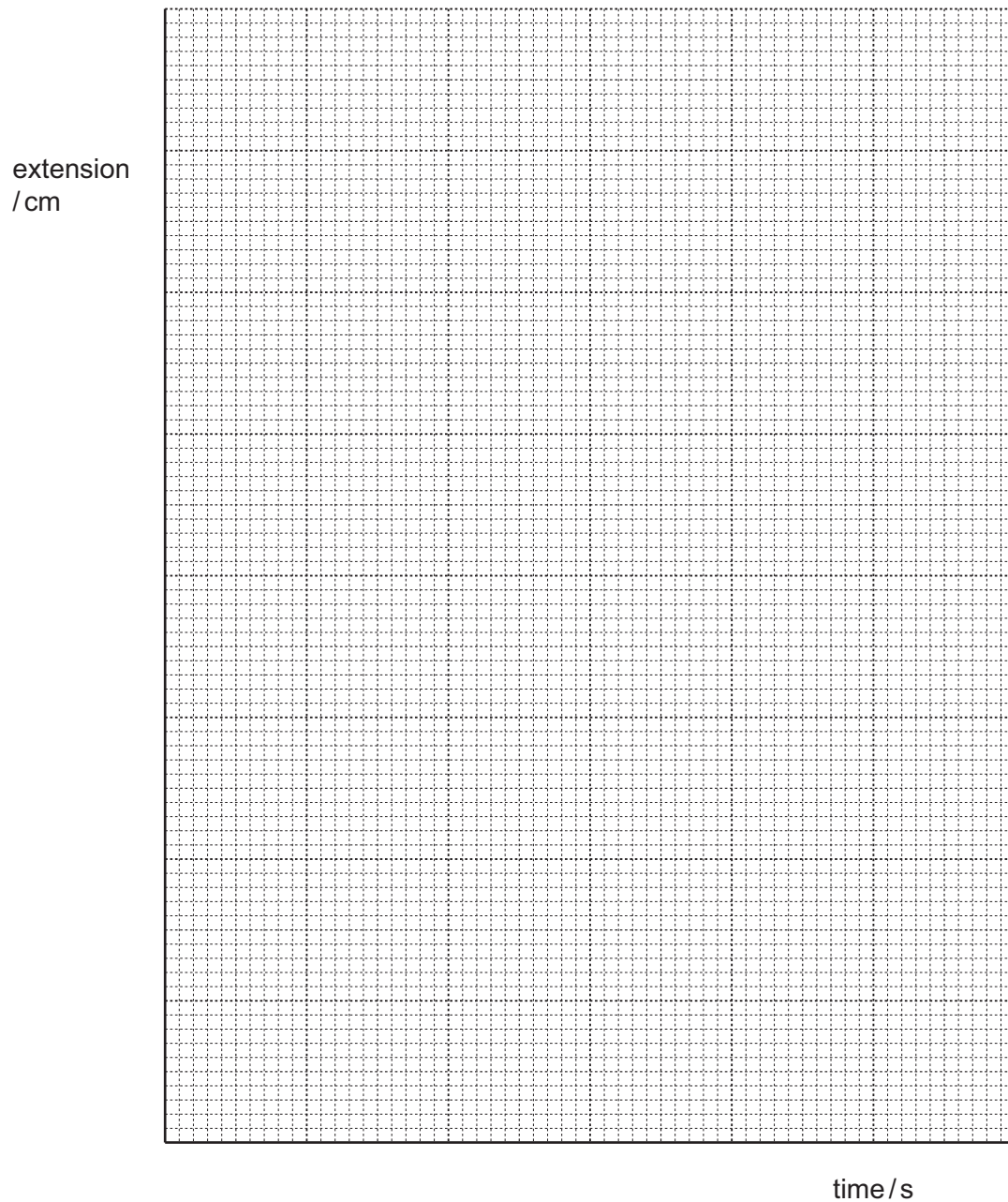

Fig. 3.4

[3]





(d) The arrangement of the apparatus in Fig. 3.1 and Fig. 3.2 minimises a possible error.

(i) State the name of the type of error that is minimised.

Explain how the arrangement minimises this error.

type of error

explanation

.....

[2]

(ii) Describe **one** additional source of error in the procedure described in (b).

.....

..... [1]

(iii) Describe **one** improvement that can be made to this experiment.

.....

..... [1]

[Total: 11]

DO NOT WRITE IN THIS MARGIN

DO NOT WRITE IN THIS MARGIN

DO NOT WRITE IN THIS MARGIN

DO NOT WRITE IN THIS MARGIN

DO NOT WRITE IN THIS MARGIN





4 When ammonium nitrate is dissolved in water, the temperature of the solution formed is lower than the starting temperature of the water.

A student states:

'The greater the mass of ammonium nitrate dissolved in the water, the more the temperature of the solution decreases.'

Plan an investigation to test whether the student's statement is correct.

You are provided with:

- solid ammonium nitrate
- distilled water
- any apparatus usually available in a school laboratory.

You are **not** provided with any other chemicals.

Include in your answer:

- a brief description of the method, including the apparatus you use
- the measurements you make
- the variables to keep constant and the variable to change
- how you use your results to draw a conclusion.

A diagram of apparatus and a results table are **not** required but you may include them if it helps to explain your plan.

.....

.....

.....





Handwriting practice area with horizontal dotted lines.



DO NOT WRITE IN THIS MARGIN



Notes for use in qualitative analysis

Tests for anions

anion	test	test result
carbonate, CO_3^{2-}	add dilute acid, then test for carbon dioxide gas	effervescence, carbon dioxide produced
chloride, Cl^- [in solution]	acidify with dilute nitric acid, then add aqueous silver nitrate	white ppt.
bromide, Br^- [in solution]	acidify with dilute nitric acid, then add aqueous silver nitrate	cream ppt.
iodide, I^- [in solution]	acidify with dilute nitric acid, then add aqueous silver nitrate	yellow ppt.
sulfate, SO_4^{2-} [in solution]	acidify with dilute nitric acid, then add aqueous barium nitrate	white ppt.

Tests for aqueous cations

cation	effect of aqueous sodium hydroxide	effect of aqueous ammonia
aluminium, Al^{3+}	white ppt., soluble in excess, giving a colourless solution	white ppt., insoluble in excess
ammonium, NH_4^+	ammonia produced on warming	–
calcium, Ca^{2+}	white ppt., insoluble in excess	no ppt. or very slight white ppt.
chromium(III), Cr^{3+}	green ppt., soluble in excess	green ppt., insoluble in excess
copper(II), Cu^{2+}	light blue ppt., insoluble in excess	light blue ppt., soluble in excess, giving a dark blue solution
iron(II), Fe^{2+}	green ppt., insoluble in excess, ppt. turns brown near surface on standing	green ppt., insoluble in excess, ppt. turns brown near surface on standing
iron(III), Fe^{3+}	red-brown ppt., insoluble in excess	red-brown ppt., insoluble in excess
zinc, Zn^{2+}	white ppt., soluble in excess, giving a colourless solution	white ppt., soluble in excess, giving a colourless solution





Tests for gases

gas	test and test result
ammonia, NH_3	turns damp red litmus paper blue
carbon dioxide, CO_2	turns limewater milky
chlorine, Cl_2	bleaches damp litmus paper
hydrogen, H_2	'pops' with a lighted splint
oxygen, O_2	relights a glowing splint

Flame tests for metal ions

metal ion	flame colour
lithium, Li^+	red
sodium, Na^+	yellow
potassium, K^+	lilac

Permission to reproduce items where third-party owned material protected by copyright is included has been sought and cleared where possible. Every reasonable effort has been made by the publisher (UCLES) to trace copyright holders, but if any items requiring clearance have unwittingly been included, the publisher will be pleased to make amends at the earliest possible opportunity.

To avoid the issue of disclosure of answer-related information to candidates, all copyright acknowledgements are reproduced online in the Cambridge Assessment International Education Copyright Acknowledgements Booklet. This is produced for each series of examinations and is freely available to download at www.cambridgeinternational.org after the live examination series.

Cambridge Assessment International Education is part of Cambridge Assessment. Cambridge Assessment is the brand name of the University of Cambridge Local Examinations Syndicate (UCLES), which is a department of the University of Cambridge.

