

---

**COMPUTER SCIENCE**

**9608/12**

Paper 1 Written Paper

**May/June 2019**

MARK SCHEME

Maximum Mark: 75

---

**Published**

This mark scheme is published as an aid to teachers and candidates, to indicate the requirements of the examination. It shows the basis on which Examiners were instructed to award marks. It does not indicate the details of the discussions that took place at an Examiners' meeting before marking began, which would have considered the acceptability of alternative answers.

Mark schemes should be read in conjunction with the question paper and the Principal Examiner Report for Teachers.

Cambridge International will not enter into discussions about these mark schemes.

Cambridge International is publishing the mark schemes for the May/June 2019 series for most Cambridge IGCSE™, Cambridge International A and AS Level and Cambridge Pre-U components, and some Cambridge O Level components.

---

This document consists of **11** printed pages.

**Generic Marking Principles**

These general marking principles must be applied by all examiners when marking candidate answers. They should be applied alongside the specific content of the mark scheme or generic level descriptors for a question. Each question paper and mark scheme will also comply with these marking principles.

**GENERIC MARKING PRINCIPLE 1:**

Marks must be awarded in line with:

- the specific content of the mark scheme or the generic level descriptors for the question
- the specific skills defined in the mark scheme or in the generic level descriptors for the question
- the standard of response required by a candidate as exemplified by the standardisation scripts.

**GENERIC MARKING PRINCIPLE 2:**

Marks awarded are always **whole marks** (not half marks, or other fractions).

**GENERIC MARKING PRINCIPLE 3:**

Marks must be awarded **positively**:

- marks are awarded for correct/valid answers, as defined in the mark scheme. However, credit is given for valid answers which go beyond the scope of the syllabus and mark scheme, referring to your Team Leader as appropriate
- marks are awarded when candidates clearly demonstrate what they know and can do
- marks are not deducted for errors
- marks are not deducted for omissions
- answers should only be judged on the quality of spelling, punctuation and grammar when these features are specifically assessed by the question as indicated by the mark scheme. The meaning, however, should be unambiguous.

**GENERIC MARKING PRINCIPLE 4:**

Rules must be applied consistently e.g. in situations where candidates have not followed instructions or in the application of generic level descriptors.

**GENERIC MARKING PRINCIPLE 5:**

Marks should be awarded using the full range of marks defined in the mark scheme for the question (however; the use of the full mark range may be limited according to the quality of the candidate responses seen).

**GENERIC MARKING PRINCIPLE 6:**

Marks awarded are based solely on the requirements as defined in the mark scheme. Marks should not be awarded with grade thresholds or grade descriptors in mind.

Question	Answer	Marks
1(a)(i)	<b>1 mark</b> for any valid example e.g. 192.168.0.1	<b>1</b>
1(a)(ii)	<b>1 mark</b> for correct answer  The number of IP addresses needed will exceed the number available using IPv4.	<b>1</b>
1(a)(iii)	<b>1 mark</b> per bullet point to <b>max 2</b>  <ul style="list-style-type: none"> <li>• Too many digits per group</li> <li>• Too many groups of digits</li> <li>• The address is more than 32 bits / 4 bytes</li> <li>• Colons are used as separators</li> </ul>	<b>2</b>
1(b)(i)	<b>1 mark</b> per bullet point to <b>max 2</b>  <ul style="list-style-type: none"> <li>• The PSTN consists of many different types of communication lines</li> <li>• Data is transmitted in both directions <u>at the same time</u> // (full) <u>duplex</u> data transmission</li> <li>• The communication passes through different switching centres</li> </ul>	<b>2</b>
1(b)(ii)	<b>1 mark</b> for benefit, <b>1 mark</b> for drawback  Benefit <ul style="list-style-type: none"> <li>• (Probably) faster connection / communication / transmission of data</li> <li>• (Usually) more consistent transmission speed</li> <li>• Improved security</li> </ul> Drawback <ul style="list-style-type: none"> <li>• Expensive to <u>set-up / maintain</u></li> <li>• Disruption to the dedicated line would leave no alternative</li> </ul>	<b>2</b>

Question	Answer	Marks
1(c)	<p><b>1 mark</b> per bullet point to <b>max 4</b>, <b>max 3 for router</b>, <b>max 3 for gateway</b> Only award the repeated bullet points (1 to 5 in each section) once</p> <p>Router:</p> <ul style="list-style-type: none"> <li>• Connects two (or more) networks</li> <li>• Can connect a network to a WAN // acts as the single access point for...</li> <li>• Receives packets and forwards towards the destination</li> <li>• ...using the IP address of the destination</li> <li>• Assigns private IP addresses</li> <li>• Operates between <u>similar</u> networks // networks using the <u>same protocol</u></li> <li>• Can be used to segment a network</li> </ul> <p>Gateway:</p> <ul style="list-style-type: none"> <li>• Connect two (or more) networks</li> <li>• Can connect a network to a WAN // acts as the single access point for...</li> <li>• Receives packets and send packets towards the destination</li> <li>• ...using the IP address of the destination</li> <li>• Assigns private IP addresses</li> <li>• Connects two <u>dissimilar</u> networks // networks that use <u>different protocols</u></li> </ul>	<b>4</b>
1(d)	<p><b>1 mark</b> per bullet point to <b>max 3</b> for any valid answer</p> <p>For example:</p> <ul style="list-style-type: none"> <li>• File server</li> <li>• Print server</li> <li>• Proxy server</li> <li>• Web server</li> <li>• Application server</li> </ul>	<b>3</b>

Question	Answer	Marks
2(a)(i)	<p><b>1 mark</b> for correct answer</p> <ul style="list-style-type: none"> <li>• To convert a (higher level) programming language to a different form</li> </ul>	<b>1</b>
2(a)(ii)	<p><b>1 mark</b> per bullet point to <b>max 2</b></p> <ul style="list-style-type: none"> <li>• Easier de-bugging</li> <li>• ...because errors can be corrected in real time</li> <li>• The effect of any change made to the code can be seen immediately</li> <li>• Parts of the program can be <u>tested</u>, without all the program code being available</li> </ul>	<b>2</b>
2(a)(iii)	<p><b>1 mark</b> for correct answer</p> <p>Assembler</p>	<b>1</b>

Question	Answer	Marks
2(b)	<p><b>1 mark</b> per bullet point to <b>max 2</b></p> <ul style="list-style-type: none"> <li>• The code is already written so the programmer is not starting over again which saves time</li> <li>• The code will have been used by many people so it should be already thoroughly tested and relatively error-free / won't need re-testing</li> <li>• The programmer can use e.g. mathematical / graphics functions etc. that he may not know how to code</li> <li>• Use of named library functions can simplify the program and make it easier to read</li> <li>• The library routine code should conform to industry standards and therefore contribute towards a more robust program</li> </ul>	<b>2</b>

Question	Answer	Marks
3(a)	<p><b>1 mark</b> for each error <b>and</b> correction</p> <ul style="list-style-type: none"> <li>• Line 02 should be +1 not -1 // <math>PC \leftarrow [PC] + 1</math></li> <li>• Line 03 should be double brackets around MAR // <math>MDR \leftarrow [[MAR]]</math></li> <li>• Line 04 should be MDR not MAR // <math>CIR \leftarrow [MDR]</math></li> </ul>	<b>3</b>
3(b)	<p><b>1 mark</b> for each group to <b>max. 2</b></p> <ul style="list-style-type: none"> <li>• Data movement</li> <li>• Arithmetic operations</li> <li>• (Unconditional and conditional) jump instructions</li> <li>• Compare instructions</li> <li>• Modes of addressing</li> </ul>	<b>2</b>
3(c)	<p><b>1 mark</b> per bullet</p> <ul style="list-style-type: none"> <li>• Storing 0 in 401 (line 51)</li> <li>• Loading memory location 300, value 2 to ACC (line 52)</li> <li>• Adding 64 to ACC to give 66 (line 55)</li> <li>• Outputting B (line 56)</li> <li>• Load 0 (line 57), increment ACC (line 58) and store 1 in 401 (line 59)</li> <li>• Incrementing IX (line 60)</li> <li>• Loading 5 (line 52), adding 64 (line 55), outputting E (line 56) loading 1 (line 57), incrementing ACC (line 58), storing 2 in 401 (line 59) and incrementing IX (line 60)</li> <li>• Load 0 (line 52) <u>and end</u></li> </ul>	<b>8</b>

Instruction address	ACC	Memory address						IX	OUTPUT	
		300	301	302	303	400	401			
		2	5	0	4	64		0		
50	0									
51							0			[1]
52	2									[1]
53										
54										
55	66									[1]
56									B	[1]
57	0									[1]
58	1									
59							1			
60								1		[1]
61										[1]
52	5									
53										
54										
55	69									
56									E	
57	1									
58	2									
59							2			
60								2		
61										
52	0									[1]
53										
54										
62										

Question	Answer	Marks
3(d)(i)	<b>1 mark</b> for correct answer  0100 0001	<b>1</b>
3(d)(ii)	<b>1 mark</b> for correct answer  41	<b>1</b>
3(d)(iii)	<b>1 mark</b> for correct answer  0044	<b>1</b>

Question	Answer	Marks
4(a)(i)	<b>1 mark</b> per bullet point to <b>max 3</b> <ul style="list-style-type: none"> <li>• The microphone has a diaphragm / ribbon (accept equivalent)</li> <li>• The incoming sound <u>waves</u> cause vibrations (of the diaphragm)</li> <li>• ...causing a coil to move past a magnet (dynamic microphone) // changing the capacitance (condenser microphone) // deforms the crystal (crystal microphone) etc.</li> <li>• An electrical signal is produced</li> </ul>	<b>3</b>
4(a)(ii)	<b>1 mark</b> per bullet to <b>max 3</b> <ul style="list-style-type: none"> <li>• The revolving drum is initially given an electrical charge</li> <li>• A laser beam (bounces off moving mirrors) <u>scans back and forth</u> across the drum</li> <li>• ...discharging certain points (i.e. 'drawing' the letters and images to be printed as a pattern of electrical charges)</li> <li>• The drum is coated with oppositely charged toner (which only sticks to charged areas)</li> <li>• The drum rolls over electro-statically <u>charged</u> paper // Electro-statically <u>charged</u> paper is fed (towards the drum)</li> <li>• The 'pattern' on the drum is transferred to the paper</li> <li>• The paper is passed through the fuser to seal the image</li> <li>• The electrical charge is removed from the drum // the excess toner is collected</li> </ul>	<b>3</b>
4(b)	<b>1 mark</b> per bullet to <b>max 2</b> <ul style="list-style-type: none"> <li>• Stores all the scan lines for an entire frame // displays / records all the frame data at the same time // not split into fields</li> <li>• Complete frames are displayed <u>in sequence</u></li> <li>• The rate of picture display is the same as the frame rate.</li> </ul>	<b>2</b>

Question	Answer	Marks
4(c)	<p><b>1 mark per bullet to max 4</b></p> <ul style="list-style-type: none"> <li>• DRAM has to be refreshed / charged and SRAM does not require a refresh</li> <li>• DRAM uses a single transistor and capacitor and SRAM uses more than one transistor</li> <li>• DRAM stores each bit as a charge and in SRAM each bit is stored using a flip-flop/latch</li> <li>• DRAM requires higher power consumption under low levels of access, (which is significant when used in battery-powered devices because it requires more circuitry for refreshing) // SRAM uses less power (no need to refresh)</li> <li>• DRAM less expensive to purchase (requires fewer transistors) // SRAM is more expensive to buy (as it requires more transistors)</li> <li>• DRAM has slower <u>access</u> time/speed (because it needs to be refreshed) // SRAM has faster <u>access</u> times</li> <li>• DRAM can have higher storage/bit/data <u>density</u> // SRAM has lower storage/bit/data <u>density</u></li> <li>• DRAM used in main memory and SRAM used in cache memory</li> </ul>	<b>4</b>
4(d)(i)	<p><b>1 mark</b> for correct answer</p> <p>Formal or legal recognition of ownership of the program // Formal or legal restriction / permissions on use of the program // The intellectual property rights to the program</p>	<b>1</b>
4(d)(ii)	<p><b>1 mark</b> per bullet point</p> <ul style="list-style-type: none"> <li>• She does not wish to release the source <u>code</u></li> <li>• She does not want anyone to be able to edit / modify / share the source code/program</li> <li>• She wants to make money from the program</li> </ul>	<b>2</b>



Question	Answer	Marks
4(d)(iii)	<p><b>1 mark</b> for a <u>name and a description</u> of each licence to <b>max 2</b></p> <p>Commercial Software</p> <ul style="list-style-type: none"> <li>• The program is purchased for a fee</li> <li>• It restricts the number of users/possible time period for use // Limited number of installations allowed // Software key needed to install</li> <li>• Source code not provided // source code protected / cannot be edited</li> <li>• Anyone can purchase/download if agree to the terms</li> </ul> <p>Shareware</p> <ul style="list-style-type: none"> <li>• The program is free for a trial period // The (free) program may have limited functionality // Need to purchase / enter details after trial</li> <li>• Users do not have access to the source code // source code may not be edited</li> <li>• Users may re-distribute the software.</li> </ul> <p>Freeware</p> <ul style="list-style-type: none"> <li>• There is no charge for the software</li> <li>• The software could still be copyrighted</li> <li>• She can set her own restrictions on what a user can do with the program</li> </ul>	<b>2</b>

Question	Answer	Marks
5(a)(i)	<p><b>1 mark</b> for correct answer</p> <p><u>Repeated</u> / <u>duplicated</u> data</p>	<b>1</b>
5(a)(ii)	<p><b>1 mark</b> per bullet point</p> <ul style="list-style-type: none"> <li>• Because each record/piece of data is stored once <u>and</u> is referenced by a (primary) key</li> <li>• Because data is stored in individual tables</li> <li>• ...and the tables are linked by relationships</li> <li>• By the proper use of Primary and Foreign keys</li> <li>• By enforcing referential integrity</li> <li>• By going through the normalisation process</li> </ul>	<b>3</b>
5(b)(i)	<p><b>1 mark</b> per bullet point</p> <ul style="list-style-type: none"> <li>• Security ensures that data is safe from unauthorised access // safe from loss</li> <li>• Integrity ensures that data is accurate / consistent / up to date</li> </ul>	<b>2</b>

Question	Answer	Marks
5(b)(ii)	<p><b>1 mark</b> for naming, <b>1 mark</b> for description</p> <p>For example:</p> <ul style="list-style-type: none"> <li>• Access rights // User accounts</li> <li>• Restrict actions (e.g. read / read-write) of specific users // unauthorised users cannot access the database</li> <li>• Views</li> <li>• Restrict which parts of the database specific users can see</li> <li>• Password // Biometrics // PIN code</li> <li>• Prevents unauthorised access</li> <li>• Automatic Backup</li> <li>• Create regular copies of data in case of loss</li> <li>• Encryption</li> <li>• Data is incomprehensible to unauthorised users</li> </ul>	<b>4</b>
5(b)(iii)	<p><b>1 mark</b> per bullet</p> <ul style="list-style-type: none"> <li>• Query Processor</li> <li>• Developer Interface</li> </ul>	<b>2</b>

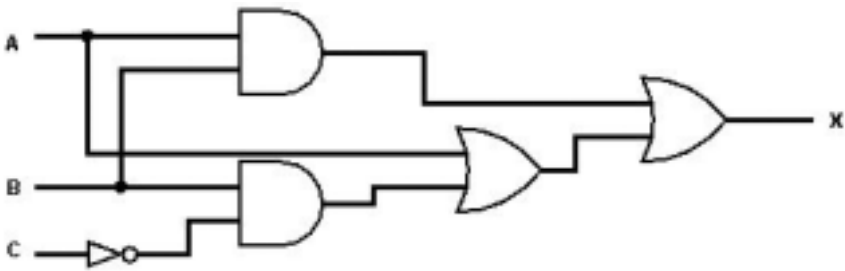
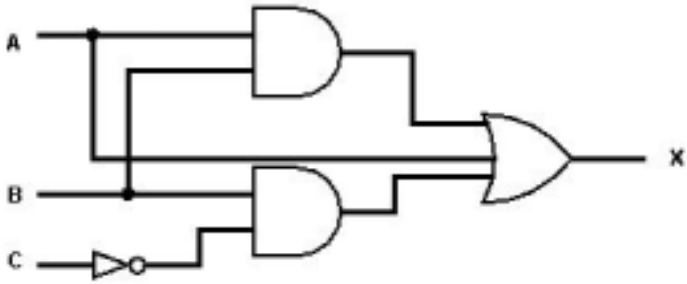
Question	Answer	Marks
6(a)	<p><b>1 mark</b> per gate      The OR gates may be re-sequenced</p>  <p>Alternatively: 3-input OR gate  <b>1 mark</b> for first three gates, and <b>2 marks</b> for 3-input OR gate</p> 	<b>5</b>

Question	Answer					Marks																																													
6(b)	<b>1 mark</b> for each pair of rows (shaded)					<b>4</b>																																													
<table border="1" style="width: 100%; border-collapse: collapse;"> <thead> <tr> <th style="width: 12.5%; text-align: center;">A</th> <th style="width: 12.5%; text-align: center;">B</th> <th style="width: 12.5%; text-align: center;">C</th> <th style="width: 45%; text-align: center;">Working Space</th> <th style="width: 12.5%; text-align: center;">X</th> </tr> </thead> <tbody> <tr> <td style="text-align: center;">0</td> <td style="text-align: center;">0</td> <td style="text-align: center;">0</td> <td></td> <td style="text-align: center;">0</td> </tr> <tr> <td style="text-align: center;">0</td> <td style="text-align: center;">0</td> <td style="text-align: center;">1</td> <td></td> <td style="text-align: center;">0</td> </tr> <tr style="background-color: #cccccc;"> <td style="text-align: center;">0</td> <td style="text-align: center;">1</td> <td style="text-align: center;">0</td> <td></td> <td style="text-align: center;">1</td> </tr> <tr style="background-color: #cccccc;"> <td style="text-align: center;">0</td> <td style="text-align: center;">1</td> <td style="text-align: center;">1</td> <td></td> <td style="text-align: center;">0</td> </tr> <tr> <td style="text-align: center;">1</td> <td style="text-align: center;">0</td> <td style="text-align: center;">0</td> <td></td> <td style="text-align: center;">1</td> </tr> <tr> <td style="text-align: center;">1</td> <td style="text-align: center;">0</td> <td style="text-align: center;">1</td> <td></td> <td style="text-align: center;">1</td> </tr> <tr style="background-color: #cccccc;"> <td style="text-align: center;">1</td> <td style="text-align: center;">1</td> <td style="text-align: center;">0</td> <td></td> <td style="text-align: center;">1</td> </tr> <tr style="background-color: #cccccc;"> <td style="text-align: center;">1</td> <td style="text-align: center;">1</td> <td style="text-align: center;">1</td> <td></td> <td style="text-align: center;">1</td> </tr> </tbody> </table>							A	B	C	Working Space	X	0	0	0		0	0	0	1		0	0	1	0		1	0	1	1		0	1	0	0		1	1	0	1		1	1	1	0		1	1	1	1		1
A	B	C	Working Space	X																																															
0	0	0		0																																															
0	0	1		0																																															
0	1	0		1																																															
0	1	1		0																																															
1	0	0		1																																															
1	0	1		1																																															
1	1	0		1																																															
1	1	1		1																																															