



UNIVERSITY OF CAMBRIDGE INTERNATIONAL EXAMINATIONS  
General Certificate of Education  
Advanced Subsidiary Level and Advanced Level

CANDIDATE  
NAME

CENTRE  
NUMBER

--	--	--	--	--

CANDIDATE  
NUMBER

--	--	--	--

\* 0 2 5 1 7 2 3 4 1 0 \*

**COMPUTING**

**9691/13**

Paper 1

**May/June 2012**

**1 hour 30 minutes**

Candidates answer on the Question Paper.

No additional materials are required.

No calculators allowed.

**READ THESE INSTRUCTIONS FIRST**

Write your Centre number, candidate number and name on all the work you hand in.

Write in dark blue or black pen.

You may use a soft pencil for any diagrams, graphs or rough working.

Do not use staples, paper clips, highlighters, glue or correction fluid.

**DO NOT WRITE IN ANY BARCODES.**

Answer **all** questions.

No marks will be awarded for using brand names for software packages or hardware.

At the end of the examination, fasten all your work securely together.

The number of marks is given in brackets [ ] at the end of each question or part question.

This document consists of **12** printed pages.



1 (a) (i) Give **two** differences between ROM (Read Only Memory) and RAM (Random Access Memory).

.....  
.....  
.....  
..... [2]

(ii) State why user files currently being used are stored in RAM.

.....  
..... [1]

(iii) State **two** types of software which would be found in RAM.

.....  
.....  
.....  
..... [2]

(b) Describe the purpose of having a peripheral storage device as part of a computer system.

.....  
.....  
.....  
..... [2]



2 (a) Define the following types of software:

(i) operating system

.....  
..... [1]

(ii) generic applications software

.....  
..... [1]

(b) (i) Distinguish between custom-written software and off-the-shelf software.

.....  
.....  
.....  
..... [2]

(ii) State the advantages and disadvantages of using custom-written software.

.....  
.....  
.....  
.....  
.....  
.....  
.....  
.....  
..... [4]

(c) A group of salesmen wish to set up a stall in a shopping mall advertising new appliances. They intend to take details of potential customers so that they can then contact them later in their own homes.

Explain what the salesmen could use the following types of software for:

(i) drawing package

.....  
..... [1]

(ii) database

.....  
..... [1]

(iii) presentation software

.....  
..... [1]

(d) The salesmen each have a terminal on the stall in the mall and each terminal is connected to a single computer. The computer runs a multi-user operating system. Describe what is meant by a multi-user operating system and explain how the system works.

.....  
.....  
.....  
.....  
.....  
.....  
.....  
.....  
..... [4]

3 (i) State what is meant by a batch-processing operating system.

.....  
..... [1]

(ii) Describe an application which needs to be batch processed.

.....  
..... [1]

(iii) Explain why your choice needs to be a batch application.

.....  
.....  
.....  
..... [2]

4 When data is to be entered into a computer system it is sometimes entered using manual methods and sometimes it is captured and entered automatically. Describe the following methods of entering data into a computer system automatically. In each case give an example of where it would be used.

(i) Barcode reading

.....  
.....  
.....  
.....  
.....  
..... [3]

(ii) Magnetic stripe card reading

.....  
.....  
.....  
.....  
..... [3]







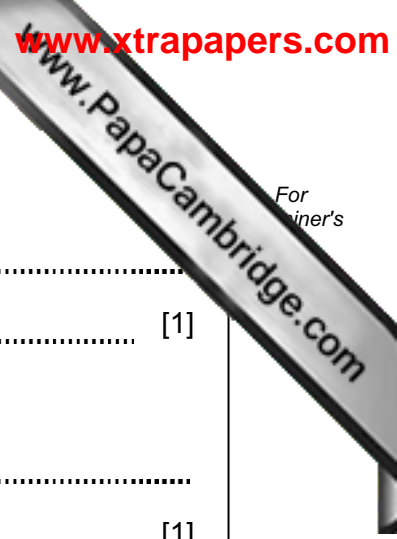

7 (a) (i) Change the denary integer 222 into a binary number, using 10 bits.

.....  
..... [1]

(ii) Change the binary number 01101100 into a positive denary integer.

.....  
..... [1]

(b) A stock control system stores data about T-shirts on sale in a shop. The program which uses this data declares the following variables and data types:

**ItemName** as a **String**  
**ItemSize** as a **Character**  
**SellByDate** as a **Date**

(i) "Olympics 2012" would be an appropriate value to be stored in **ItemName**.  
Give a value appropriate to each of the other two variables:

**ItemSize** .....

**SellByDate** ..... [2]

(ii) The table shows three fields that are used in the records for data stored about T-shirts.  
Give the data type for each field. Give a reason for your choice in each case.

Field name	Data type	Reason
<b>SupplierName</b>		
<b>MinimumStockLevel</b>		
<b>Price</b>		

[6]

8 (a) A firm has offices in the three major cities in a country. The manager is advised that Local Area Networks (LANs) in each of the cities should be connected to provide a Wide Area Network (WAN).

(i) Explain to the manager what is meant by a WAN.

.....  
.....  
.....  
..... [2]

(ii) Communication across a LAN is by serial data transmission. Explain what is meant by serial data transmission.

.....  
.....  
.....  
..... [2]

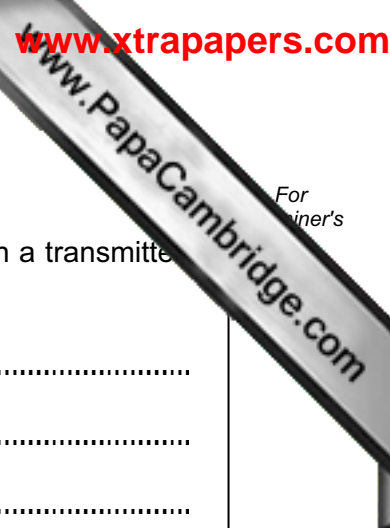

(b) When data is transmitted it may become corrupted.

(i) Explain how a parity check can be used to detect a possible error in a transmitted byte.

.....

.....

.....

.....

.....

.....

..... [3]

(ii) Describe how parity can be used to identify and correct the single error in this transmitted data block:

0	1	1	0	1	1	0	1
1	0	0	1	0	1	1	1
0	1	0	1	0	1	0	0
1	0	0	0	1	0	0	1
0	1	1	0	0	0	1	1
1	0	0	0	0	1	1	0
0	1	1	0	1	1	0	1
0	1	0	0	0	0	0	0

Parity byte

.....

.....

.....

.....

.....

..... [3]

9 (a) Complete the truth table to show the output from the logic gate shown.

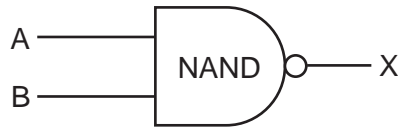

A	B	X
0	0	
0	1	
1	0	
1	1	

[2]

(b) Complete the truth table to show the outputs from the logic circuit shown.

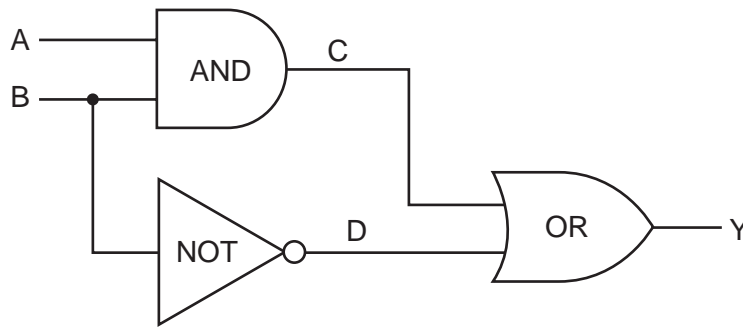

A	B	C	D	Y
0	0			
0	1			
1	0			
1	1			

[4]