



UNIVERSITY OF CAMBRIDGE INTERNATIONAL EXAMINATIONS
General Certificate of Education
Advanced Subsidiary Level and Advanced Level

DESIGN AND TECHNOLOGY

9705/01

Paper 1

October/November 2007

3 hours

Additional Materials: Answer Booklet/Paper
A3 Drawing paper (3 sheets)
A range of design drawing equipment



READ THESE INSTRUCTIONS FIRST

If you have been given an Answer Booklet, follow the instructions on the front cover of the Booklet.
Write your answers and working on the separate Answer Booklet/Paper provided.
Write your name, Centre number and candidate number on all the work you hand in.
Write in dark blue or black pen.
You may use a soft pencil, or coloured pencils/pens as appropriate, for any diagrams, graphs or rough working.
Do not use staples, paper clips, highlighters, glue or correction fluid.
DO NOT WRITE ON ANY BARCODES.

Section A
Answer **one** question.

Section B
Answer **one** question.

Section C
Answer **one** question on plain A3 paper.

You are advised to spend **30 minutes** on each of Sections A and B and **2 hours** on Section C.
At the end of the examination, fasten all your work securely together.
The number of marks is given in brackets [] at the end of each question or part question.
All dimensions are in millimetres.

This document consists of **10** printed pages and **2** blank pages.



Section A

Answer **one** question from this section.

- 1 Fig. 1 shows a balancing toy which is to be made in a school workshop.

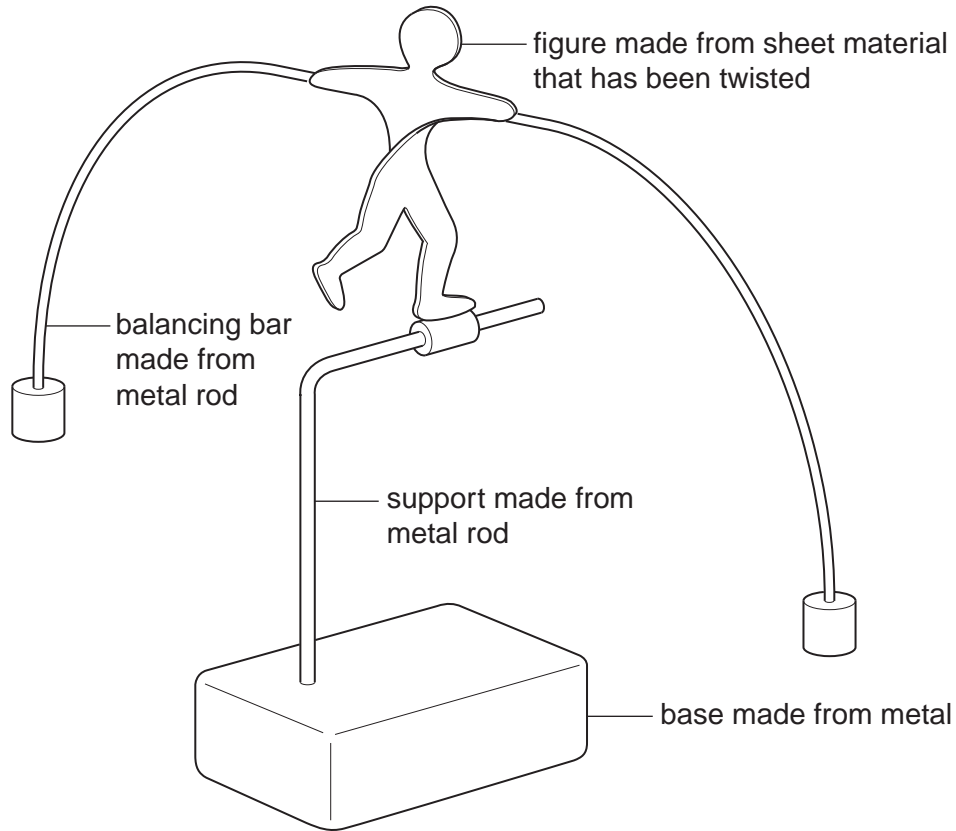

Fig. 1

- (a) Name a suitable sheet material for making the figure and give **one** reason for your choice. [2]
- (b) Use notes and sketches to describe:
- (i) how the figure would be cut out and finished to the required shape; [6]
 - (ii) how the balancing bar could be attached to the figure so that it could be easily removed; [6]
 - (iii) how a thread would be made on the end of the support so that it could be screwed into the base. [6]

You must give details about the tools, equipment and processes involved and the safety precautions that have to be taken at each stage.

2 Fig. 2 shows a wooden box which is to be made in a school workshop. The box has a sliding top.

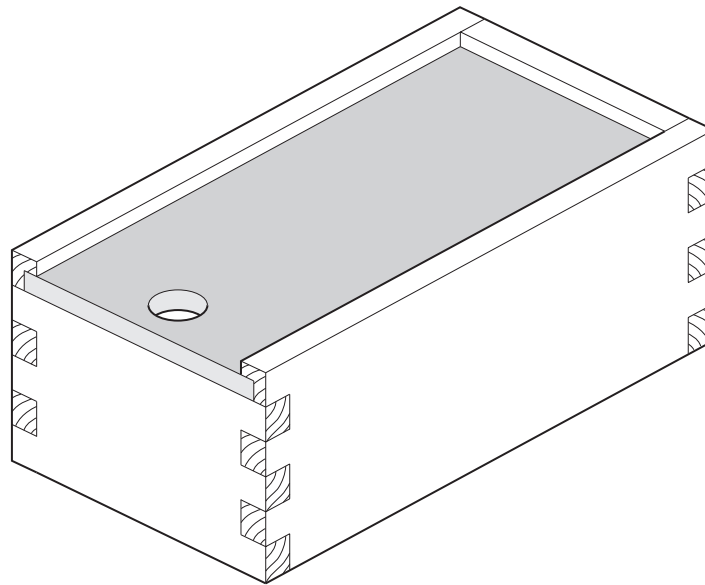

Fig. 2

- (a) Name a suitable sheet material for making the sliding top and give **one** reason for your choice. [2]
- (b) Use notes and sketches to describe:
 - (i) how the comb joint would be marked out for one of the corners; [6]
 - (ii) how the comb joint would be made; [6]
 - (iii) how the groove around the top of the box, which the top slides in, would be made. [6]

You must give details about the tools, equipment and processes involved and the safety precautions that have to be taken at each stage.

4

3 Fig. 3 shows the packaging for a mobile phone.

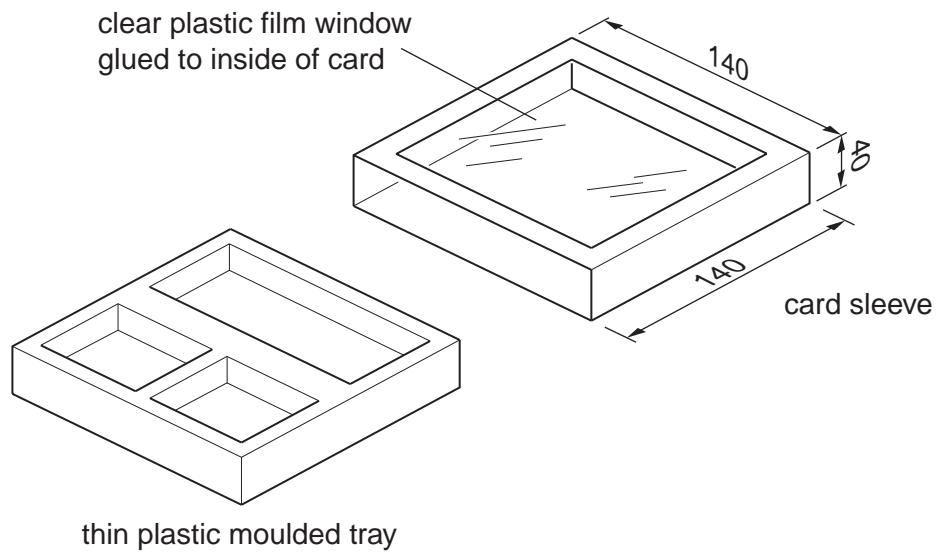

Fig. 3

- (a) Name a suitable card for making the sleeve and give **one** reason for your choice. [2]
- (b) Sketch, to an appropriate scale, the development (net) required to make the card sleeve. [4]
- (c) Use notes and sketches to describe how the development (net) of the card sleeve could be drawn using CAD (computer aided design). [7]

You must give details about the equipment, including software, and processes required to produce the drawing.

- (d) Use notes and sketches to describe how the plastic moulded tray would be made using vacuum forming. [7]

You must give details about the tools, equipment and processes involved and the safety precautions that have to be taken at each stage.

5

Section B

Answer **one** question from this section.

- 4 A range of desk lamp designs is shown in Fig. 4.

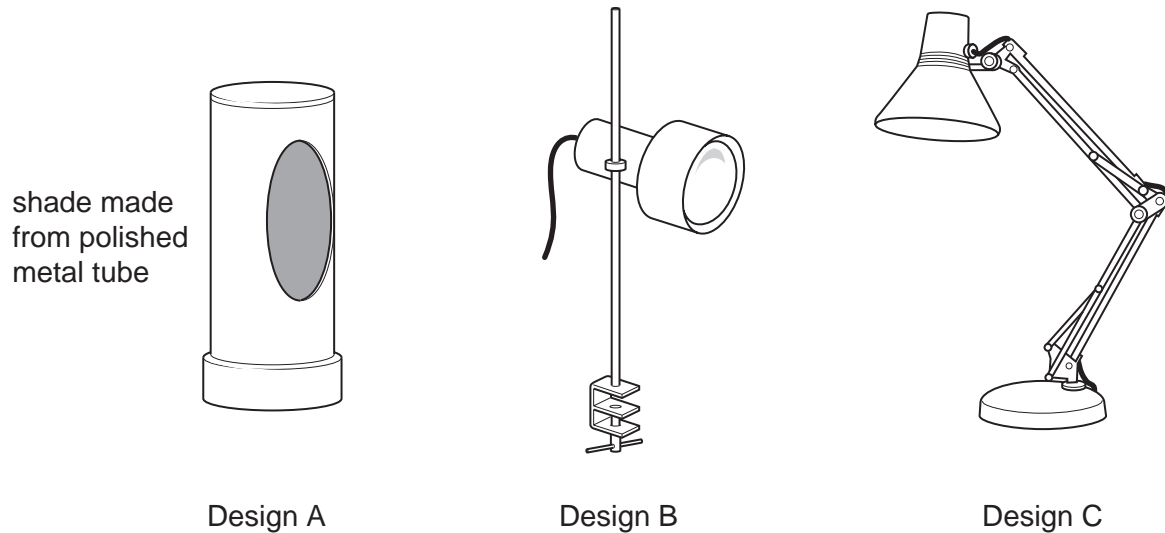

Fig. 4

- (a) Explain why there is a label on most desk lamps which specifies a maximum wattage for the bulb that should be used. [2]
- (b) The shade in Design A is made from metal tube.
Describe **two** problems, related to safety, that could occur when metal is used for light shades. [4]
- (c) Explain how the two problems that you have identified in (b) could be overcome. [6]
- (d) Discuss the suitability of the three designs for use as desk lamps.

Your answer should:

- (i) analyse the situation and identify three relevant issues/points raised by the question; [3]
- (ii) explain why you consider these three issues/points to be relevant; [3]
- (iii) use a specific example/evidence to support your answer. [2]

- 5 The mechanism used in the bicycle brake shown in Fig. 5 is based on a bell crank. The lever pulls the cable which causes the two brake arms to move towards each other simultaneously. This action brings the two pads into contact with the braking surface of the wheel rim. Springs return the arms to move back when the lever is released.

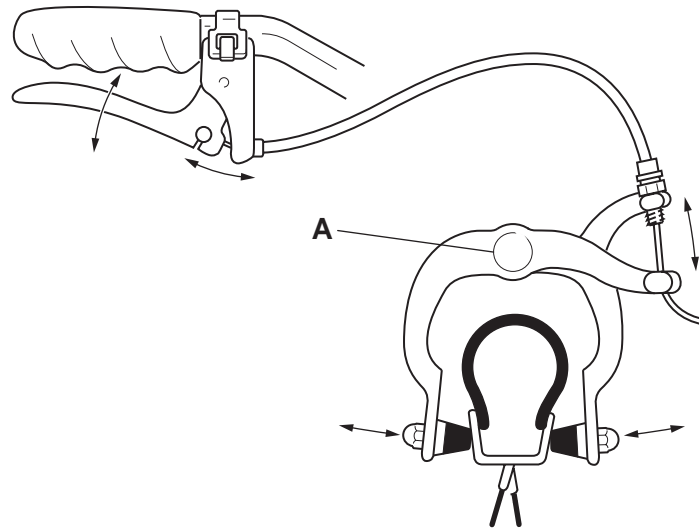

Fig. 5

- (a) Explain the function of the design feature shown at **A**. [2]
- (b) Describe **two** problems that could occur with the brakes when they have been used for a long time. [4]
- (c) Explain how the design of the brake allows the two problems you have identified in (b) to be overcome. [6]

Fig. 6 shows a mountain bike.



- Mudguards (available as an optional extra) made from flexible thermoplastic.
- Frame made from steel tube.
- Gel padded saddle with vinyl cover.
- Wheels have aluminium rims with stainless steel spokes.
- Kevlar reinforced rubber tyres.

Fig. 6

(d) Discuss the factors involved in the choice of materials for the mountain bike.

Your answer should:

- (i) analyse the situation and identify three relevant issues/points raised by the question; [1]
- (ii) explain why you consider the three issues/points to be relevant; [3]
- (iii) use a specific example/evidence to support your answer. [2]

6 Fig. 7 shows a box to hold chocolates.

The box is made from re-cycled card.

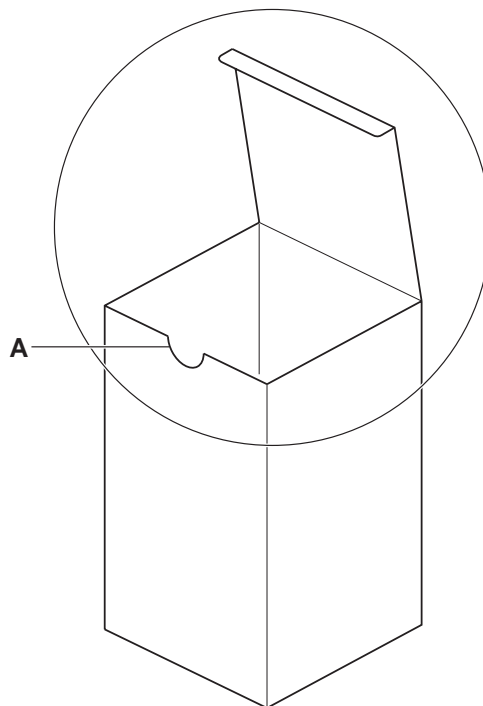

Fig. 7

- (a) Explain the function of the design feature shown at A. [2]
- (b) Describe **two** problems with the design of the top section of the box that has been circled in Fig. 7. [4]
- (c) Explain how the two problems that you have identified in (b) could be overcome. [6]
- (d) Discuss how health and safety issues are addressed when using re-cycled card to package food products.

Your answer should:

- (i) analyse the situation and identify three relevant issues/points raised by the question; [3]
- (ii) explain why you consider the three issues/points to be relevant; [3]
- (iii) use a specific example/evidence to support your answer. [2]

8

Section C

Answer **one** question from this section.

You should use one side of A3 plain paper for **each** of the five parts (a) – (e) of the question you choose to answer.

Where you are asked to **develop** an idea you must show, using bold sketches and notes, the development, reasoning and composition of a range of ideas into a single design proposal. You must give details about materials, construction and other relevant technical aspects.

- 7 Fig. 8 shows an incomplete idea for a child's wooden go-cart. It is to be steered by pivoting the front axle beam as shown. The wheels have a 12 mm hole in their centre.

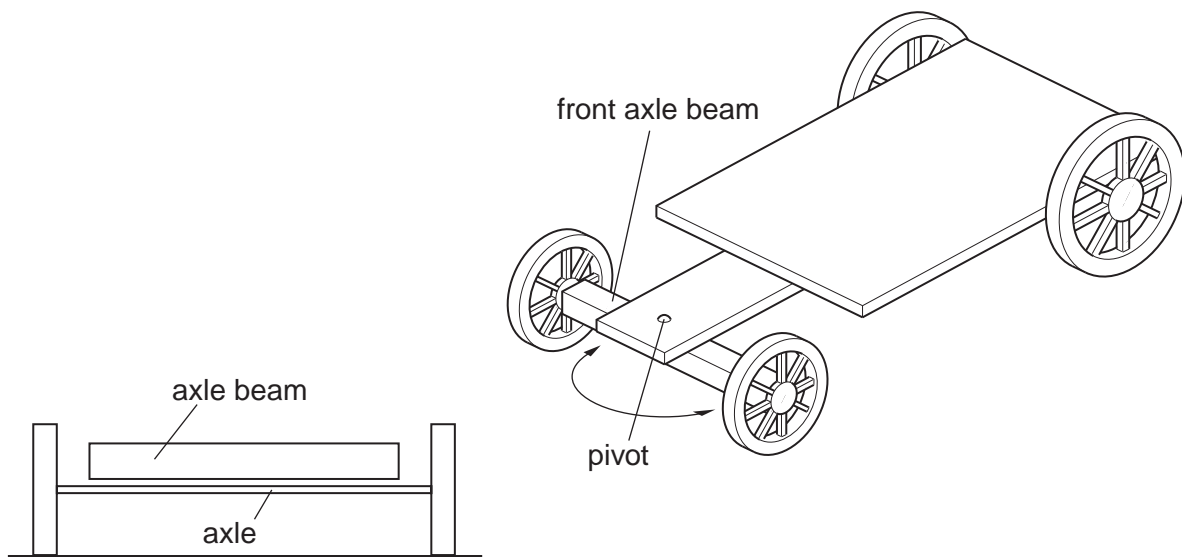

Fig. 8

- (a) Using notes and sketches, **develop** the idea to show a design feature that will attach the axle beam to the go-cart allowing it to pivot as required. [16]
- (b) Using notes and sketches, **develop** the idea to show design features which attach the wheels to the axle and the axle to the axle beam. [16]
- (c) Using notes and sketches, **develop** a design for a seat for the go-cart. [16]
- (d) Using notes and sketches, **develop** a design for a braking system for the go-cart. [16]
- (e) Produce a pictorial rendered drawing of the complete go-cart which shows all of the features that you have designed in (a) – (d). [16]

8 Fig. 9 shows an incomplete idea for a piece of packaging which is to hold ten of the glasses shown.

The packaging is to be made from card and clear plastic film.

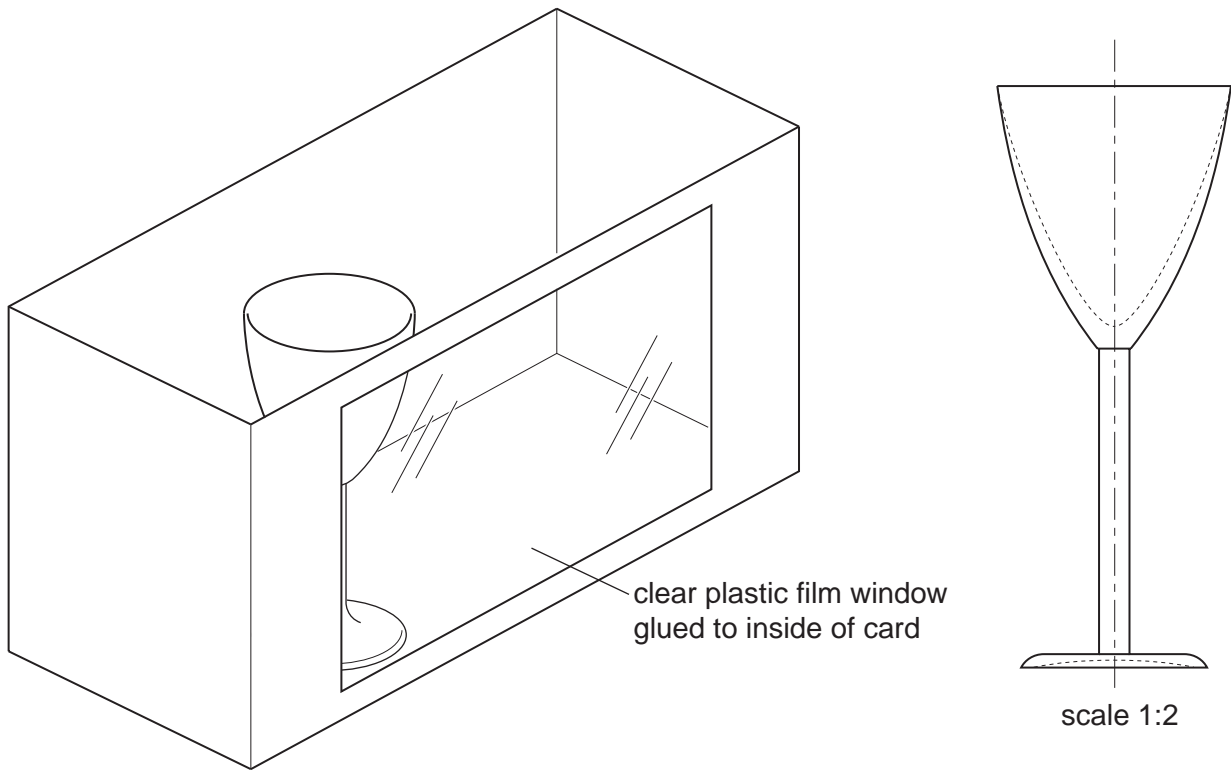

Fig. 9

- (a) Using notes and sketches, **develop** the idea to show a design feature that will separate each glass in the packaging and prevent them from breaking. [16]
- (b) Using notes and sketches, **develop** the idea to show a top for the packaging which incorporates a carrying handle that folds flat when not in use. [16]
- (c) Using notes and sketches, **develop** a design for a symbol to go on the packaging which indicates the contents are breakable.

Details must be given about the method that would be used to print the symbol onto the packaging. [16]

- (d) Sketch, to an appropriate scale, the development/s (net/s) required to make the complete packaging. Clearly show all fold lines, glue tabs and other fixing methods used. [16]
- (e) Produce a pictorial rendered drawing of the complete packaging which shows all of the features that you have designed in (a) – (c). [16]

9 Fig. 10 shows an incomplete idea for a child's mechanical digger to be used in a sandpit. Most of the digger is made from metal. The levers enable a child to raise and lower the scoop, fill it with sand and tip the sand out.

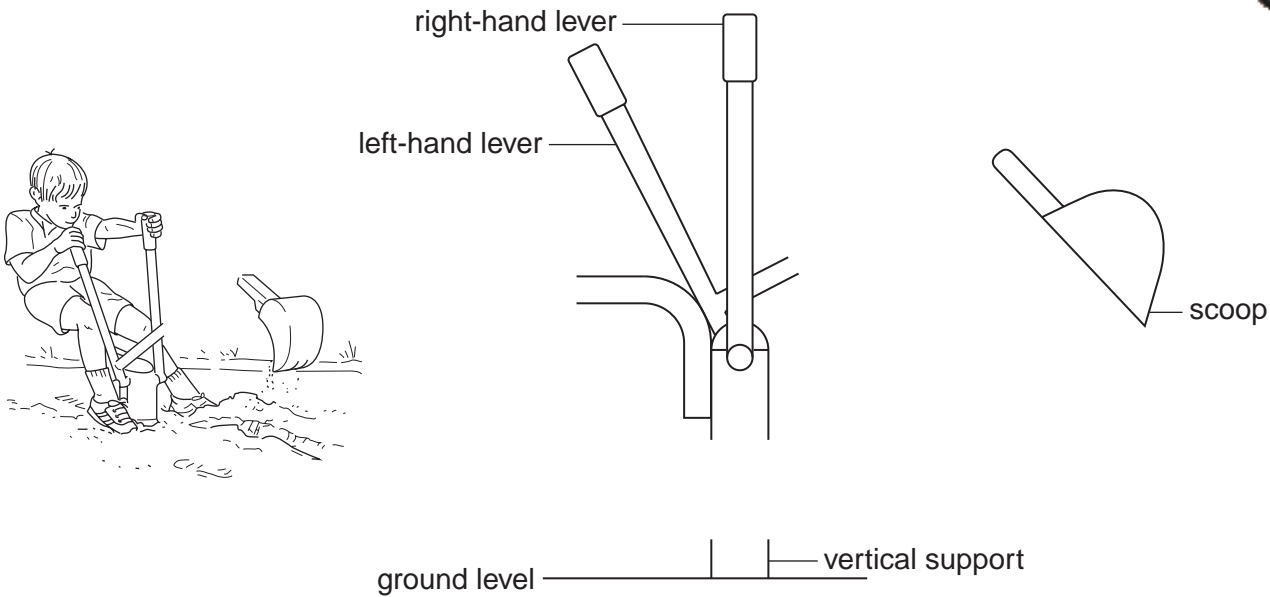

Fig. 10

- (a) Using notes and sketches, **develop** the idea to show a method of joining the digger to the vertical support which would allow the digger to rotate. [16]
- (b) Using notes and sketches, **develop** the idea to show how the levers would be connected to the scoop and how the levers operate the scoop. On your solution label the pivot points and use arrows to indicate how the mechanisms work. [16]
- (c) Using notes and sketches, **develop** a design for a seat for the digger. [16]
- (d) Using notes and sketches, **develop** a design for the handles so that they are more ergonomic and comfortable to use. [16]
- (e) Produce a pictorial rendered drawing of the complete digger which shows all of the features that you have designed in (a) – (d). Do not include the child in this drawing. [16]

Permission to reproduce items where third-party owned material protected by copyright is included has been sought and cleared where possible. Every reasonable effort has been made by the publisher (UCLES) to trace copyright holders, but if any items requiring clearance have unwittingly been included, the publisher will be pleased to make amends at the earliest possible opportunity.

University of Cambridge International Examinations is part of the Cambridge Assessment Group. Cambridge Assessment is the brand name of University of Cambridge Local Examinations Syndicate (UCLES) which is itself a department of the University of Cambridge.