



UNIVERSITY OF CAMBRIDGE INTERNATIONAL EXAMINATIONS
General Certificate of Education
Advanced Subsidiary Level and Advanced Level

DESIGN AND TECHNOLOGY

9705/03

Paper 3

October/November 2007

3 hours

Additional Materials: Answer booklet/Paper
A range of design drawing equipment
A3 Drawing paper (5 sheets)



READ THESE INSTRUCTIONS FIRST

Write your Centre number, candidate number and name on all the work you hand in.
Write in dark blue or black pen.
You may use a soft pencil for any diagrams, graphs or rough working.
Do not use staples, paper clips, highlighters, glue or correction fluid.

Section A

Answer any **two** questions from **one** of the Parts **A**, **B** or **C**.

Section B

Answer **one** question.

All dimensions are in millimetres.

The instruction 'discuss' denotes that you should:

- examine critically the issues raised by the question;
- explain and interpret these issues as appropriate;
- introduce evidence wherever possible to support conclusions of arguments.

At the end of the examination, fasten all your work securely together.

The number of marks is given in brackets [] at the end of each question or part question.

This document consists of **11** printed pages and **1** blank page.



Section A

Answer **two** questions from **one** of the Parts A, B or C.

Part A – Product Design

1

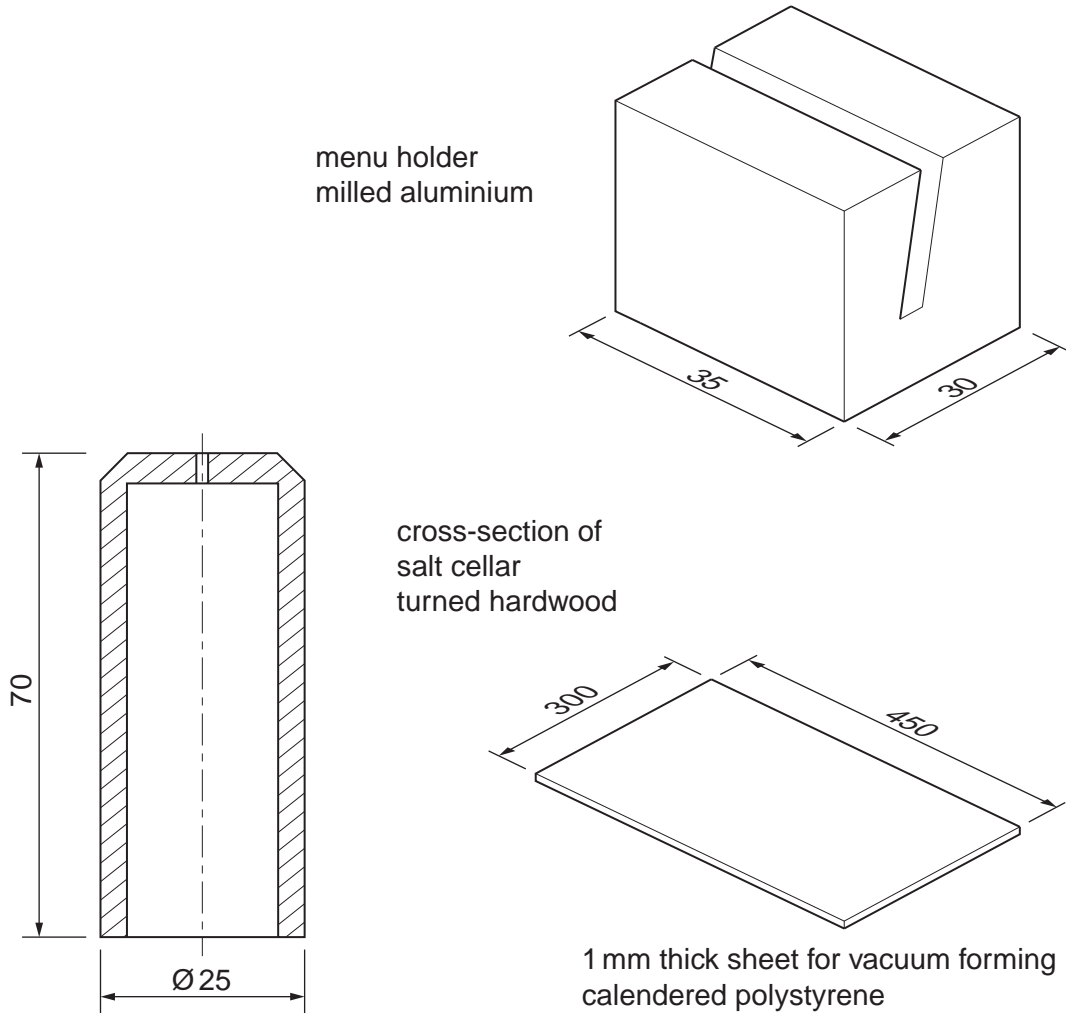

Fig. 1

Choose **two** of the items shown in Fig. 1 and for each:

(a) use notes and sketches to describe the manufacturing process that relates to the chosen item; [7 x 2]

(b) explain why the process is particularly suitable for the production of the item. [3 x 2]

3

- 2 Fig. 2 shows the design of a prototype support for an electric glue gun.

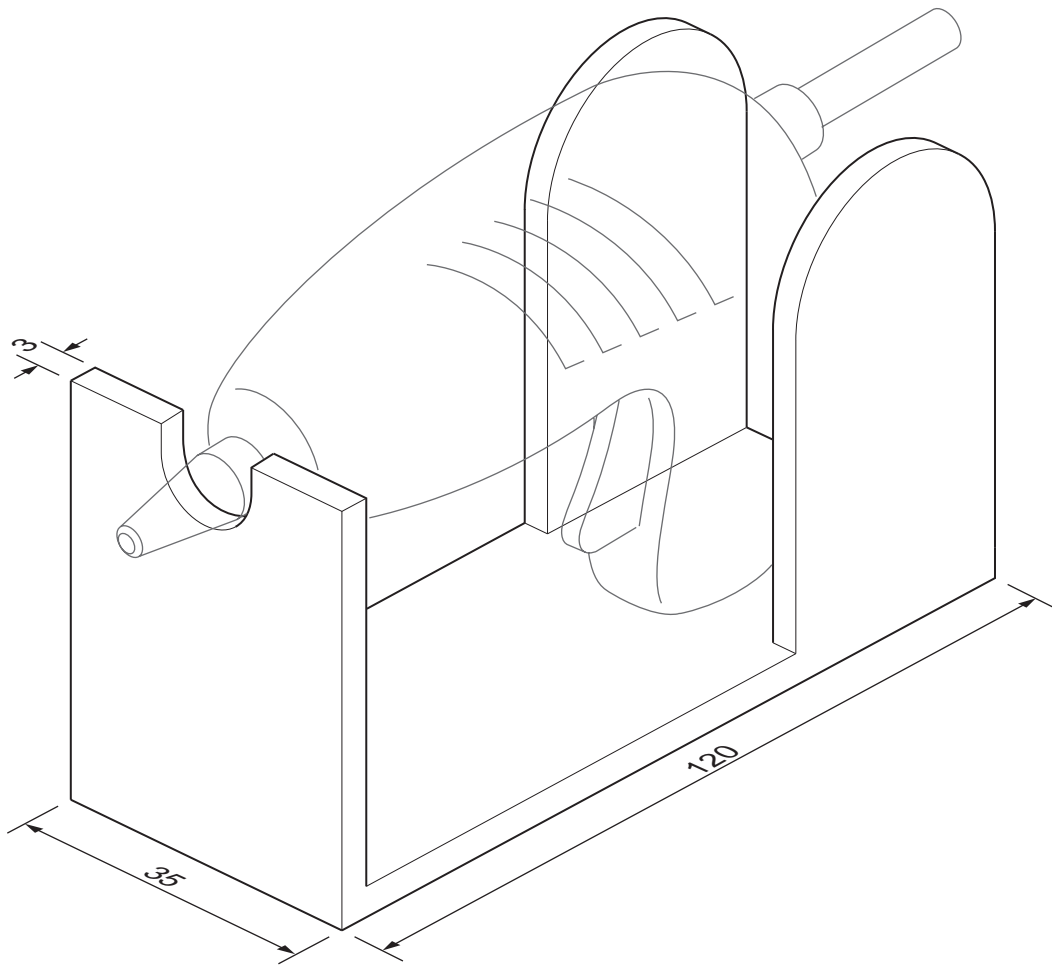

Fig. 2

- (a) State a suitable material for the support and give **two** reasons for your choice. [3]
- (b) Describe, using notes and sketches, how you would make the prototype support. [8]
- (c) Explain what changes may be necessary to the design, in the manufacturing method used and in the material selected if 5000 supports were required.

Use notes and sketches to support your answer. [9]

- 3 It is considered by many that 'product image' is the most important factor in the success of a product.

Discuss how the following will influence 'product image':

- (a) aesthetics; [10]
- (b) marketing strategies. [10]

Part B – Practical Technology

- 4 (a) Industry relies heavily on the use of alloys in the manufacture of products.
- (i) Name **two** alloys. [2]
 - (ii) State the specific materials used in each alloy. [4]
 - (iii) Identify a product for each of the alloys given in part (i) and explain why the alloys are particularly suitable for that application. [6]
- (b) (i) Use notes and sketches to describe a simple test to measure the tensile strength of a material. [5]
- (ii) Explain how you would record the results of a tensile test. [3]
- 5 (a) (i) Explain what is meant by the term 'ductile'. [2]
- (ii) State a material that is ductile. [1]
- (iii) Use notes and sketches to describe how 1 mm diameter metal wire is produced. [7]
- (b) Use notes and sketches to compare and contrast the processes of electric and gas welding. [10]

6 (a) Fig. 3 shows an arrangement of resistors in a circuit.

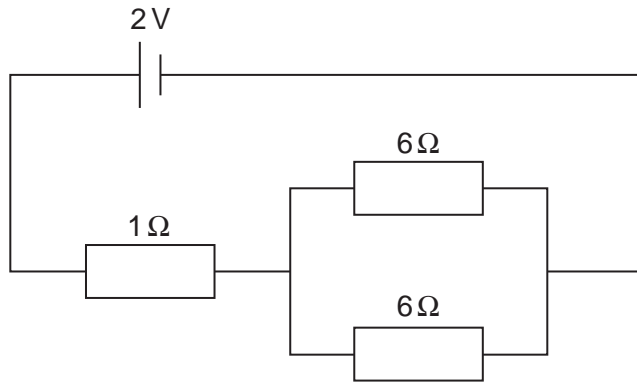

Fig. 3

- (i) Calculate the total resistance of the two 6 Ω resistors. [2]
- (ii) Calculate the current flowing in the 1 Ω resistor. [2]
- (iii) Calculate the current flowing in one of the 6 Ω resistors. [2]

(b) Calculate the output voltage at **V1** in the arrangement of resistors shown in Fig. 4. [3]

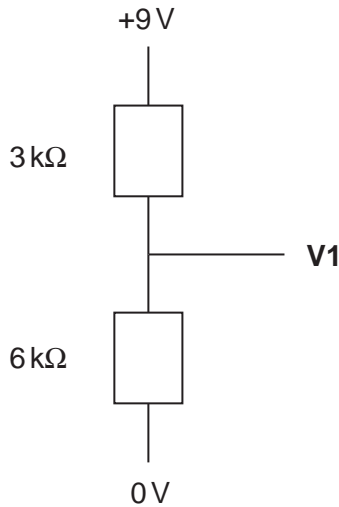

Fig. 4

(c) You are to design the circuit for a device that will draw the curtains of a nursery room when the temperature falls below a given level.

- (i) Draw a circuit that will:
 - activate a motor to draw the curtains in the room;
 - be able to pre-set closing temperatures between 14 °C and 20 °C;
 - have an indicator to show that the device is activated.

Clearly indicate the components required. [6]

- (ii) Describe what changes you would make to the circuit if the curtains were to be drawn and opened at pre-set times during the day. [5]

Part C – Graphic Products

7 Fig. 5 shows four examples of product packaging.

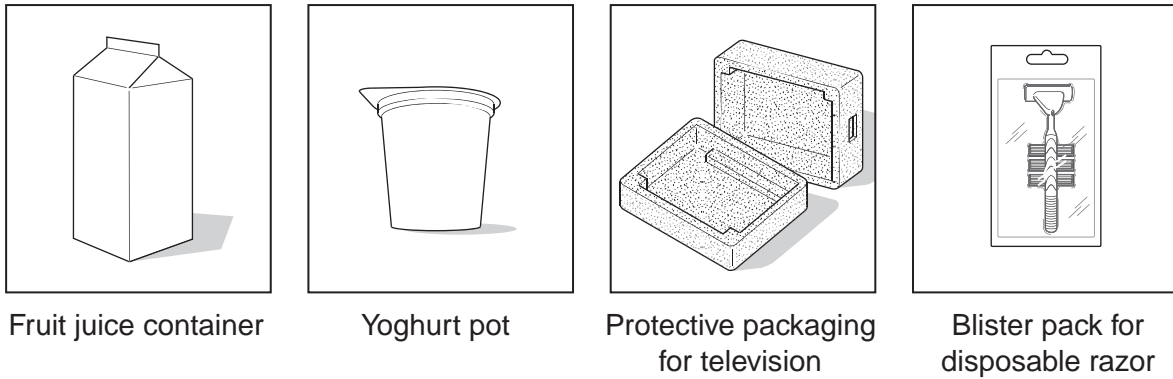

Fig. 5

- (a) (i) State a specific material suitable for the packaging for each of the examples given in Fig. 5. Give a different material for **each** example. [4]
- (ii) Select **two** of your answers given in part (i) and describe the properties that make them suitable for use as packaging material. [6]
- (b) Discuss the impact of Computer Aided Design and Computer Aided Manufacture (CAD/CAM) on the design of packaging. [10]

8 Fig. 6 shows an assembly drawing of a G-cramp.

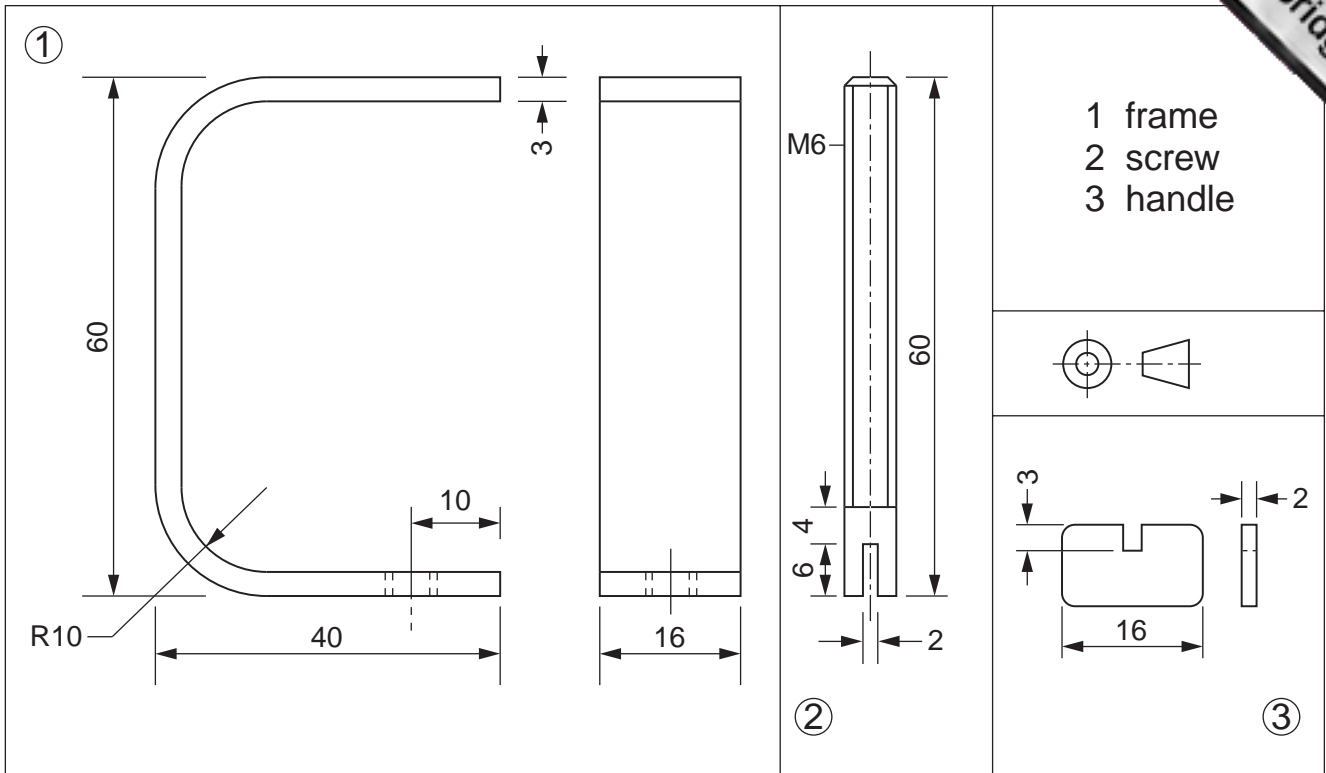

Fig. 6

(a) Produce an isometric drawing, twice full size, of the assembled G-cramp.

There is to be a gap of 25 mm from the top of the screw to the inside top of the frame. [12]

(b) Draw a freehand pictorial exploded drawing, approximately twice full size, of the G-cramp. [8]

9 Your school is taking part in a 'Healthy Heart' project to promote healthy eating. You are part of the design team working with the school kitchen/canteen to promote a range of new food products and make students more aware of healthy eating issues.

(a) A fold-up card container is required to serve individual salad portions such as lettuce, sliced carrot, cucumber and celery.

Design a prototype development (net) of a container which:

- is easy to assemble;
- is made from one sheet of A4 card;
- will include simple graphics to promote the product and campaign. [8]

(b) Describe, using sketches and notes, how you would make the prototype container. [4]

(c) Explain what changes may be necessary in the manufacture of 10 000 containers.

Use notes and sketches to support your answer. [8]

Section B

Answer **one** question on the A3 paper provided.

You should approach the design question of your choice in the following manner:

Analysis

Produce an analysis of the given situation/problem, which may be in written or graphical form. [5]

Specification

From the analysis produce a detailed written specification of the design requirements. Include at least five specification points other than those given in the question. [5]

Exploration

Use bold sketches and brief notes to show your exploration of ideas for a design solution, with reasons for selection. [25]

Development

Show using bold sketches and notes, the development, reasoning and composition of ideas into a single design proposal. Give details of materials, constructional and other relevant technical details. [25]

Proposed solution

Produce drawings of an appropriate kind to show the complete solution. [15]

Evaluation

Give a written evaluation of the final design solution. [5]

[Total: 80]

10 A room in a community centre is to be used by a play group for 3-5 year old children. The room consists of a maximum of eight children.

Design a unit which will enable children to hang up their outdoor clothing.

The unit must:

- be free standing, not attached to the walls;
- fold up or disassemble for easy storage when not in use.

To assist you in your answer, dimensions of items of clothing are given in Fig. 7.



Fig. 7

11 Many car drivers are unsure when driving conditions require them to put on main lights.

Design a device that will indicate to a driver that main lights must be switched on.

The device must:

- have a visual and/or audio signal to inform the driver;
- be securely positioned in the car.

To assist you in your answer, the dimensions of common batteries are given in Fig. 8.

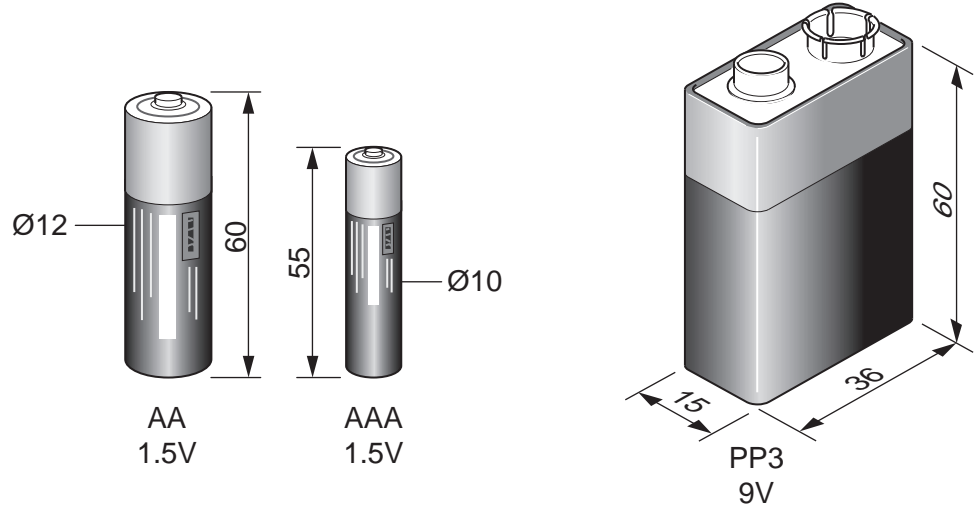

Fig. 8

12 A school is to have yearly elections to elect members for a school council. A number of voting booths which can be positioned around the school are required.

You are to design a voting booth, made mostly from thick card or suitable sheet material, which enable students to fill in their nominations in privacy.

The voting booth must:

- be easily assembled and disassembled for ease of storage;
- provide a surface for the voter to fill in the nomination form.

To assist you in your answer, anthropometric data is given in Fig. 9.

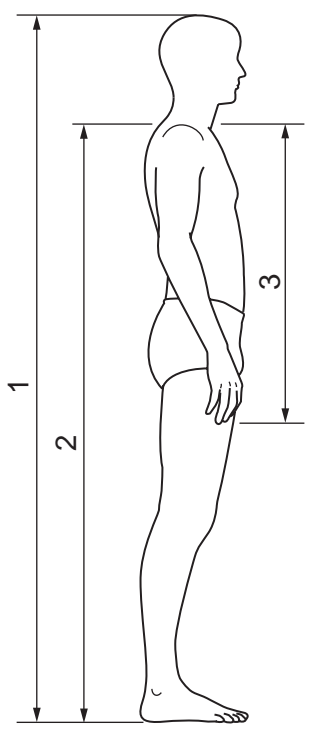

1	Height 11-18 year olds
	males 1700
	females 1650
2	Shoulder height 11-18 year olds
	males 1400
	females 1360
3	Arm length 11-18 year olds
	males 720
	females 700

Fig. 9

