



UNIVERSITY OF CAMBRIDGE INTERNATIONAL EXAMINATIONS  
General Certificate of Education  
Advanced Subsidiary Level and Advanced Level

**DESIGN AND TECHNOLOGY**

**9705/12**

Paper 1

**October/November 2009**

**3 hours**

Additional Materials: Answer Booklet/A4 Paper  
A3 Drawing paper (3 sheets)  
Extra sheets of A3 drawing paper for candidates  
who have used both sides of their 3 sheets  
A range of design drawing equipment



**READ THESE INSTRUCTIONS FIRST**

If you have been given an Answer Booklet, follow the instructions on the front cover of the Booklet.  
Write your answers and working on the separate Answer Booklet/Paper provided.  
Write your name, Centre number and candidate number on all the work you hand in.  
Write in dark blue or black pen.  
You may use a soft pencil, or coloured pencils/pens as appropriate, for any diagrams, graphs or rough working.  
Do not use staples, paper clips, highlighters, glue or correction fluid.  
**DO NOT WRITE ON ANY BARCODES.**

**Section A**

Answer **one** question on the Answer Booklet/A4 Paper provided.

**Section B**

Answer **one** question on the Answer Booklet/A4 Paper provided.

**Section C**

Answer **one** question on plain A3 paper.  
Use **both** sides of the paper.  
You may request additional sheets of A3 paper, but only if you have used both sides of each of the 3 sheets provided.

You are advised to spend **30 minutes** on each of Sections A and B and **2 hours** on Section C.

At the end of the examination, fasten all your work securely together.  
The number of marks is given in brackets [ ] at the end of each question or part question.  
All dimensions are in millimetres.

This document consists of **11** printed pages and **1** blank page.



Section A

Answer **one** question from this section on the Answer Booklet/A4 paper provided.

1 Fig. 1 shows a money box which is to be made in a school workshop.

The money box will be made from plywood.

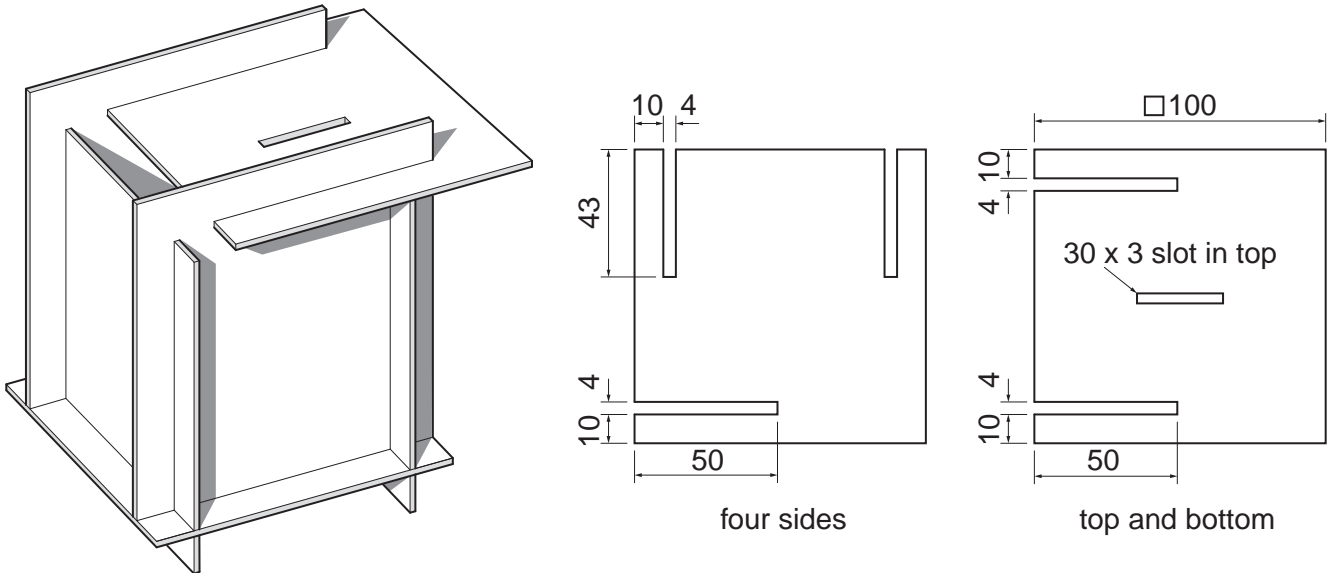

Fig. 1

- (a) Use notes and a sketch to explain what plywood looks like and what it is made from. [2]
- (b) Use notes and sketches to describe:
  - (i) how a template could be made and used to mark out the four sides; [6]
  - (ii) how one of the sides could be cut out, the slots made, and the edges of the plywood smoothed; [6]
  - (iii) how a varnish finish could be applied to the money box. [6]

You must give details about the tools, equipment and processes involved, and the safety precautions that must be taken at each stage.

2 Fig. 2 shows a door knocker which is to be made in a school workshop.

The door knocker will be used on an external door.

The door knocker will be made from two castings, hinged together at point A.

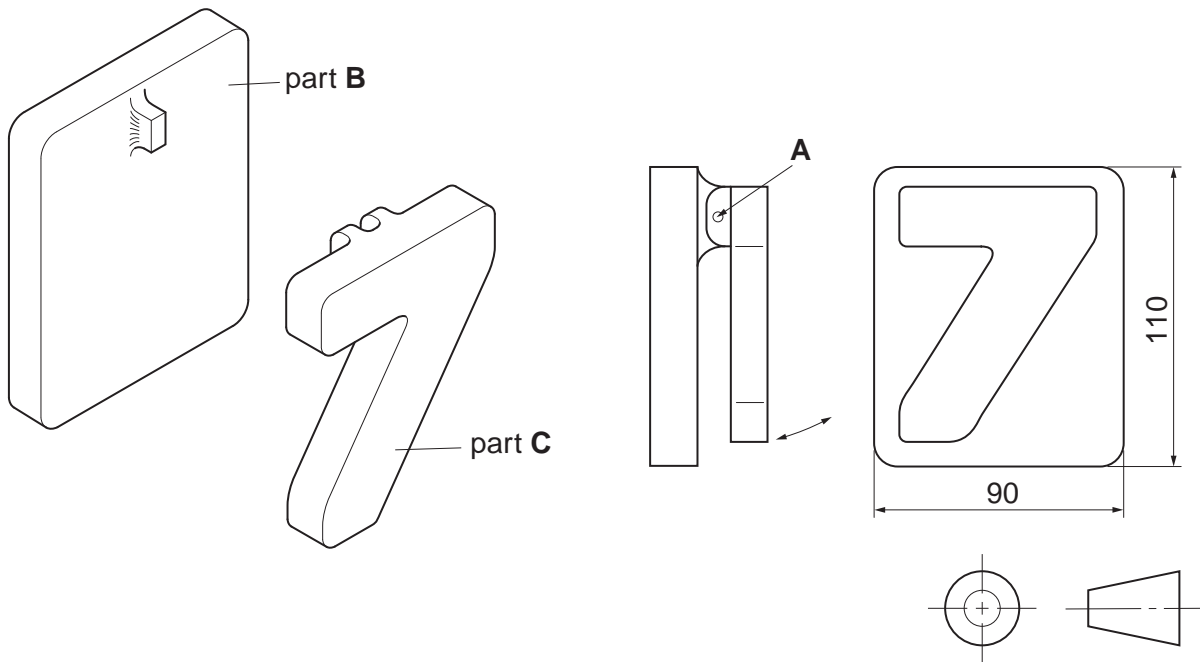

Fig. 2

(a) Name a suitable metal for making the two castings and give **one** reason for your choice. [2]

(b) Use notes and sketches to describe:

(i) how the pattern required to cast part B could be made; [6]

(ii) how part B could be cast; [6]

(iii) how parts B and C could be joined at point A so that they hinge. [6]

You must give details about the tools, equipment and processes involved, and the safety precautions that must be taken at each stage.

3 Fig. 3 shows a tray to be made in a school workshop.

The tray will be made from corrugated cardboard, and will be used to hold copies of the prospectus.

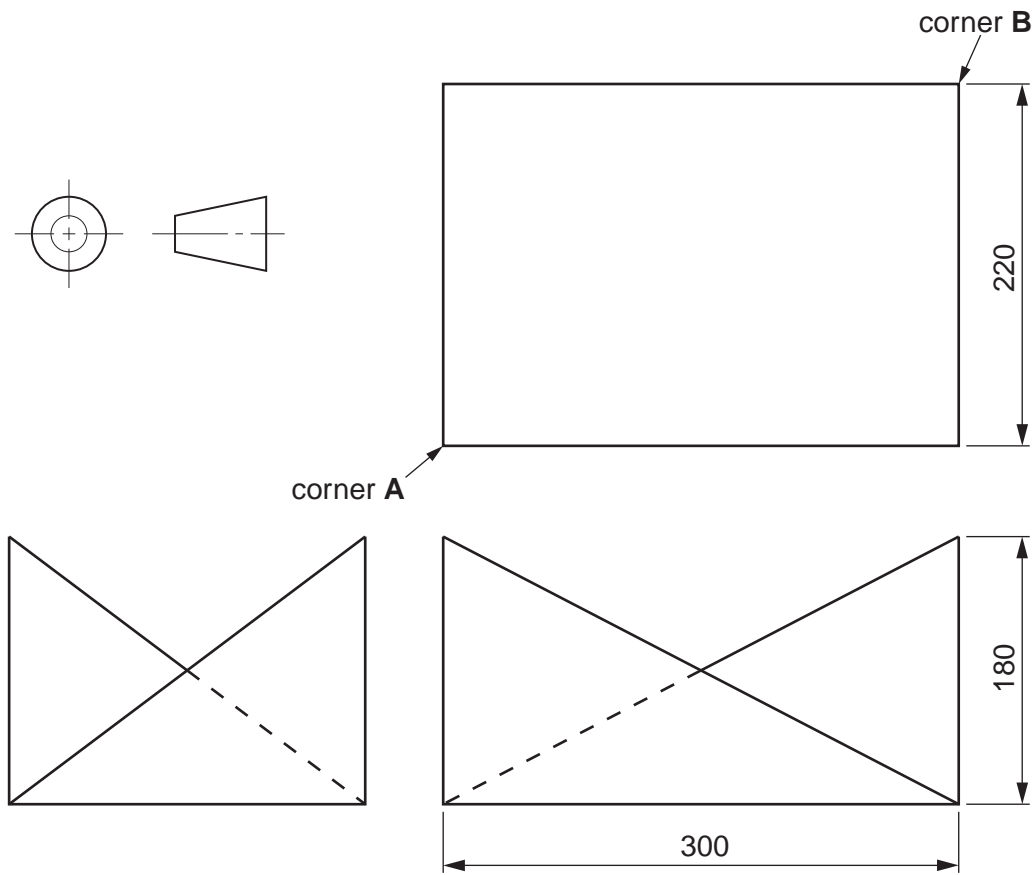

Fig. 3

- (a) Use notes and a sketch to explain what corrugated cardboard looks like. [2]
- (b) Use notes and sketches to describe how corners **A** and **B** could be securely joined together without the use of glue or other additional materials. [6]
- (c) Sketch, to an appropriate scale, the development (net) required to make the tray. [6]

5

Fig. 4 shows the school's prospectus.

The logo on the front cover has been embossed.

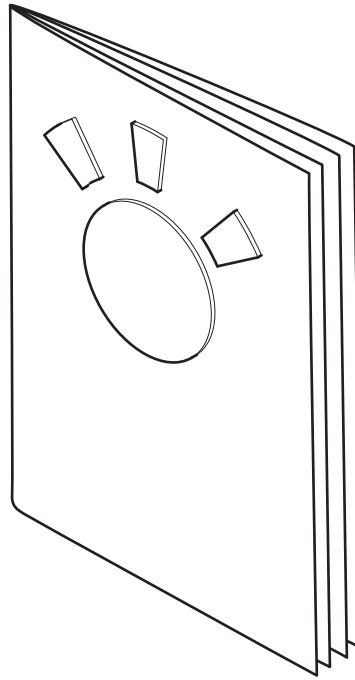

Fig. 4

(d) Use notes and sketches to describe the embossing process.

[6]

You must give details about the tools, equipment and processes involved, and the safety precautions that must be taken at each stage.

6

## Section B

Answer **one** question from this section on the Answer Booklet/A4 paper provided.

- 4 Fig. 5 shows a piece of furniture and a knock-down (temporary) fitting.

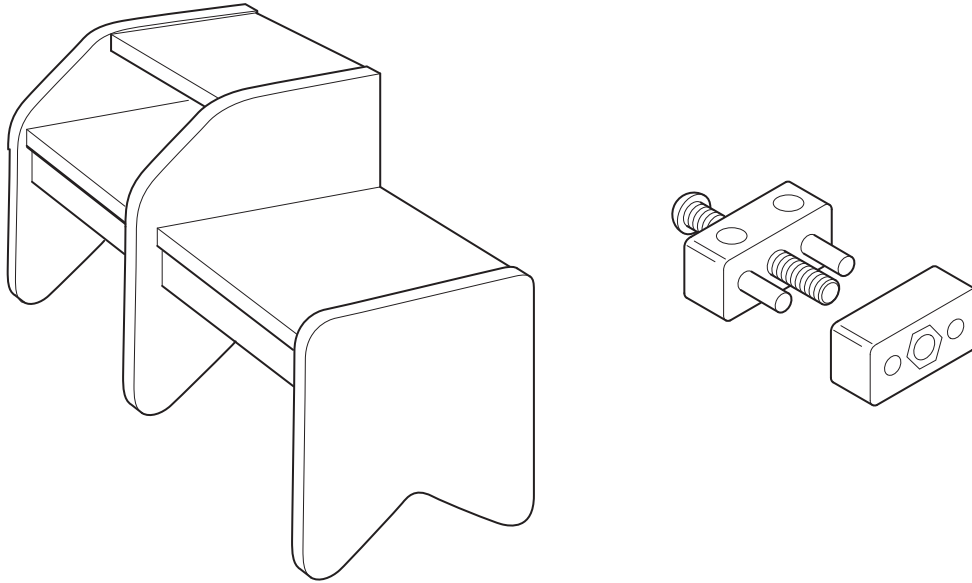

Fig. 5

- (a) Use a sketch and notes to explain how the knock-down fitting could be used to join two parts of the furniture together. [2]
- (b) Describe **two** problems that a person might have when assembling a piece of knock-down furniture. [4]
- (c) Explain how the manufacturer of the furniture could solve the two problems that you have identified in (b). [6]
- (d) Discuss why knock-down fittings have, to a large extent, replaced more traditional joining methods such as mortice and tenon joints, and dovetail joints.

Your answer should:

- (i) analyse the given situation and identify three relevant issues raised by the question; [3]
- (ii) explain why you consider these issues to be relevant; [3]
- (iii) contain specific examples/evidence as support for your conclusions. [2]

5 Fig. 6 shows an office chair, and a proposed design for a desk to be used with the chair.

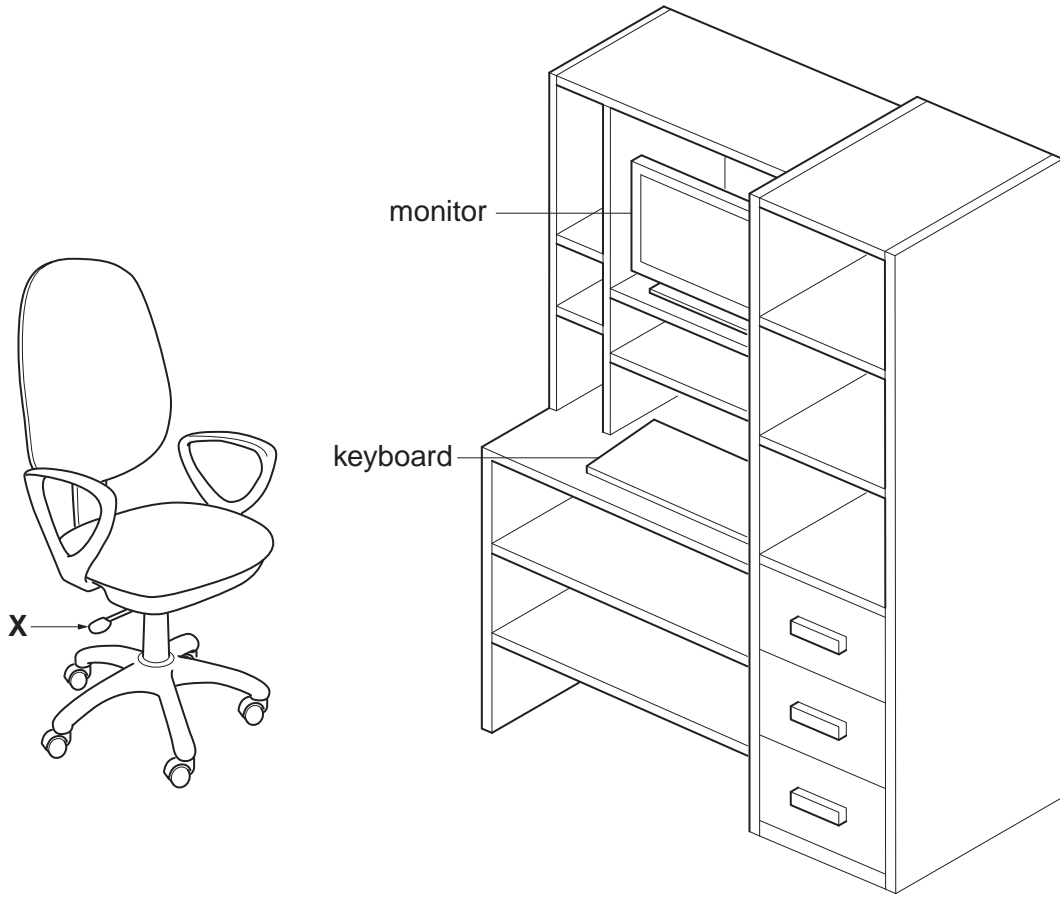

Fig. 6

- (a) Explain the use of the design feature labelled X. [2]
- (b) Describe **two** problems with the proposed design for the desk. [4]
- (c) Using notes and sketches, explain how the design would need to be changed to overcome the two problems you have identified in (b). [6]
- (d) Discuss how the design of the chair shown in Fig. 6 has been influenced by its intended use.

Your answer should:

- (i) analyse the given situation and identify three relevant issues raised by the question; [3]
- (ii) explain why you consider these issues to be relevant; [3]
- (iii) contain specific examples/evidence to support your conclusions. [2]

6 Fig. 7 shows a counter top stand to display a mobile phone. The stand is made from card coated with a UV lacquer.

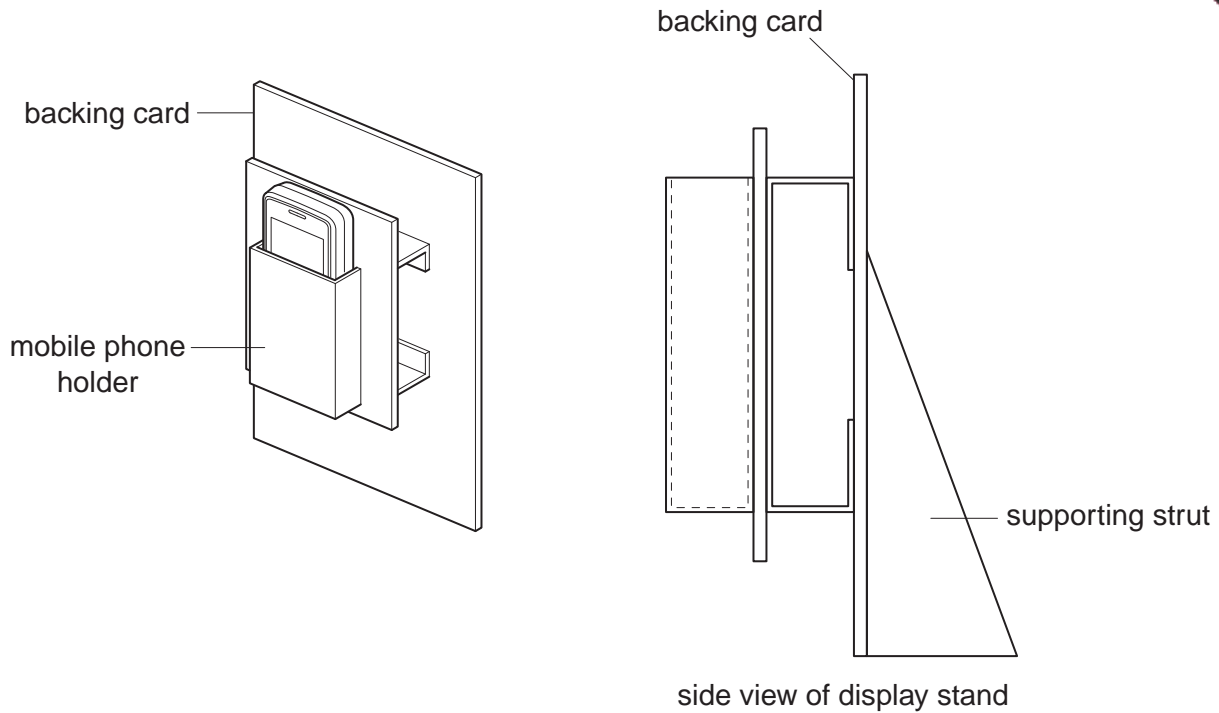

Fig. 7

- (a) Explain why a UV lacquer has been applied to the display stand. [2]
- (b) Describe **two** problems with the design. [4]
- (c) Using notes and sketches, explain how the design would need to be changed to overcome the two problems you have identified in (b). [6]
- (d) Discuss why the manufacturing cost of counter-top display stands should be kept as low as possible.

Your answer should:

- (i) analyse the given situation and identify three relevant issues raised by the question; [3]
- (ii) explain why you consider these issues to be relevant; [3]
- (iii) contain specific examples/evidence as support for your conclusions. [2]



## Section C

Answer **one** question from this section on the plain A3 paper provided.

You are provided with three sheets of plain A3 paper. You should use **both** sides of the paper. **Each** of the five parts **(a) – (e)** of the question that you choose to answer should take up one side of paper.

When you are asked to **develop** a design you must show, using sketches and notes, the development and evaluation of a **range** of ideas into a single design proposal. The design proposal should be annotated to give details about materials, joining methods and important sizes.

7 Fig. 8 shows an incomplete design for a pair of bunk beds.

The beds can be stacked one on top of the other as shown or be taken apart and used as two separate beds.

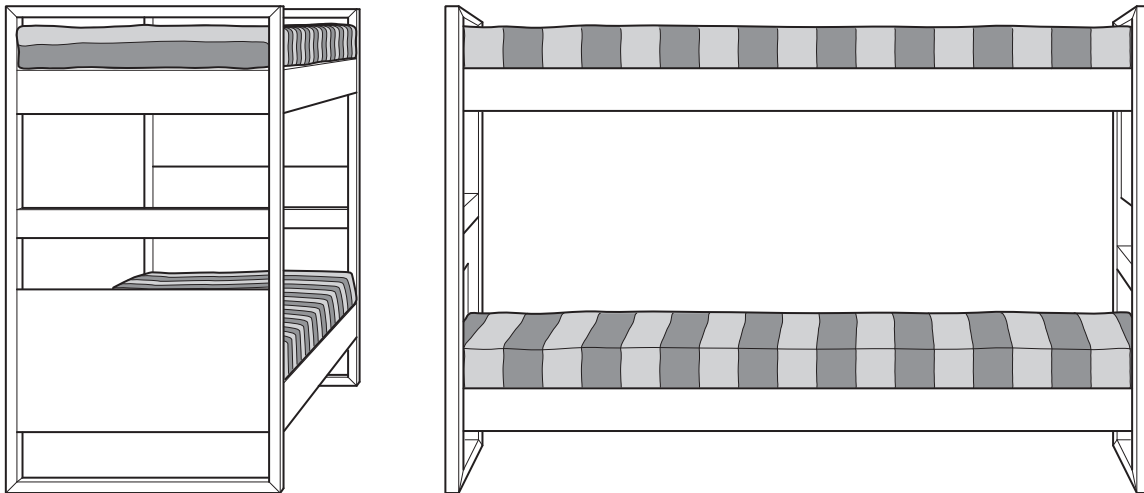

Fig. 8

- (a) Using notes and sketches, **develop** a design which would prevent a young child falling off the top bunk bed. [16]
- (b) Using notes and sketches, **develop** a design for a ladder which would allow a young child to climb up to the top bunk bed. [16]
- (c) Using notes and sketches, **develop** a design for a storage system to go under the bottom bunk bed. [16]
- (d) Using notes and sketches, **develop** a design which secures the two bunk beds together, but can easily be removed when the beds are used separately. [16]
- (e) Produce a pictorial rendered drawing of the complete bunk beds which shows all of the features that you have designed in **(a) – (d)**. [16]

- 8 Fig. 9 shows an incomplete design for a bicycle trailer.

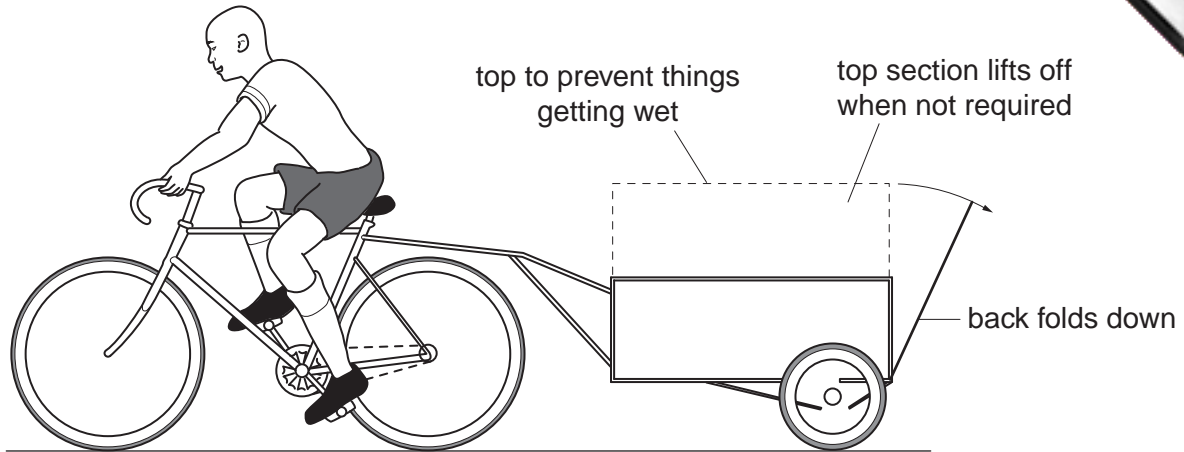

Fig. 9

- (a) Using notes and sketches, **develop** a design which allows the trailer to be easily attached to and removed from the bicycle. [16]
- (b) Using notes and sketches, **develop** a design which allows the wheels to be easily attached to and removed from the axle of the trailer. [16]
- (c) Using notes and sketches, **develop** a design for the top section of the trailer. This is to include a secure method of joining the two parts together, while still allowing the top section to be removed when necessary. [16]
- (d) Using notes and sketches, **develop** a design for the fold-down back of the trailer. When closed the back must be securely held in place. [16]
- (e) Produce a pictorial rendered drawing of the complete trailer which shows all of the features that you have designed in (a) – (d). [16]

- 9 Fig. 10 shows an incomplete design for the cardboard packaging that will be used to transport a new Tiger Mountain Bike made by Wild Cat Cycles.

The pedals are removed and the handle bars are turned sideways so that the packaging takes up less space.

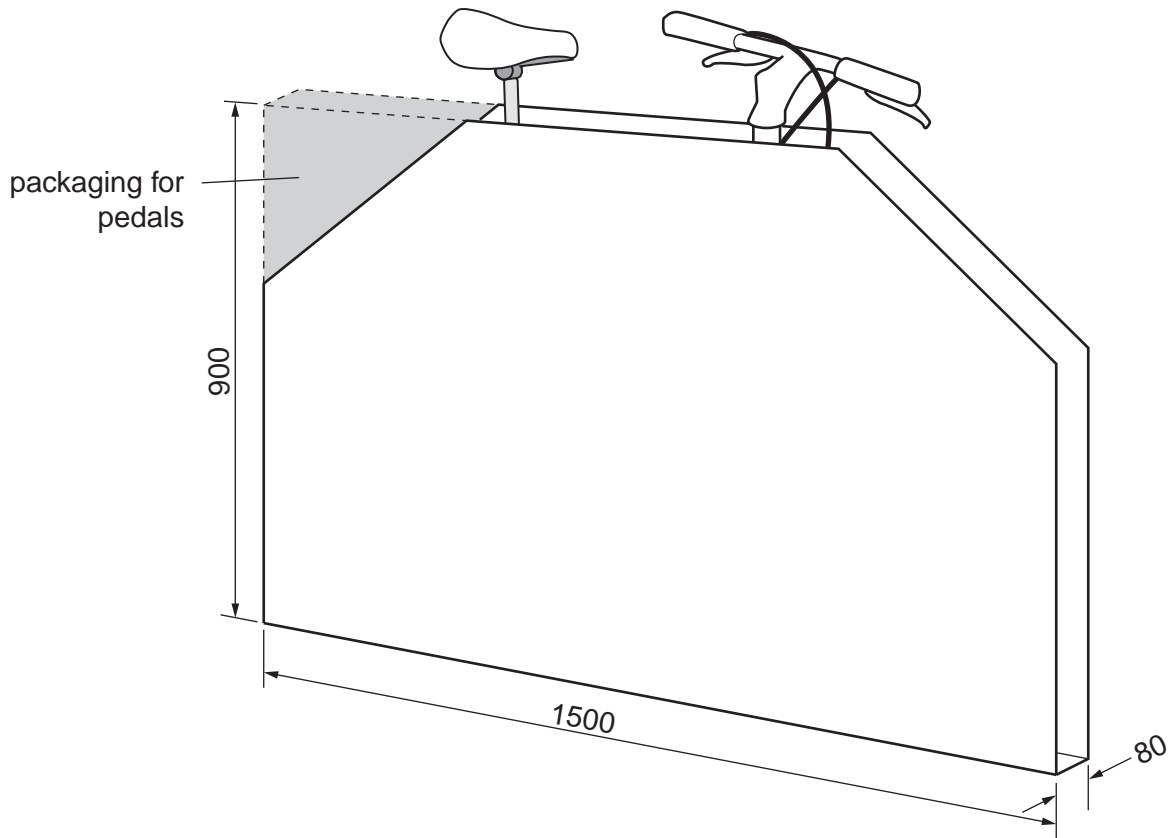

Fig. 10

- (a) Using notes and sketches, **develop** a design which fastens the packaging around the bike but allows it to be removed and replaced without causing any damage to the packaging. [16]
- (b) Using notes and sketches, **develop** a design which allows the packaged bike to be easily carried by one person. [16]
- (c) Using notes and sketches, **develop** a design for packaging the pedals. This must be capable of being attached to the main packaging, as shown in Fig. 10, without the use of glue or any other additional materials. [16]
- (d) Using notes and sketches, **develop** a design for the lettering to go on the packaging. This consists of the company name, **Wild Cat Cycles**, and the name of the bike, **Tiger Mountain Bike**. [16]
- (e) Produce a pictorial rendered drawing of the complete packaging which shows all of the features that you have designed in (a) – (d). [16]

---

Permission to reproduce items where third-party owned material protected by copyright is included has been sought and cleared where possible. Every reasonable effort has been made by the publisher (UCLES) to trace copyright holders, but if any items requiring clearance have unwittingly been included, the publisher will be pleased to make amends at the earliest possible opportunity.

University of Cambridge International Examinations is part of the Cambridge Assessment Group. Cambridge Assessment is the brand name of University of Cambridge Local Examinations Syndicate (UCLES), which is itself a department of the University of Cambridge.