



UNIVERSITY OF CAMBRIDGE INTERNATIONAL EXAMINATIONS
General Certificate of Education
Advanced Subsidiary Level and Advanced Level

DESIGN AND TECHNOLOGY

9705/12

Paper 1

October/November 2011

3 hours

Additional Materials: Answer Booklet/A4 Paper
A3 Drawing Paper (3 sheets)
Extra sheets of A3 drawing paper for candidates who have used up both sides of their 3 sheets
A range of design drawing equipment



READ THESE INSTRUCTIONS FIRST

If you have been given an Answer Booklet, follow the instructions on the front cover of the Booklet.

Write your name, Centre number and candidate number on all the work you hand in.

Write in dark blue or black pen.

You may use a soft pencil, or coloured pencils/pens as appropriate, for any diagrams, graphs or rough working.

Do not use staples, paper clips, highlighters, glue or correction fluid.

Section A

Answer **one** question on the Answer Booklet/A4 Paper provided.

Section B

Answer **one** question on the Answer Booklet/A4 Paper provided.

Section C

Answer **one** question on plain A3 paper.

Use **both** sides of the paper.

You may request additional sheets of A3 paper, but only if you have used up both sides of each of the 3 sheets provided.

You are advised to spend **30 minutes** on each of Sections A and B and **2 hours** on Section C.

At the end of the examination, fasten all your work securely together.

The number of marks is given in brackets [] at the end of each question or part question.

All dimensions are in millimetres.

This document consists of **11** printed pages and **1** blank page.



Section A

Answer **one** question from this section on the Answer Booklet/A4 paper provided.

- 1 Fig. 1 gives details about a mechanical toy which is to be made in a school workshop.

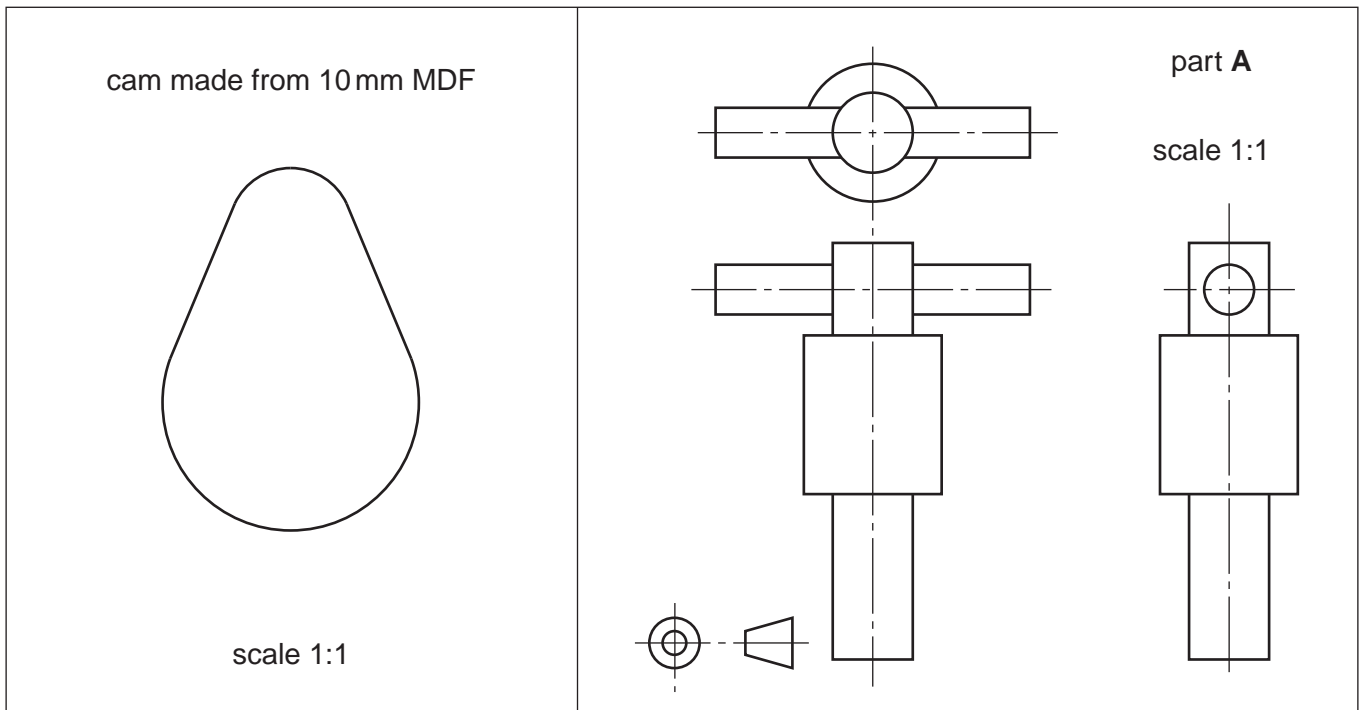
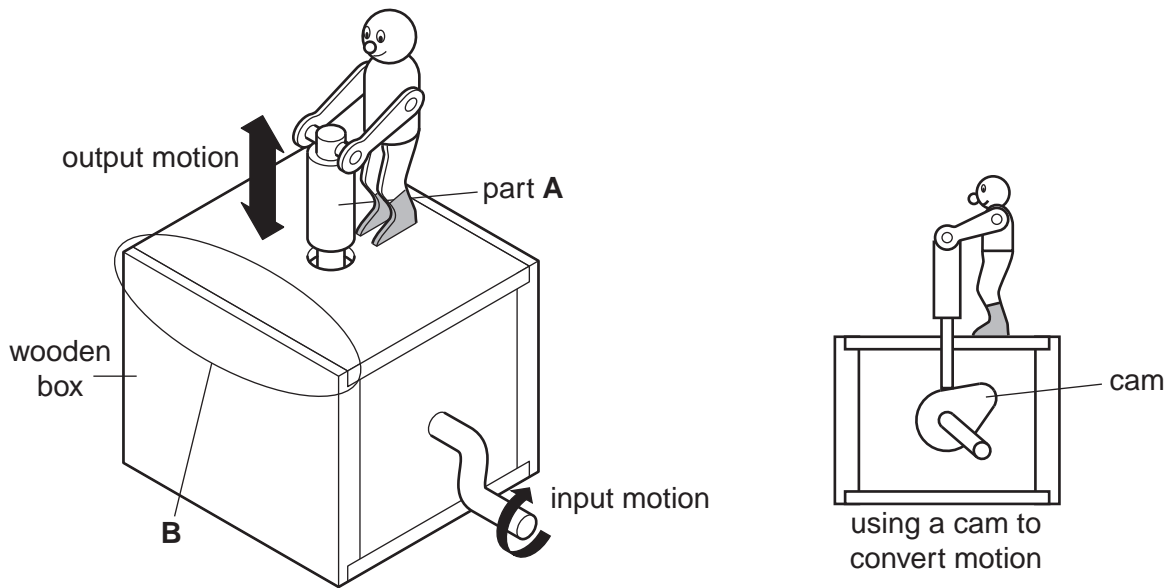

Fig. 1

- (a) (i) Name the input motion. [1]
(ii) Name the output motion. [1]

3

(b) Use notes and sketches to describe:

- (i) how the cam could be cut out and the edges of the MDF smoothed;
- (ii) how part **A** could be made;
- (iii) how the joint shown at **B** could be made.

[6]

You must give details about the tools, equipment and processes involved and the safety precautions that have to be undertaken at each stage.

2 Fig. 2 shows a pencil rack which is to be made in a school workshop.

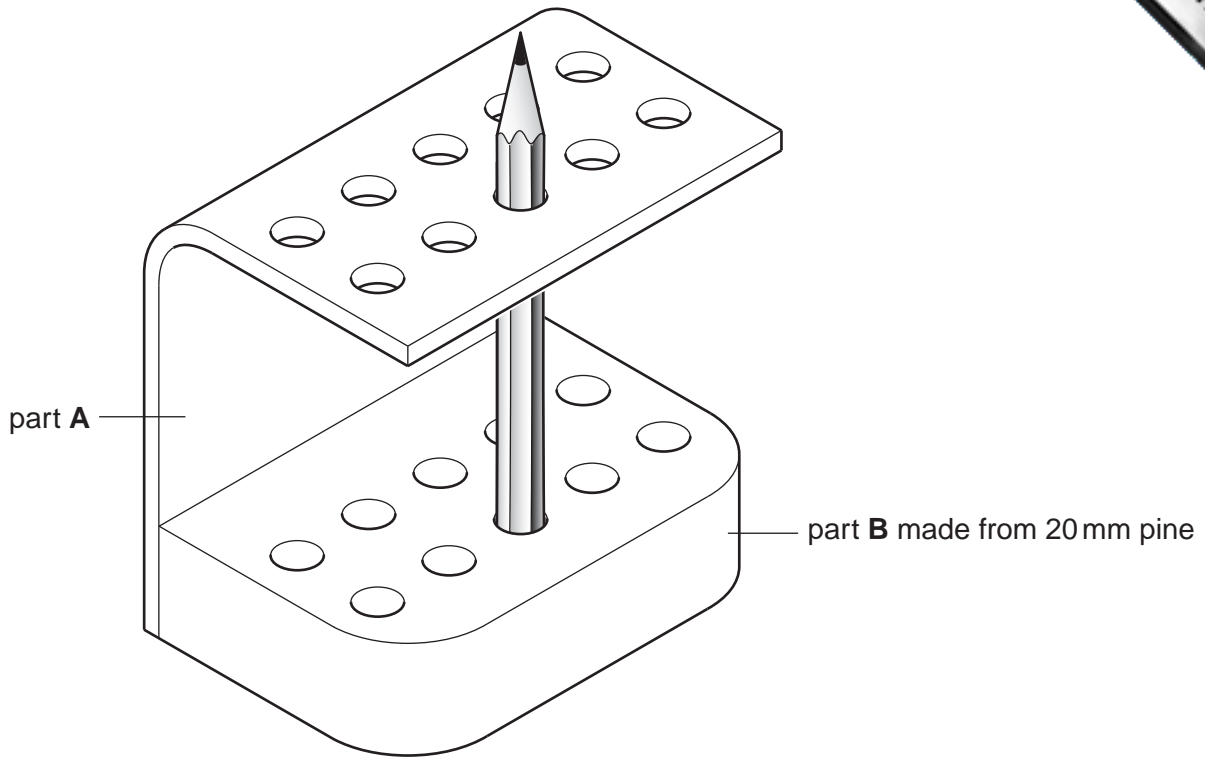

Fig. 2

- (a) Name a suitable sheet material for making part **A** and give **one** reason for your choice. [2]
- (b) Use notes and sketches to describe:
 - (i) how part **A** could be bent; [6]
 - (ii) how the rounded corners on part **B** could be cut out and the edges of the wood smoothed; [6]
 - (iii) how parts **A** and **B** could be joined together using countersunk screws. [6]

You must give details about the tools, equipment and processes involved and the safety precautions that have to be undertaken at each stage.

3 Fig. 3 shows a children's playhouse which is to be made in a school workshop. The playhouse is to be made from four separate pieces of corrugated cardboard.

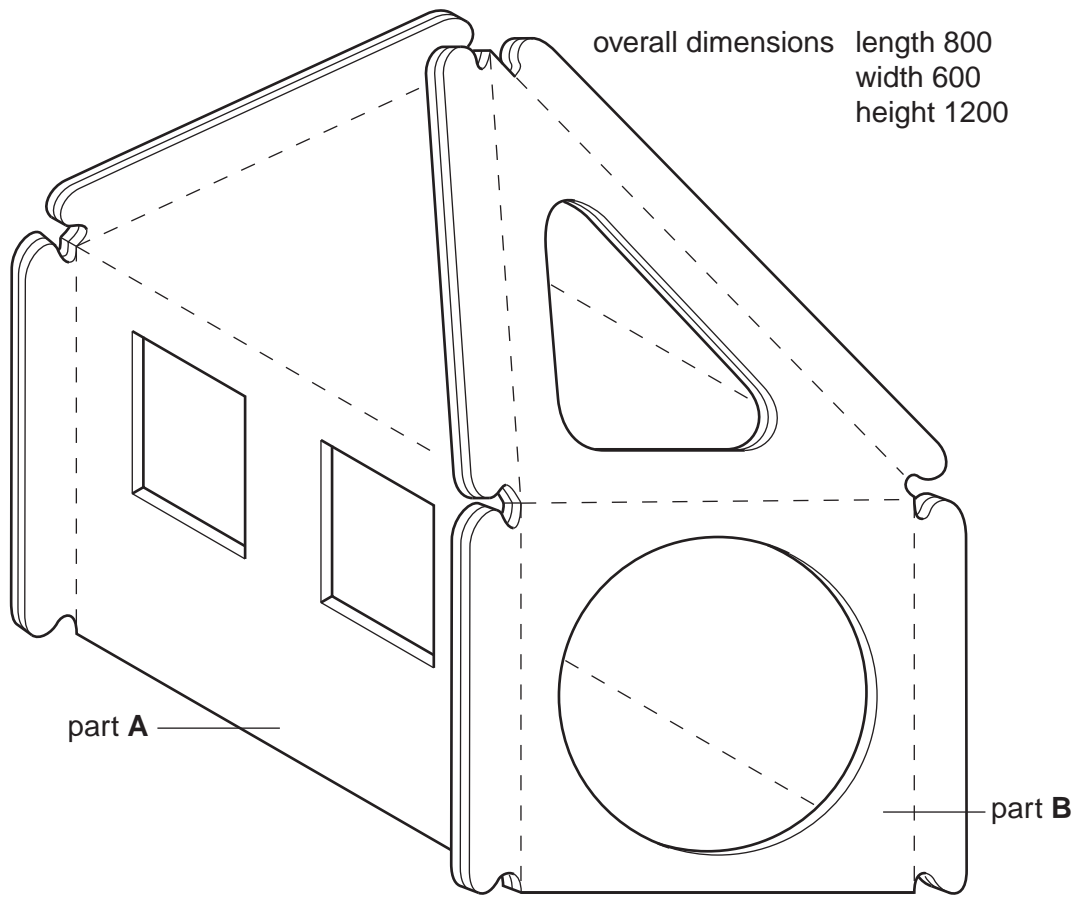

Fig. 3

- (a) Use notes and a sketch to explain what corrugated cardboard looks like. [2]
- (b) Sketch, to an appropriate scale, the development (net) required to make:
 - (i) part A; [3]
 - (ii) part B. [3]
- (c) Use notes and sketches to describe:
 - (i) how part A could be cut out and the folds made; [6]
 - (ii) the stages required to assemble the four separate parts using large elastic bands. [6]

You must give details about the tools, equipment and processes involved and the safety precautions that have to be taken at each stage.

Section B

Answer **one** question from this section on the Answer Booklet/A4 paper provided.

- 4 Fig. 4 shows an incomplete design for a page in a child's pop-up book and a symbol that will be printed on the back of the book.

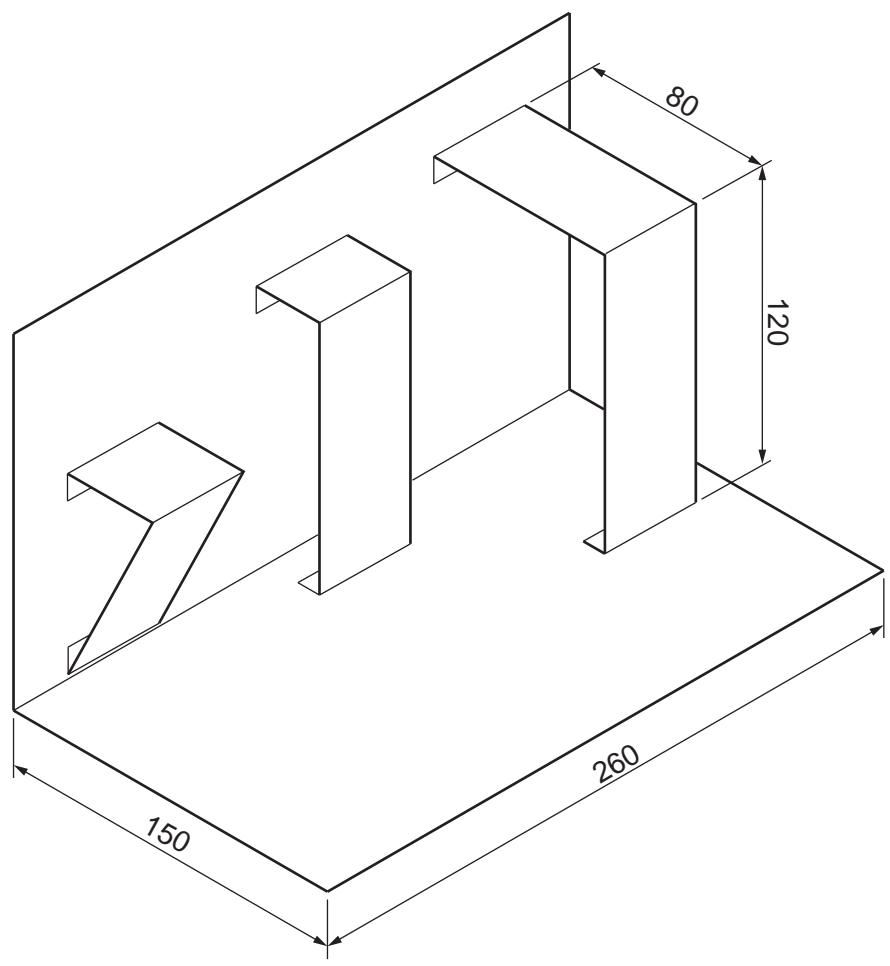

symbol that will be printed on back of book

Fig. 4

- (a) Explain what the symbol means. [2]
- (b) Describe **two** problems with the design of the page. [4]
- (c) Using notes and sketches, explain how the design would need to be changed to overcome the two problems you have identified in (b). [6]
- (d) Discuss how the designers and authors of books for children aged 2–6 years old use different types of surface finish to enhance the visual and tactile appeal of their books.

Your answer should:

- (i) analyse the given situation and identify three relevant issues raised by the question; [3]
- (ii) explain why you consider these issues to be relevant; [3]
- (iii) contain specific examples/evidence to support your conclusions. [2]

5 Each of the three products shown in Fig. 5 uses a different power source.

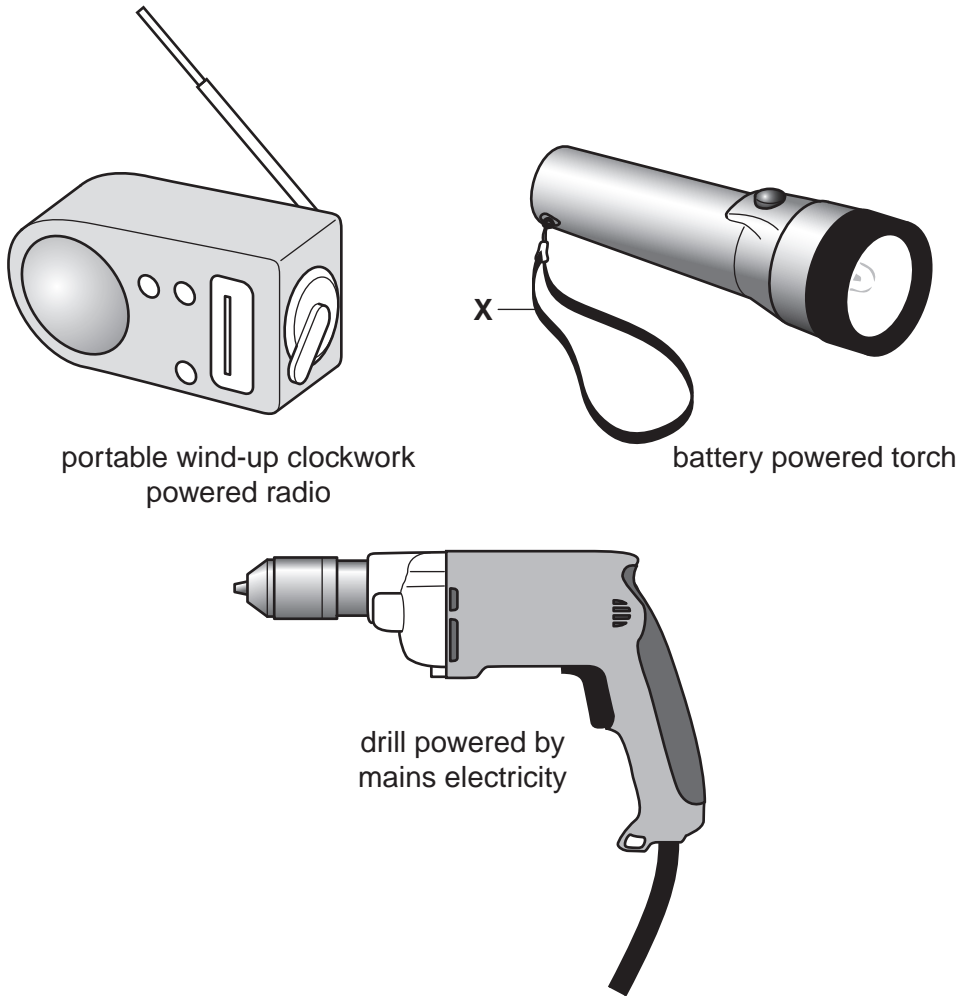

portable wind-up clockwork powered radio

battery powered torch

drill powered by mains electricity

Fig. 5

- (a) Explain the purpose of the design feature shown at X. [2]
- (b) Describe **two** problems with the design of the clockwork radio. [4]
- (c) Using notes and sketches, explain how the design would need to be changed to overcome the two problems you have identified in (b). [6]
- (d) Select **one** of the power sources used by the products shown in Fig. 5 and discuss the merits of using that power source compared to the other two.

You answer should:

- (i) analyse the given situation and identify three relevant issues raised by the question; [3]
- (ii) explain why you consider these issues to be relevant; [3]
- (iii) contain specific examples/evidence as support for your conclusions. [2]

6 Fig. 6 shows a range of designs for folding chairs and stools.

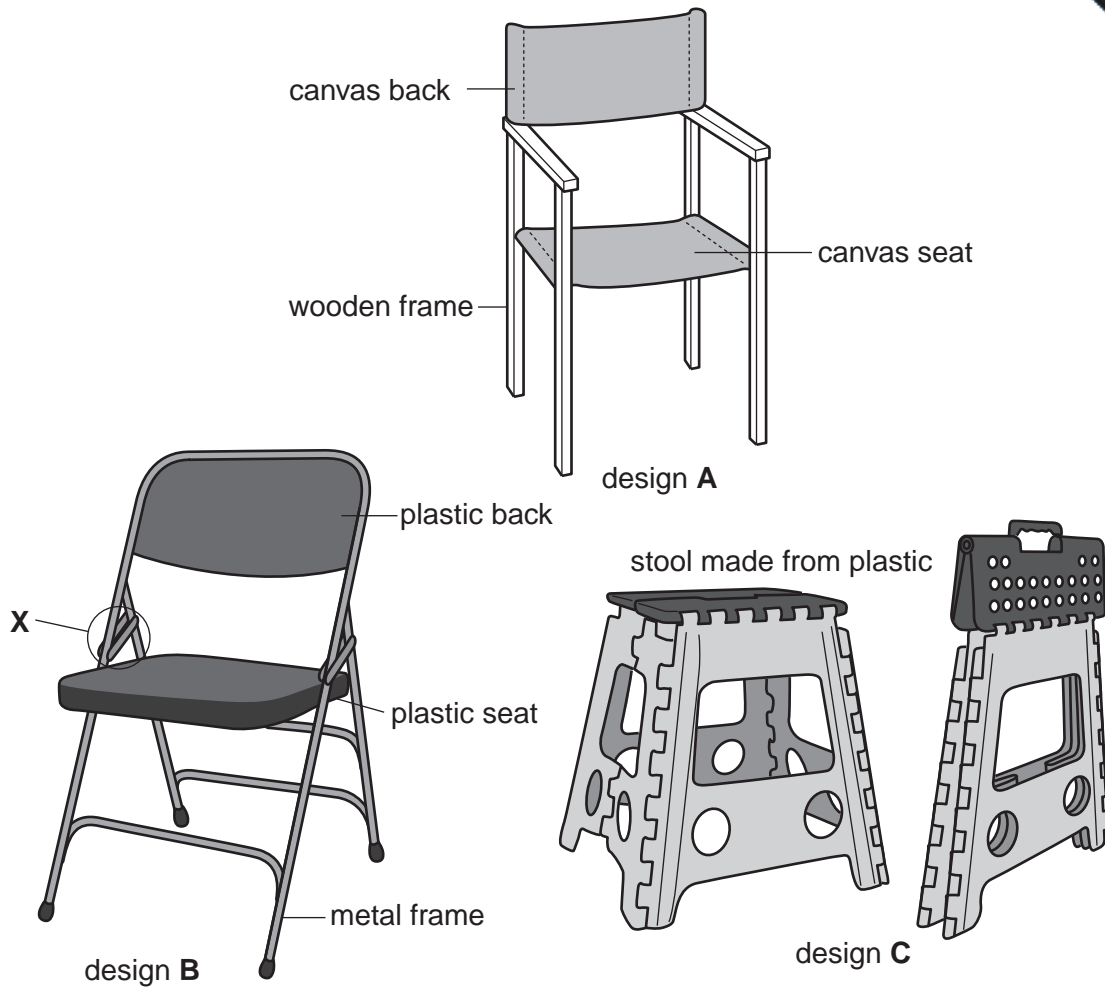

Fig. 6

- (a) Explain the function of the design feature shown at X. [2]
- (b) Describe **two** problems with design A. [4]
- (c) Using notes and sketches, explain how the design would need to be changed to overcome the two problems you have identified in (b). [6]
- (d) Discuss why design A might be considered more 'environmentally friendly' than the other designs shown in Fig. 6.

Your answer should:

- (i) analyse the given situation and identify three relevant issues raised by the question; [3]
- (ii) explain why you consider these issues to be relevant; [3]
- (iii) contain specific examples/evidence as support for your conclusions. [2]

Section C

Answer **one** question from this section on the plain A3 paper provided.

You are provided with three sheets of plain A3 paper. You should use **both** sides of the paper. **Each** of the five parts (a) – (e) of the question that you choose to answer should take up one side of the paper.

When you are asked to **develop** a design you must show, using notes and sketches, the development and evaluation of a range of ideas into a single design proposal. The design proposal should be annotated to give details about materials, joining methods and important sizes.

7 Fig. 7 shows an incomplete design for a seesaw to be used by children.

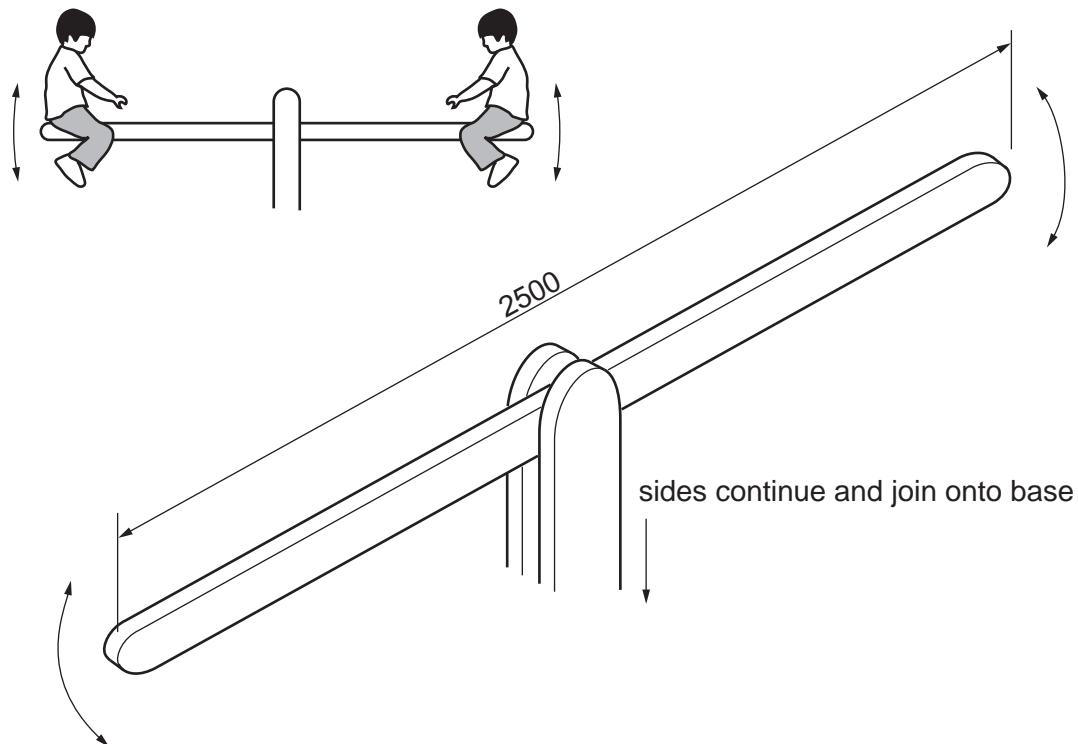

Fig. 7

- (a) Using notes and sketches, **develop** a design for the base of the seesaw. The base must keep the seesaw stable but not be permanently fixed to the ground. [16]
- (b) Using notes and sketches, **develop** a design for a seat which could be attached to each end of the seesaw. [16]
- (c) Using notes and sketches, **develop** a design for a handle that a child could hold on to when sitting in the seat. [16]
- (d) Using notes and sketches, **develop** a design which allows the seesaw to pivot. It must be possible to remove the pivot so that the two parts of the seesaw can be easily stored. [16]
- (e) Produce a pictorial rendered drawing of the complete seesaw which shows all of the features that you have designed in (a) – (d). [16]

- 8 Fig. 8 shows an incomplete design for a display stand. The stand will be used to hold brochures and leaflets for 'The Mountain Holiday Company'. The stand will be manufactured in flat form from 5 mm thick corrugated cardboard.

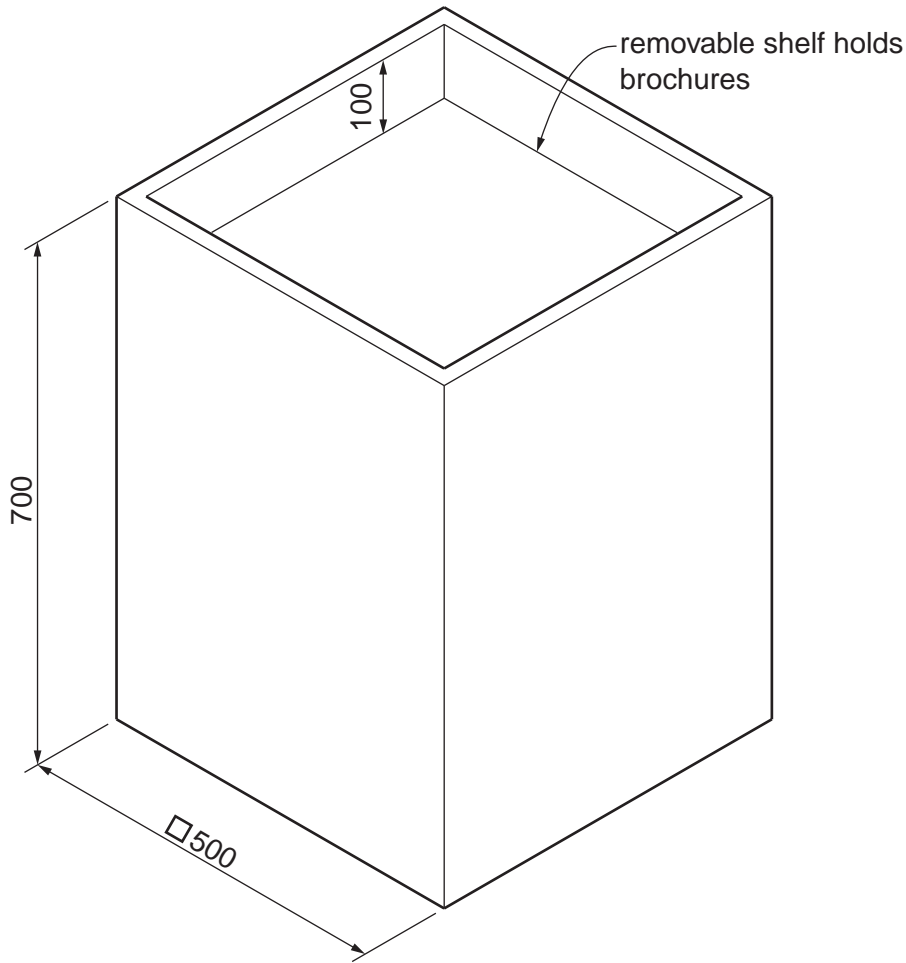

Fig. 8

- (a) Using notes and sketches, **develop** a design which supports the shelf 100 mm below the top edge but allows the shelf to be removed so that the stand can be folded flat. [16]
- (b) Using notes and sketches, **develop** a design for an information board that could be attached to, and easily removed from, the back of the stand. The shape of the board must reflect the name of the company. [16]
- (c) Using notes and sketches, **develop** a design for a leaflet holder. This must be capable of being attached to the display stand without the use of glue or any other additional materials. [16]
- (d) Using notes and sketches, **develop** a design for the lettering to go on the display stand. This should consist of the company name 'The Mountain Holiday Company' and should be in a style that reflects the name. [16]
- (e) Produce a pictorial rendered drawing of the complete display stand which shows all of the features that you have designed in (a) – (d). [16]

- 9 Fig. 9 shows an incomplete design for a bicycle repair stand.

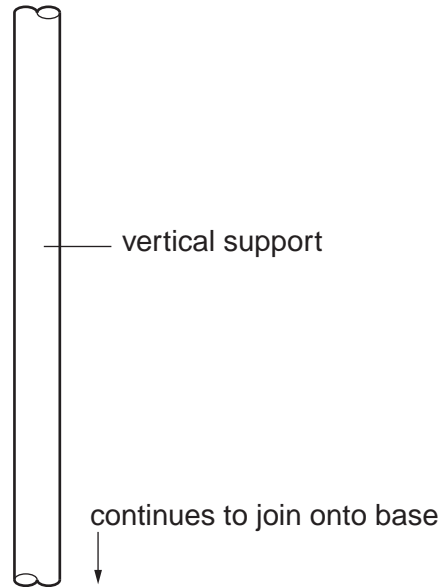

Fig. 9

- (a) Using notes and sketches, **develop** a design for the base of the stand. [16]
- (b) Using notes and sketches, **develop** a design which allows the vertical support to be adjusted and fixed at different heights. [16]
- (c) Using notes and sketches, **develop** a design which allows the bicycle to be attached to the vertical support. [16]
- (d) Using notes and sketches, **develop** a design for a storage tray to hold tools which could be attached to the stand. [16]
- (e) Produce a pictorial rendered drawing of the complete bicycle repair stand which shows all of the features that you have designed in (a) – (d). [16]

Permission to reproduce items where third-party owned material protected by copyright is included has been sought and cleared where possible. Every reasonable effort has been made by the publisher (UCLES) to trace copyright holders, but if any items requiring clearance have unwittingly been included, the publisher will be pleased to make amends at the earliest possible opportunity.

University of Cambridge International Examinations is part of the Cambridge Assessment Group. Cambridge Assessment is the brand name of University of