



UNIVERSITY OF CAMBRIDGE INTERNATIONAL EXAMINATIONS
General Certificate of Education
Advanced Subsidiary Level and Advanced Level

DESIGN AND TECHNOLOGY

9705/13

Paper 1

October/November 2013

3 hours

Additional Materials: Answer Booklet/A4 Paper
A3 Drawing Paper (2 sheets)
Extra sheets of A3 drawing paper for candidates who have used up both sides of their 2 sheets
A range of design drawing equipment

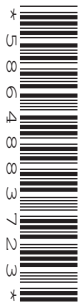

READ THESE INSTRUCTIONS FIRST

If you have been given an Answer Booklet, follow the instructions on the front cover of the Booklet.

Write your name, Centre number and candidate number on all the work you hand in.

Write in dark blue or black pen.

You may use a soft pencil, or coloured pencils/pens as appropriate, for any diagrams, graphs or rough working.

Do not use staples, paper clips, highlighters, glue or correction fluid.

DO NOT WRITE IN ANY BARCODES.

Section A

Answer **one** question on the Answer Booklet/A4 Paper provided.

Section B

Answer **one** question on the Answer Booklet/A4 Paper provided.

Section C

Answer **one** question on plain A3 paper.

Use **both** sides of the paper.

You may request additional sheets of A3 paper, but only if you have used up both sides of each of the 2 sheets provided.

You are advised to spend **30 minutes** on each of Sections A and B and **2 hours** on Section C.

At the end of the examination, fasten all your work securely together.

The number of marks is given in brackets [] at the end of each question or part question.

All dimensions are in millimetres.

This document consists of **12** printed pages and **4** blank pages.



Section A

Answer **one** question from this section on the Answer Booklet/A4 paper provided.

1 Fig. 1 shows an adjustable mirror, made from pine and acrylic, which is to be constructed in a school workshop.

(a) Give **two** reasons why part **A** will be made from acrylic rather than glass. [2]

(b) Use notes and sketches to describe:

(i) how the grooves in the wooden frame, that part **A** fits into, could be made; [6]

(ii) how a dowel joint, for fixing parts **B** and **C** together could be made; [6]

(iii) how part **B** could be made on a wood turning lathe. [6]

You must give details about the tools, equipment and processes involved and the safety precautions that have to be undertaken at each stage.

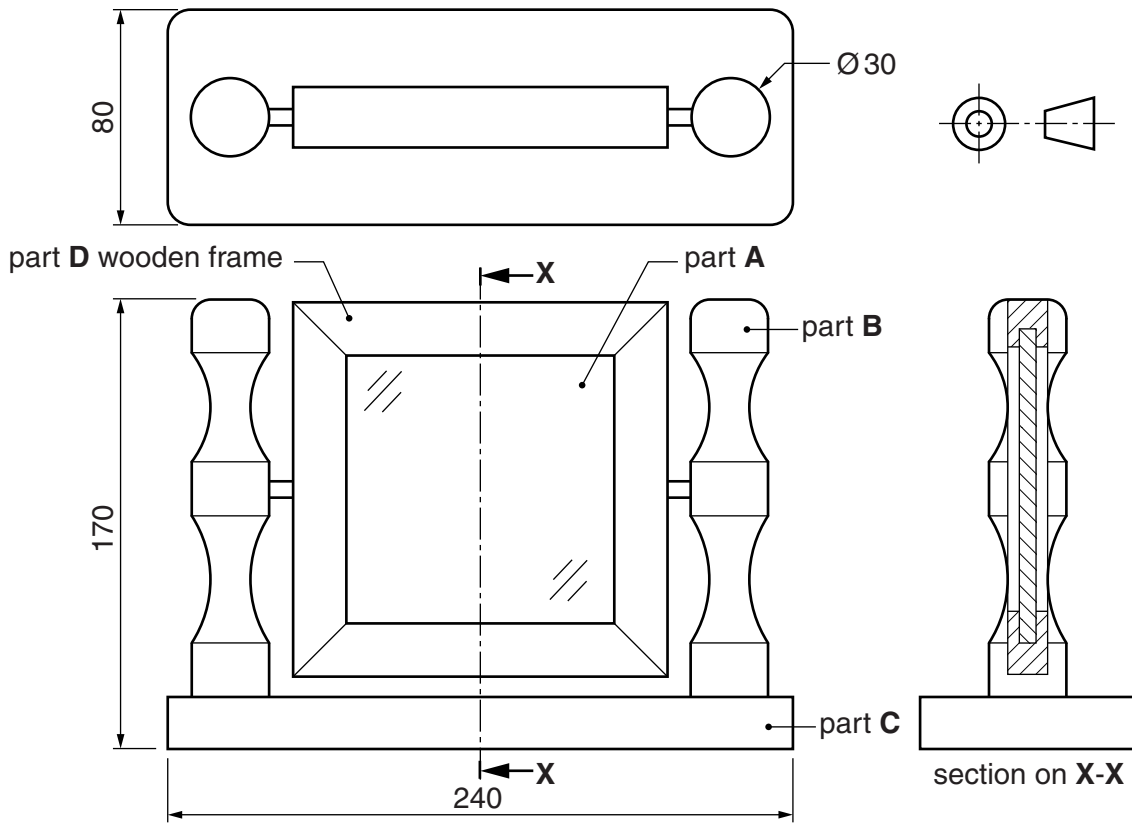

Fig. 1

2 Fig. 2 shows an outdoor fire which is to be made in a school workshop. The fire will be made from five separate pieces of mild steel sheet.

- (a) Name a suitable finish that could be used on the fire and give **one** reason for your choice.
- (b) Use notes and sketches to describe:
 - (i) how the hole could be made in part **B** and how the edges of the mild steel could be smoothed; [6]
 - (ii) how parts **A** and **B** could be welded together; [6]
 - (iii) how the holes in part **C** could be marked out with the aid of a template and then drilled. [6]

You must give details about the tools, equipment and processes involved and the safety precautions that have to be undertaken at each stage.

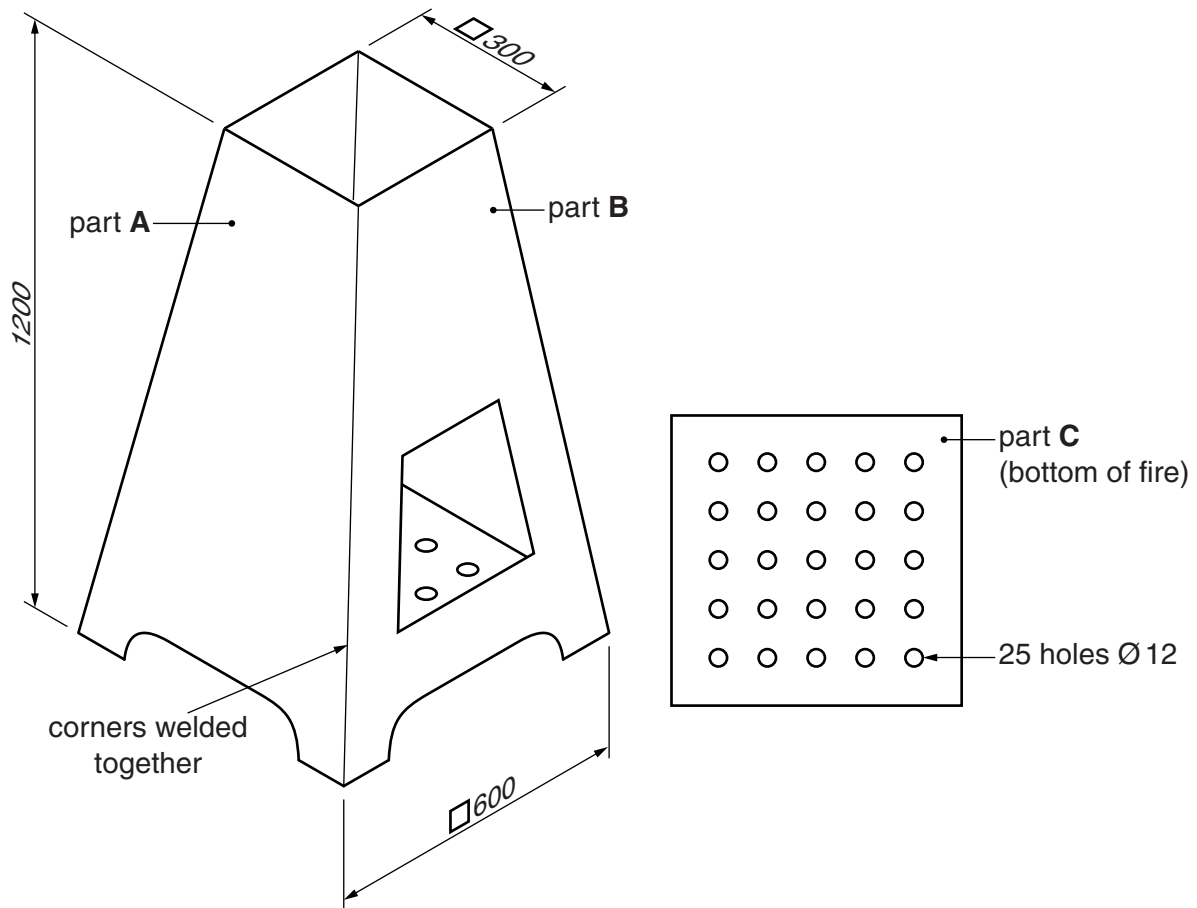

Fig. 2

3 Fig. 3 shows an idea for a ticket to a concert to be given by a band called 'The Tunes'. The design will be produced on a computer using tools from the toolbar shown in Fig. 3.

- (a) Use a sketch and notes to explain what perforated means.
- (b) Use notes and sketches to describe:
 - (i) how with the toolbar a text style, size and colour could be chosen and how the text could be added to the ticket; [6]
 - (ii) how with the toolbar a photograph could be imported from a digital camera and re-sized to fit the space on the ticket; [6]
 - (iii) how with the toolbar the logo could be drawn and coloured red. [6]

You must give details about the tools, equipment and processes involved.

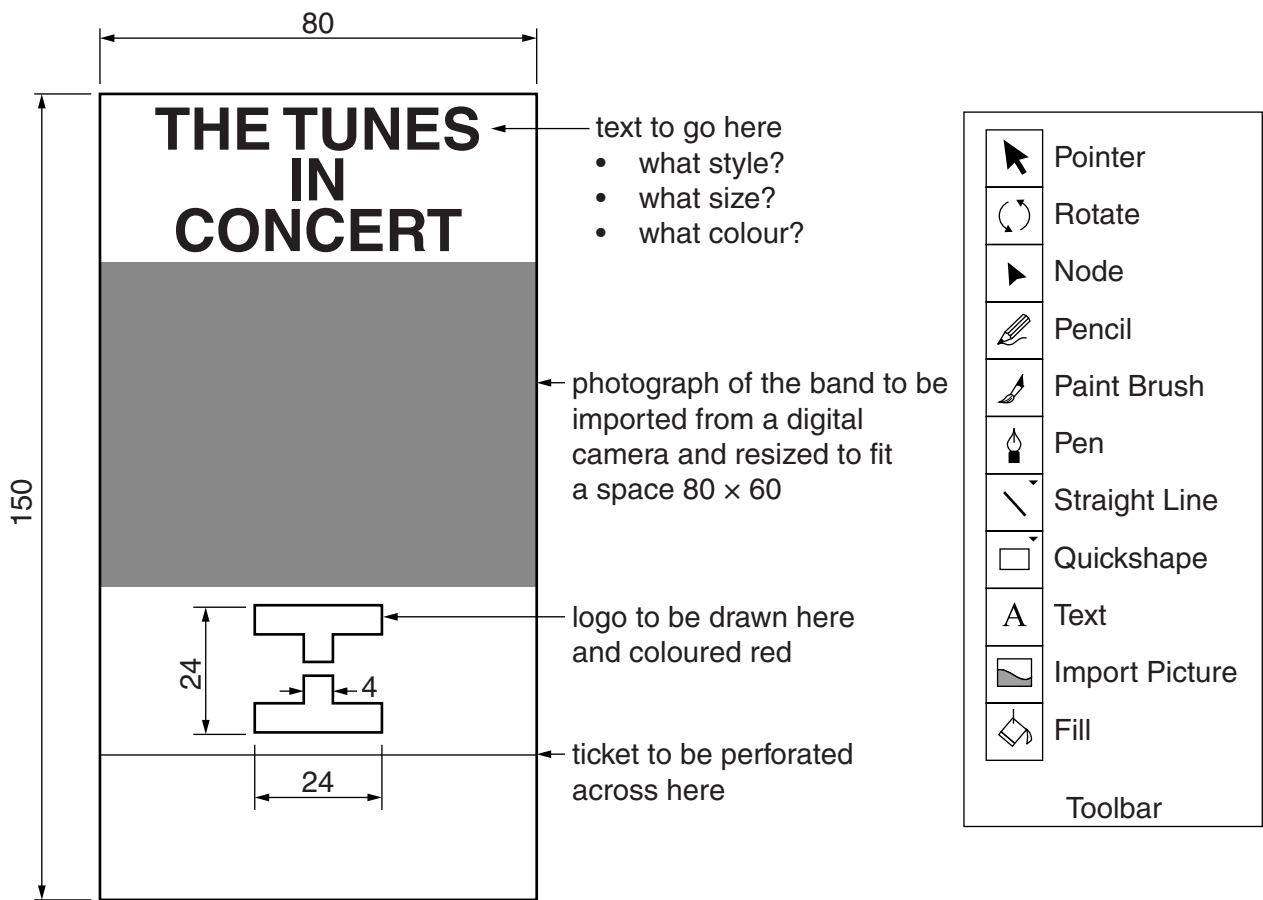

Fig. 3

5
BLANK PAGE

Section B

Answer **one** question from this section on the Answer Booklet/A4 paper provided.

- 4 Fig. 4 shows a design for a paper cup and the development (net) for making a card sleeve. The sleeve slides onto the cup and prevents people burning their fingers when they hold the cup filled with a hot drink.
- (a) The cup is biodegradable. Explain what this means. [2]
- (b) Identify and describe **two** problems with the shape of the card sleeve. [4]
- (c) Using notes and sketches, explain how the shape would need to be changed to overcome the two problems you have identified in (b). [6]
- (d) Discuss how and why manufacturers consider sustainability when designing new products.

Your answer should:

- (i) analyse the given situation and identify three relevant issues raised by the question; [3]
- (ii) explain why you consider these issues to be relevant; [3]
- (iii) contain specific examples/evidence to support your conclusions. [2]

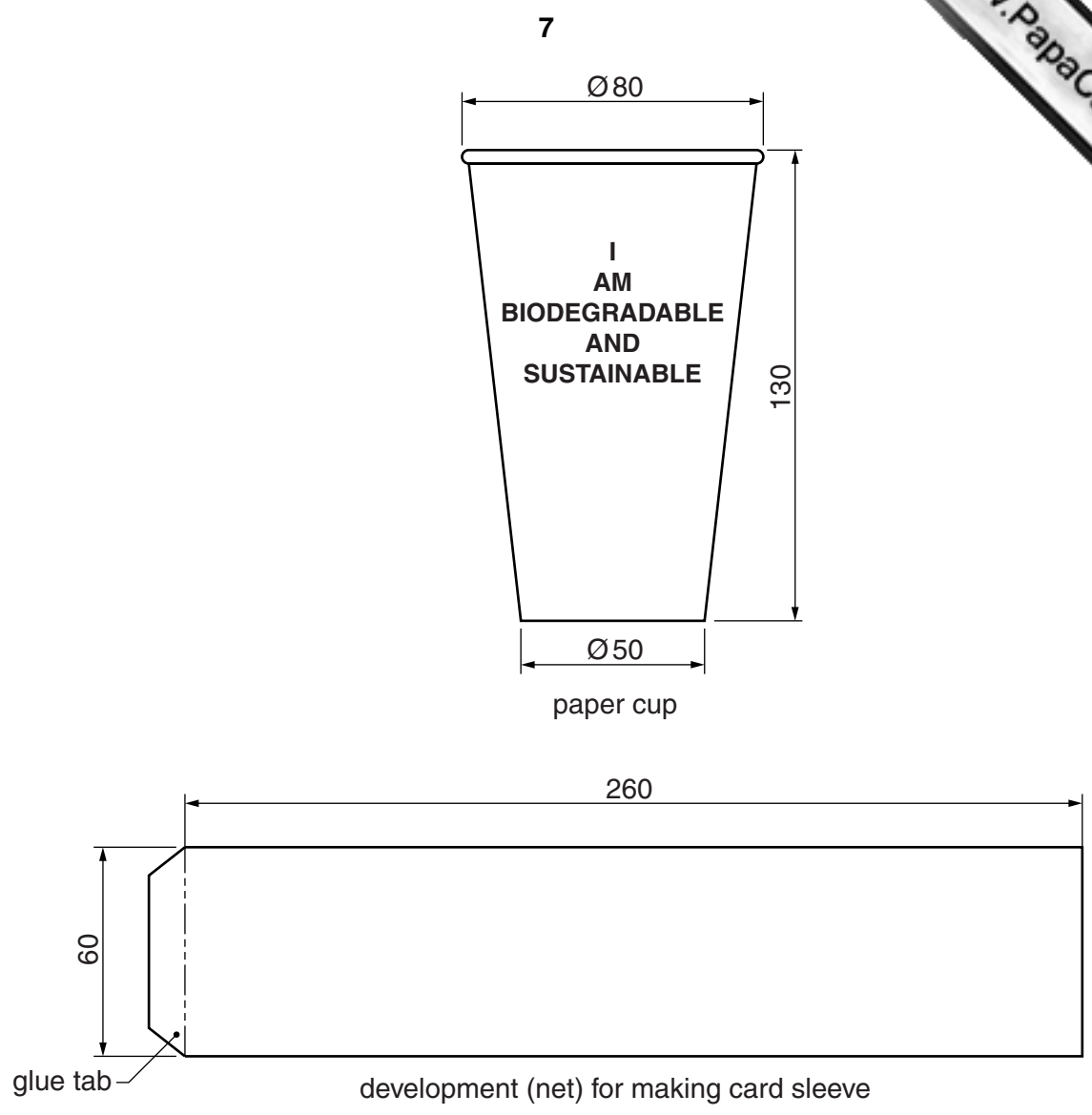

Fig. 4

- 5 Fig. 5 shows a plastic litter bin which will be used in a school playground.
- (a) Explain what the symbol on the bin means.
- (b) Identify and describe **two** problems with the design of the litter bin that make it unsuitable to be used in a school playground. [4]
- (c) Using notes and sketches, explain how the design would need to be changed to overcome the two problems you have identified in (b). [6]
- (d) Discuss how the problems associated with litter, its disposal and recycling are dealt with in public places such as parks, schools and fast food restaurants.

Your answer should:

- (i) analyse the given situation and identify three relevant issues raised by the question; [3]
- (ii) explain why you consider these issues to be relevant; [3]
- (iii) contain specific examples/evidence to support your conclusions. [2]



plastic litter bin
450 diameter × 750 high

Fig. 5

- 6 Fig. 6 shows two products, each of which is used by both an adult and a child at the same time. [1]
- (a) When producing ideas for a new product a designer must understand the importance of ergonomics and be able to interpret and apply appropriate anthropometric data. Explain what is meant by anthropometric data. [4]
- (b) Identify and describe **two** problems with the design of the push-along tractor. [4]
- (c) Using notes and sketches, explain how the design would need to be changed to overcome the two problems you have identified in (b). [6]
- (d) Discuss the ergonomic and safety factors that would need to be considered when designing a pushchair. [2]

Your answer should:

- (i) analyse the given situation and identify three relevant issues raised by the question; [3]
- (ii) explain why you consider these issues to be relevant; [3]
- (iii) contain specific examples/evidence to support your conclusions. [2]



pushchair

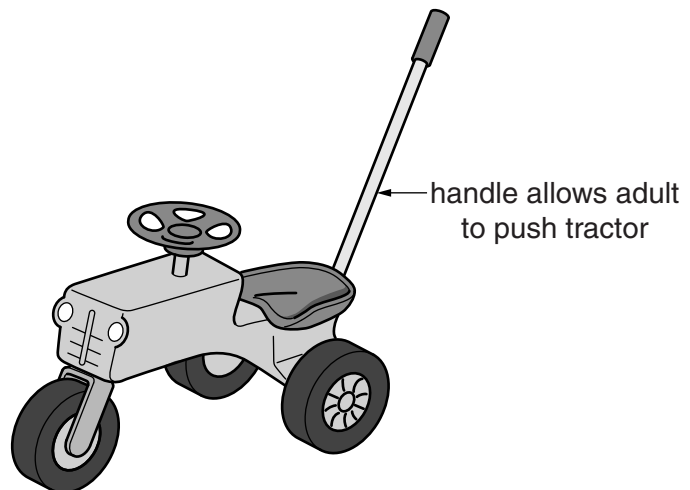

push-along tractor

Fig. 6

Section C

Answer **one** question from this section on the plain A3 paper provided.

You are provided with two sheets of plain A3 paper. You should use **both** sides of the paper. **Each** of the four parts **(a)–(d)** of the question you choose to answer should take up one side of paper.

When you are asked to **develop** a design you must show, using notes and sketches, the development and evaluation of a **range** of ideas into a single design proposal. The design proposal should be annotated to give details about materials, joining methods and important sizes.

- 7 Fig. 7 shows a battery-powered drill, a range of accessories and an incomplete idea for a wooden tool box which will hold them.
- (a)** Using notes and sketches, **develop** a design for the wooden tool box. The design must include a method of keeping the box securely closed. [20]
- (b)** Using notes and sketches, **develop** a design for the interior of the box which will prevent the drill and its accessories moving when the box is carried. [20]
- (c)** Using notes and sketches, **develop** a design which enables the tool box to be carried but keeps both hands free. [20]
- (d)** Produce a pictorial rendered drawing of the complete tool box which shows all of the features that you have designed in **(a)–(c)**.
The tool box must be shown open.
Do not include the drill or its accessories in this drawing. [20]

11

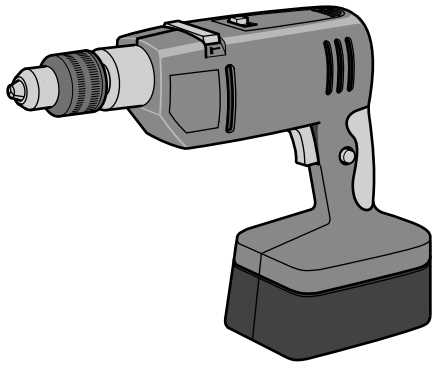

drill: overall size 280 × 280 × 90

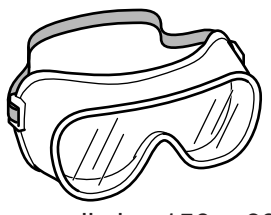

goggles: overall size 150 × 60 × 40



5 drills: one each of the following diameters 4, 6, 8, 10 and 12

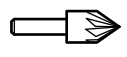

countersink bit

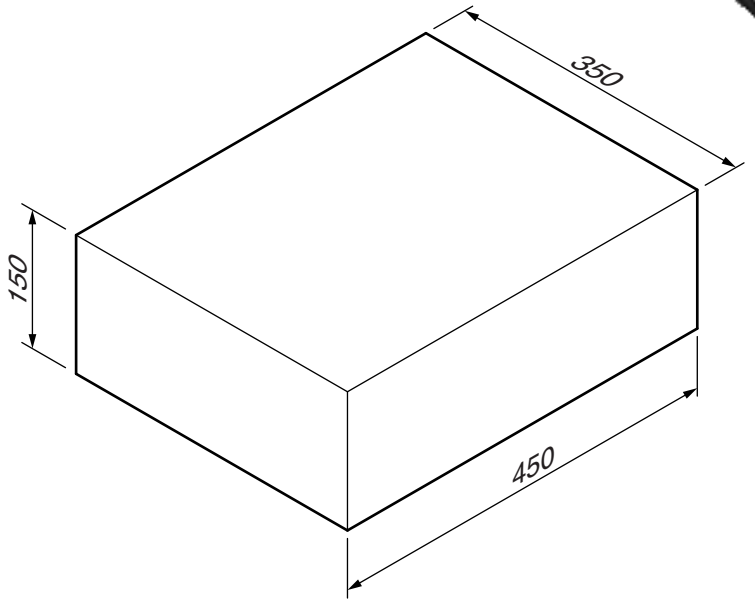

wooden tool box

Fig. 7

- 8 Fig. 8 shows an incomplete idea for a pop-up card. The card will be sent to people who have recently passed their driving test.
- (a) Using notes and sketches, **develop** a design for a pop-up mechanism to go inside the card. The design must reflect the theme of the card. [20]
 - (b) Using notes and sketches, **develop** a design for the message to go inside the card. This will be 'Well done you've passed!' and the lettering should be in a style that reflects the theme of the card. [20]
 - (c) Using notes and sketches, **develop** a design for an envelope to hold the card. The envelope must hold together without the use of glue or other additional materials. [20]
 - (d) Produce a pictorial rendered drawing of the complete card and envelope which shows all of the features that you have designed in (a)–(c). [20]

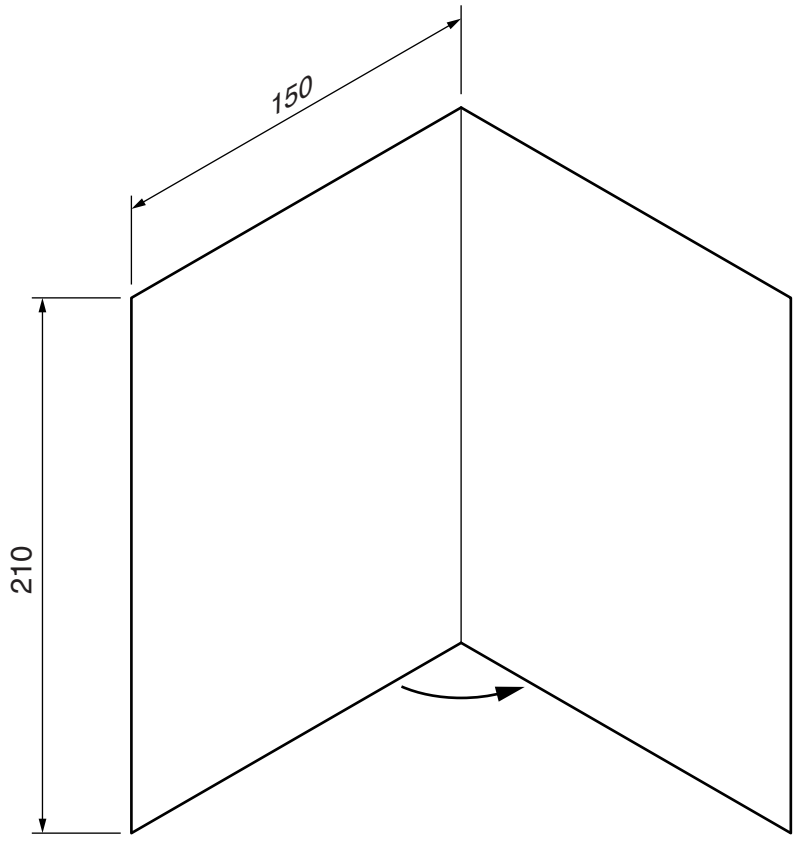

Fig. 8

9 Fig. 9 shows an incomplete idea for a hand-operated teaching aid to help children learn the sequence of traffic lights.

(a) Using notes and sketches, **develop** a design for a mechanism which will be used to represent when the red light is 'on' or 'off'.

The design must not use bulbs, switches, wires, batteries or any other electrical/electronic components. [20]

(b) Using notes and sketches, **develop** a design for the top section of the traffic light. This must house three of the mechanisms that you have designed in (a) (one mechanism for each coloured light). [20]

(c) Using notes and sketches, **develop** a design for a pole and base for the traffic light. It must be possible to disassemble the top section, the pole and the base so that the three parts can be easily stored. [20]

(d) Produce a pictorial rendered drawing of the complete teaching aid which shows all of the features that you have designed in (a)–(c). [20]

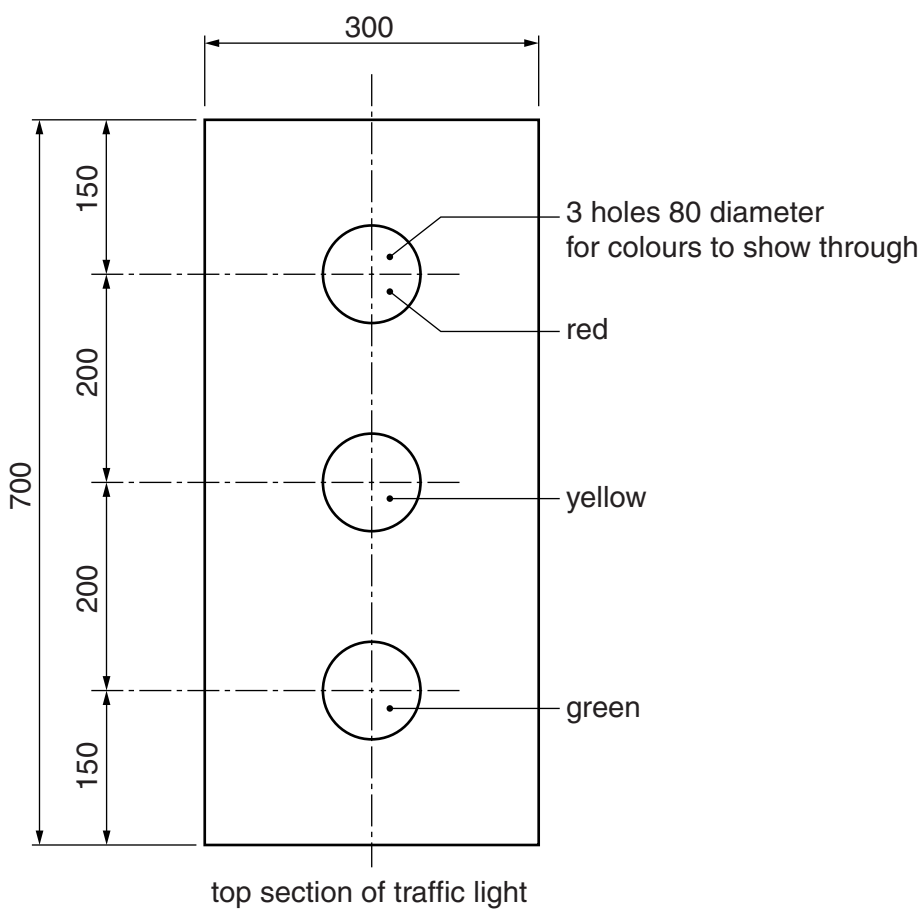

Fig. 9

14
BLANK PAGE

15
BLANK PAGE

Permission to reproduce items where third-party owned material protected by copyright is included has been sought and cleared where possible. Every reasonable effort has been made by the publisher (UCLES) to trace copyright holders, but if any items requiring clearance have unwittingly been included, the publisher will be pleased to make amends at the earliest possible opportunity.

University of Cambridge International Examinations is part of the Cambridge Assessment Group. Cambridge Assessment is the brand name of University of Cambridge Local Examinations Syndicate (UCLES), which is itself a department of the University of Cambridge.