



UNIVERSITY OF CAMBRIDGE INTERNATIONAL EXAMINATIONS  
General Certificate of Education Advanced Subsidiary Level and Advanced Level

---

**DESIGN AND TECHNOLOGY**

9705/33

Paper 3

October/November 2013

3 hours

Additional Materials: Answer Booklet/Paper  
A range of design drawing equipment  
A3 Drawing Paper (5 sheets)



---

**READ THESE INSTRUCTIONS FIRST**

Write your Centre number, candidate number and name on all the work you hand in.

Write in dark blue or black pen.

You may use a soft pencil for any diagrams, graphs or rough working.

Do not use staples, paper clips, highlighters, glue or correction fluid.

**Section A**

Answer **two** questions from **one** of the Parts **A**, **B** or **C**.

**Section B**

Answer **one** question.

All dimensions are in millimetres.

The instruction 'discuss' denotes that you should:

- examine critically the issues raised by the question;
- explain and interpret these issues as appropriate;
- introduce evidence wherever possible to support conclusions of arguments.

At the end of the examination, fasten all your work securely together.

The number of marks is given in brackets [ ] at the end of each question or part question.

---

This document consists of **9** printed pages and **3** blank pages.



Section A

Answer **two** questions from **one** of the Parts A, B or C.

Part A – Product Design

1

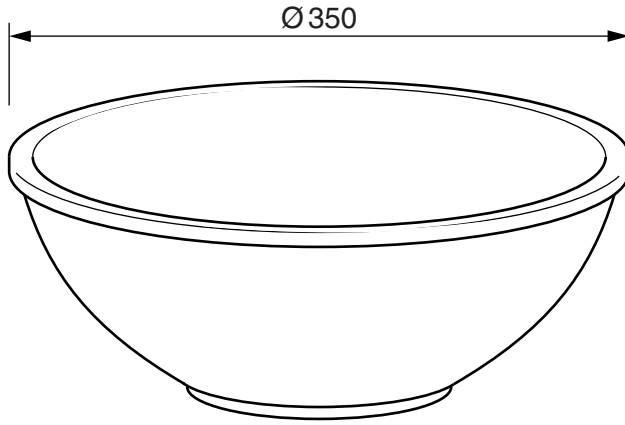

**item:** wooden bowl  
**process:** turning

**item:** chess piece  
**process:** injection moulding

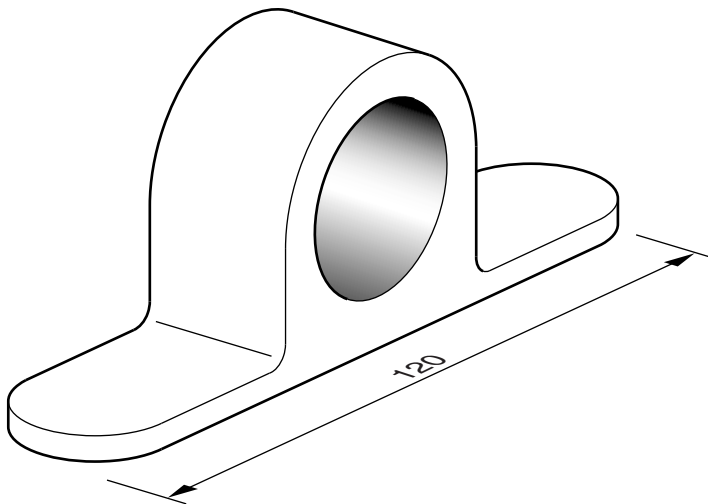
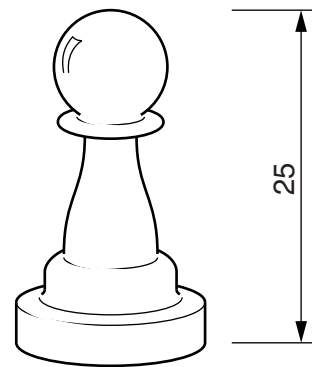

**item:** bearing housing  
**process:** casting

Fig. 1

Choose **two** of the items shown in Fig. 1 and for each:

(a) use notes and sketches to describe the manufacture of the item using the process given; [7 × 2]

(b) explain why the process is particularly suitable for the production of the item. [3 × 2]

3

2 Fig. 2 shows an outline design for a card indexing unit.

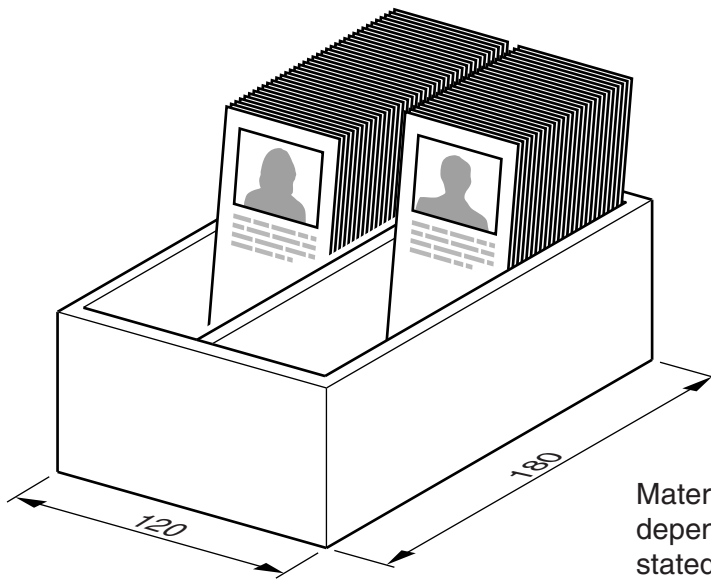

Material thickness is dependent upon the material stated for part (a)

Fig. 2

- (a) State a suitable material for an indexing unit of the type shown in Fig. 2 and give **two** reasons for your choice. [3]
  - (b) Describe, using notes and sketches, how you would make the indexing unit. [9]
  - (c) Explain what changes may be necessary to the design, in the manufacturing method used and in the material selected, if 5000 were required. Use notes and sketches to support your answer. [8]
- 3 Discuss the factors that must be considered when designing products for use in outdoor public spaces. [20]

## Part B – Practical Technology

4 Select **five** materials from the following:

concrete      chipboard      plywood      lead      polythene      ABS  
melamine      polypropylene      aluminium      rubber      mild steel      brass

(a) Name a specific product made predominantly from each of the selected materials. [5]

(b) For each of the products you have selected in part (a), explain in detail why the material used is particularly suitable. [15]

5 Fig. 3 shows a gear train.

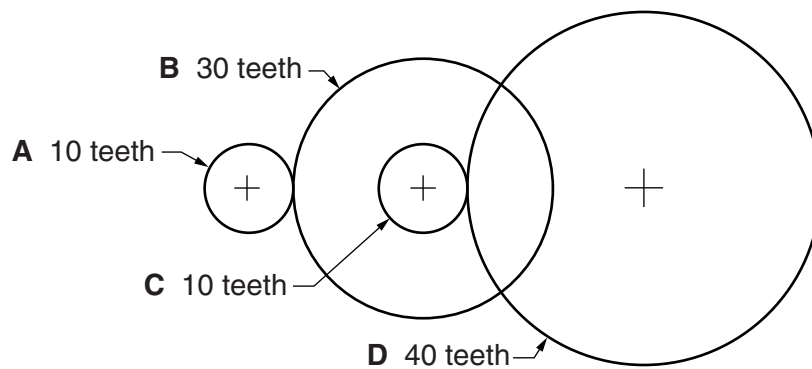

Fig. 3

(a) (i) Gear **A** rotates clockwise, state the direction of rotation of gear **D**. [1]

(ii) Calculate the gear ratio of the compound gear train shown in Fig. 3. [3]

(b) Describe in detail, using examples, **two** different methods of lubricating the moving parts of a machine. [8]

(c) Explain the advantages and disadvantages of friction with reference to the function of products. [8]

6 Structures often require reinforcement so that they are strong enough to perform required tasks.

Select **four** of the following methods of reinforcement:

- lamination;
- braces;
- ribs;
- gussets;
- triangulation.

For each, identify a structure that can be reinforced using the selected method.

Use notes and sketches to explain how the specific structure could be reinforced using the selected method. [4 × 5]

Part C – Graphic Products

- 7 Discuss the factors that affect the 'visual impact' of a product.
- 8 Fig. 4 shows a linkage mechanism.

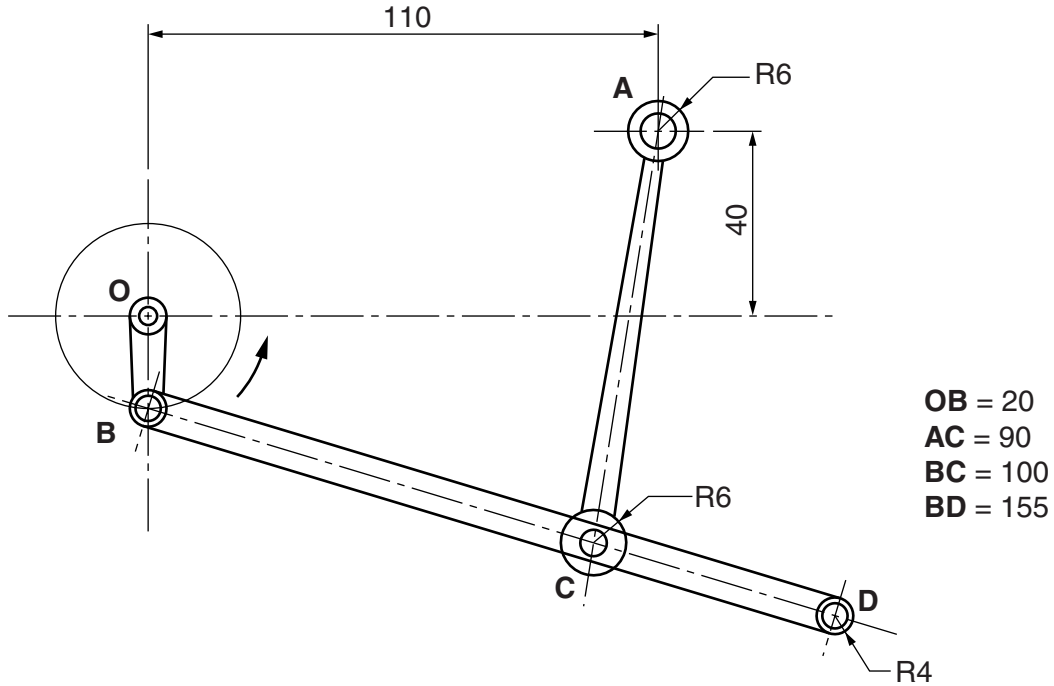

Fig. 4

Linkage **OB** rotates anti-clockwise about the fixed point **O**.  
Linkage **AC** pivots about the fixed point **A**.  
**B** and **C** are pin joints.

- (a) Draw the locus of point **D** for one full rotation of **OB**. [12]
- (b) Draw the profile of a guard to enclose the full mechanism with a clearance of 10mm. [8]

9 Fig. 5 shows the plan of a study area.

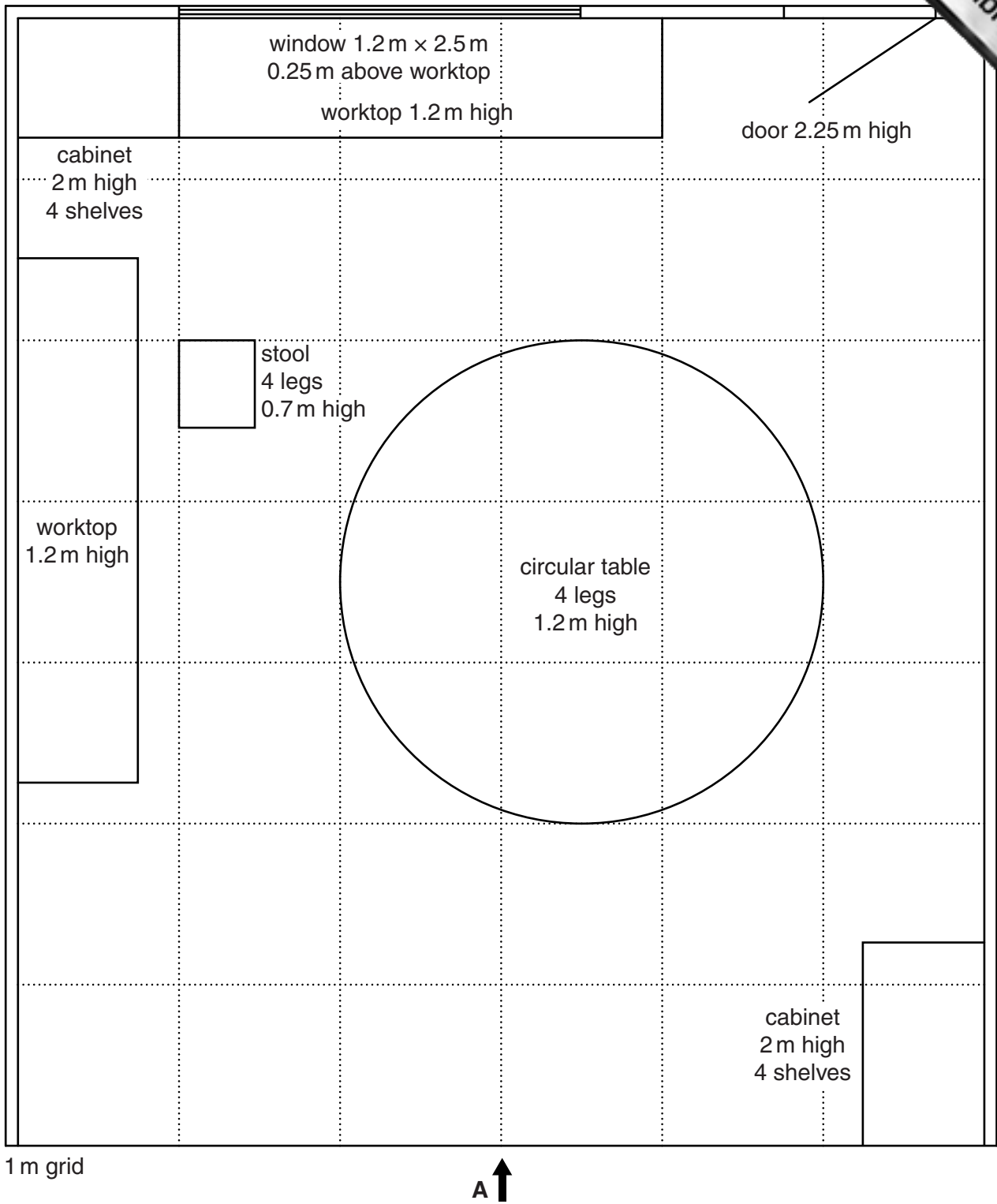

Fig. 5

Draw to an approximate scale, a one-point perspective drawing of the study area viewed from the direction of arrow **A**. [20]

**Section B**

Answer **one** question on the A3 paper provided.

You should approach the design question of your choice in the following manner:

Analysis

Produce an analysis of the given situation/problem, which may be in written or graphical form. [5]

Specification

From the analysis, produce a detailed written specification of the design requirements. Include at least five specification points other than those given in the question. [5]

Exploration

Use bold sketches and brief notes to show your exploration of ideas for a design solution, with reasons for selection. [25]

Development

Show, using bold sketches and notes, the development, reasoning and composition of ideas into a single design proposal. Give details of materials, constructional and other relevant technical details. [25]

Proposed solution

Produce drawings of an appropriate kind to show the complete solution. [15]

Evaluation

Give a written evaluation of the final design solution. [5]

[Total: 80]

- 10 A WildLife Park has a number of rides for adults and children. For health and safety reasons, some rides are designed only for people above a certain height.

You are to design a device that can be used at the entrance to a ride and will clearly let customers know if they meet the minimum height to go on the ride.

The device must:

- be able to be adjusted to provide different height limits ranging from 1.2m to 1.5m;
- reflect the theme of a WildLife Park.

- 11 Your school/college has agreed to take part in a D&T Challenge with other schools and colleges.

You are to design a device that will travel in water from one end of a 25-metre swimming pool to the other in the fastest time.

The device must:

- be mechanically and/or electrically powered (max 2 × 1.5v battery);
- be no larger than 250 × 150 × 150.

Details of the size of a battery and motor are given in Fig. 6.

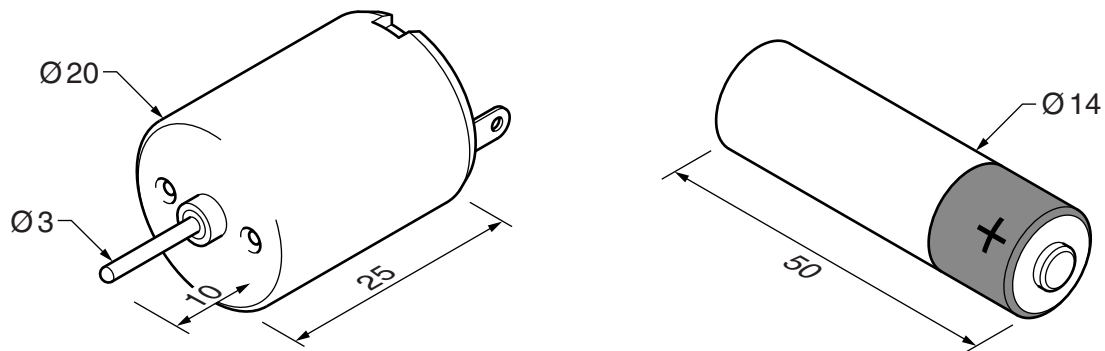

Fig. 6



12 During holiday periods, a large number of tourists visit popular resorts and locations.

You are to design an innovative and exciting free-standing unit that can be sited in a resort, shops and public buildings. It will display information about a resort and places to visit.

The unit must:

- be easily and quickly assembled;
- hold batches of 20 A4 folded leaflets for up to 10 different places to visit.

Details of the A4 leaflet are given in Fig. 7.

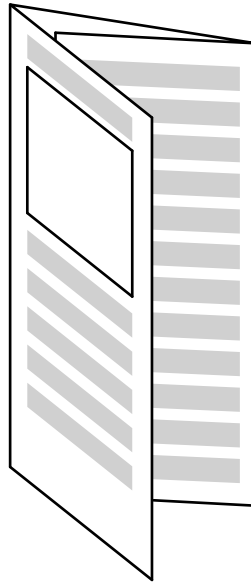

Fig. 7



11  
BLANK PAGE

---

Permission to reproduce items where third-party owned material protected by copyright is included has been sought and cleared where possible. Every reasonable effort has been made by the publisher (UCLES) to trace copyright holders, but if any items requiring clearance have unwittingly been included, the publisher will be pleased to make amends at the earliest possible opportunity.

University of Cambridge International Examinations is part of the Cambridge Assessment Group. Cambridge Assessment is the brand name of University of Cambridge Local Examinations Syndicate (UCLES), which is itself a department of the University of Cambridge.