



Cambridge International Examinations
Cambridge International Advanced Subsidiary and Advanced Level

DESIGN AND TECHNOLOGY

9705/12

Paper 1

October/November 2014

3 hours

Additional Materials: Answer Booklet/A4 Paper
A3 Drawing Paper (2 sheets)
Extra sheets of A3 drawing paper for candidates who have used up both sides of their 2 sheets
A range of design drawing equipment



READ THESE INSTRUCTIONS FIRST

If you have been given an Answer Booklet, follow the instructions on the front cover of the Booklet.
Write your answers and working on the separate Answer Booklet/Paper provided.
Write your name, Centre number and candidate number on all the work you hand in.
Write in dark blue or black pen.
You may use an HB pencil, or coloured pencils/pens as appropriate, for any diagrams, graphs or rough working.
Do not use staples, paper clips, glue or correction fluid.
DO NOT WRITE IN ANY BARCODES.

Section A

Answer **one** question on the Answer Booklet/A4 Paper provided.

Section B

Answer **one** question on the Answer Booklet/A4 Paper provided.

Section C

Answer **one** question on plain A3 paper.
Use **both** sides of the paper.
You may request additional sheets of A3 paper, but only if you have used up both sides of each of the 2 sheets provided.

You are advised to spend **30 minutes** on each of Sections A and B and **2 hours** on Section C.

At the end of the examination, fasten all your work securely together.
The number of marks is given in brackets [] at the end of each question or part question.
All dimensions are in millimetres.

This document consists of **11** printed pages and **1** blank page.

2

Section A

Answer **one** question from this section on the Answer Booklet/A4 paper provided.

- 1 Fig. 1 shows a table, made from 18mm thick plywood, which is to be produced in a school workshop.

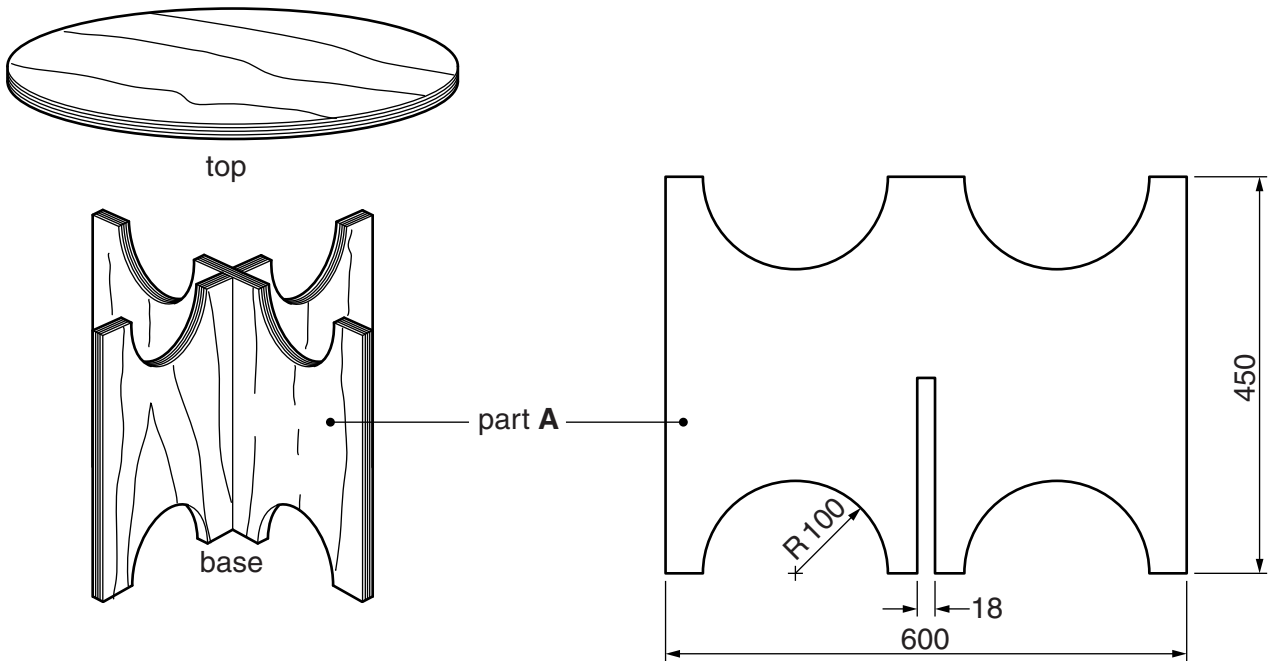

Fig. 1

- (a) Give **two** reasons why the table will be made from plywood rather than solid wood. [2]
- (b) Use notes and sketches to describe:
- (i) how part **A** could be cut out and the edges of the plywood smoothed; [6]
 - (ii) how knock-down (temporary) fittings could be used to join the base to the top; [6]
 - (iii) how a painted finish could be applied to the table. [6]

You must give details about the tools, equipment and processes involved and the safety precautions that have to be undertaken at each stage.

2 Fig. 2 gives details about a cake stand, made from card, which is to be produced in a workshop. The card will be 2000 microns (2 mm) thick.

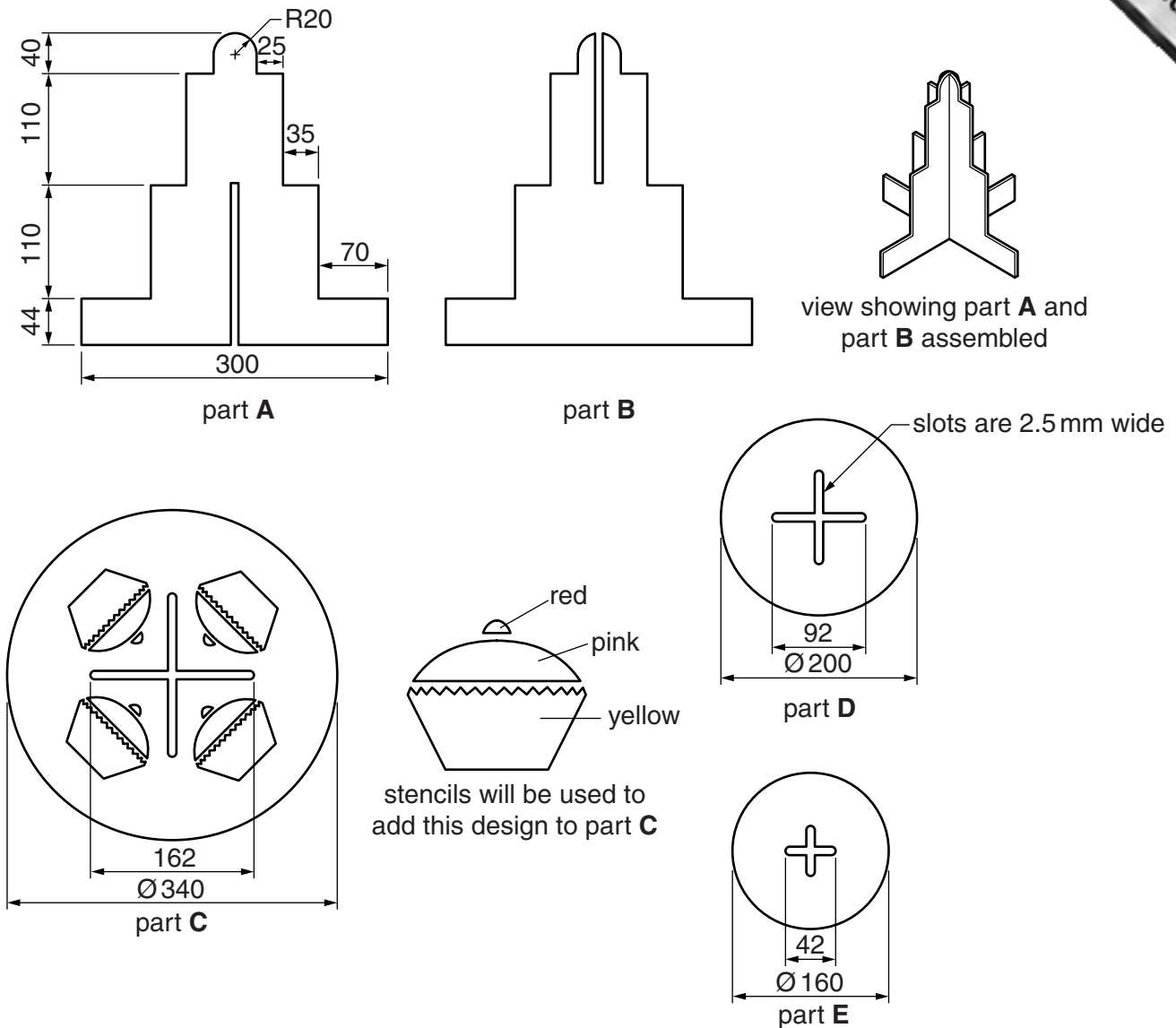

Fig. 2

- (a) Give **two** advantages of producing the cake stand in flat pack form rather than having the five parts permanently joined together. [2]
- (b) Sketch a pictorial (3D) view of the fully assembled cake stand. [6]
- (c) Use notes and sketches to describe:
 - (i) how part **A** could be marked out and cut out; [6]
 - (ii) how stencils could be made and used to add the design to part **C**. [6]

You must give details about the tools, equipment and processes involved and the safety precautions that have to be undertaken at each stage.

- 3 Fig. 3 gives details about a desk tidy, made from plastic, which is to be produced in a workshop. The body of the elephant will be made from a one piece development (net) which includes a base.

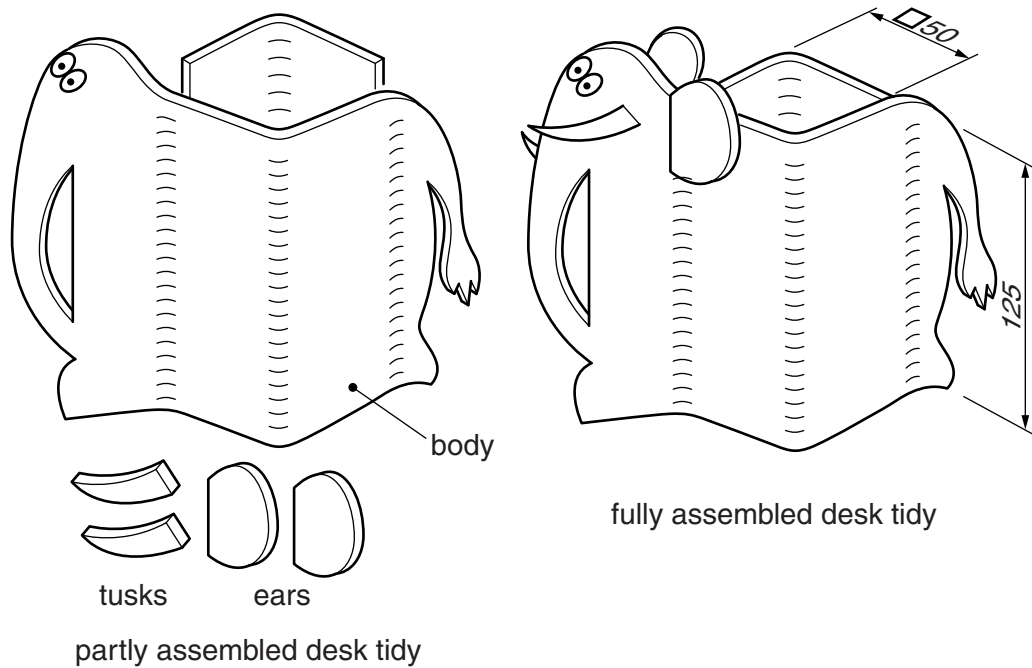

Fig. 3

(a) Name:

- (i) a suitable sheet plastic for making the desk tidy; [1]
 (ii) a suitable glue for joining the ears and tusks of the elephant to the body. [1]

(b) Sketch, to an appropriate scale, the one piece development (net) required to make the body of the elephant. [6]

(c) Use notes and sketches to describe:

- (i) how the one piece development (net) could be cut out and the edges of the sheet plastic smoothed; [6]
 (ii) how the sheet plastic could be bent to the required shape. [6]

You must give details about the tools, equipment and processes involved and the safety precautions that have to be undertaken at each stage.

Section B

Answer **one** question from this section on the Answer Booklet/A4 paper provided.

- 4 Fig. 4 shows a holder to carry drink containers, a range of drink containers and a symbol that frequently appears on drink containers.

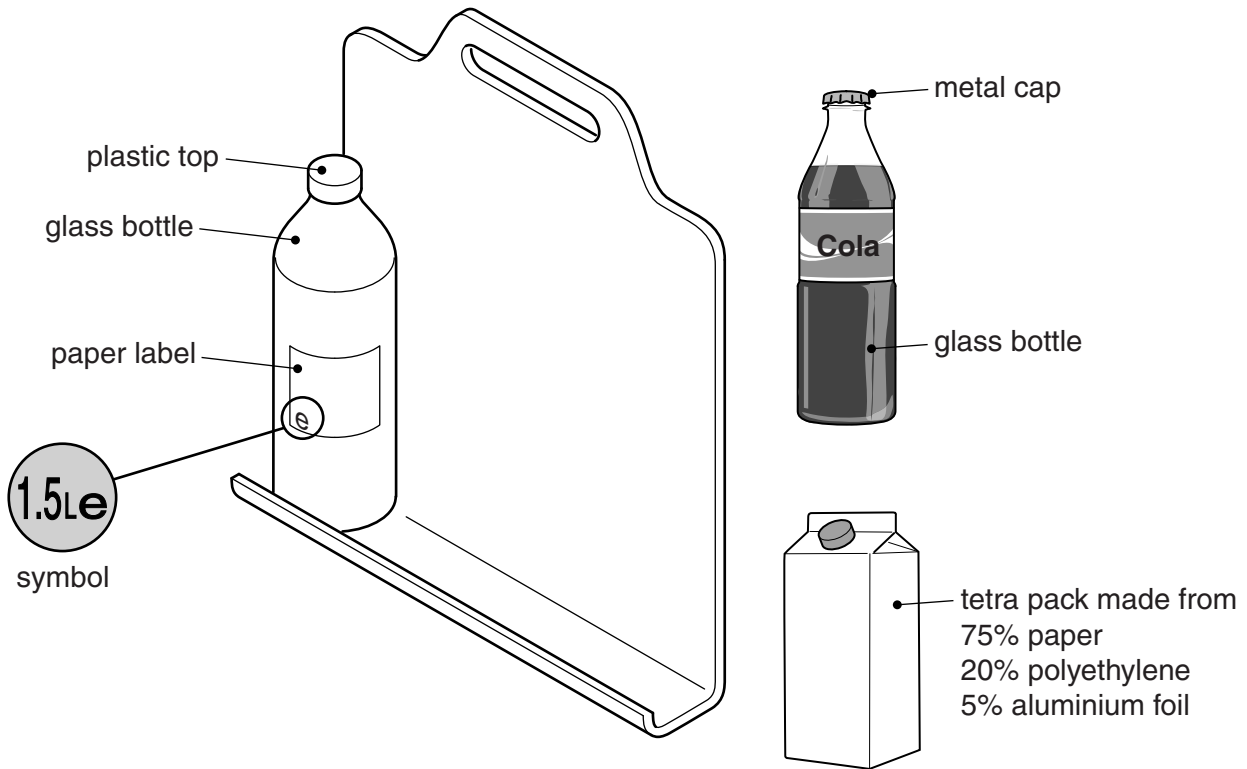

Fig. 4

- (a) Explain what the symbol means. [2]
- (b) Identify and describe **two** problems with the design of the holder. [4]
- (c) Using notes and sketches, explain how the design would need to be changed to overcome the two problems you have identified in (b). [6]
- (d) Each of the drink containers shown in Fig. 4 is made from more than one material. Discuss the problems associated with recycling products that are made from more than one material.

Your answer should:

- (i) analyse the given situation and identify three relevant issues raised by the question; [3]
- (ii) explain why you consider these issues to be relevant; [3]
- (iii) contain specific examples/evidence to support your conclusions. [2]

5 Fig. 5 shows an incomplete design for a child's activity sheet on how to make a pop-up card.

HOW TO MAKE A POP-UP CARD

- 1** Fold a piece of thin card 230 mm × 140 mm in half. Put it aside.

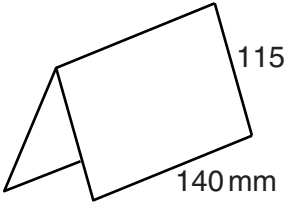

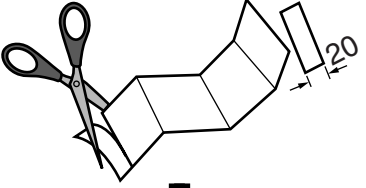
- 2** Cut a strip of thin card 40 mm × 160 mm. Fold the strip in half lengthways. Then fold the strip in half again. Open the strip out and you will have three folds.

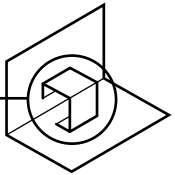

- 3**

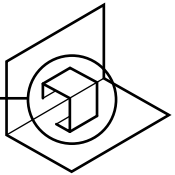

- 4** Fold the strip on the lines to make a 'cube shape'.

- 5**

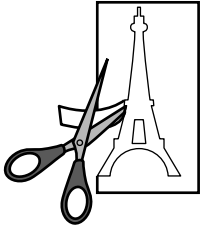
- 6** Fold the strip into a 'cube shape' again. Place it into the centre of your card. Line up the middle fold of the strip with the fold in your card. The ends of the strip should not meet in the middle fold. Make sure your card opens and closes easily.

- 7** Take a piece of thin card 40 mm × 70 mm and draw one of the famous buildings in Paris. Colour and cut out your design.

- 8** Glue your design to one side of your 'cube shape'. When your card closes the design should be completely inside your card.

- 9** Add a message to the front of your card.



Fig. 5

- (a) Explain the purpose of the design feature shown at X. [1]
- (b) There are problems with the text and diagrams.
Identify and describe **two** problems with the instructions given on the activity sheet.
- (c) Using notes and sketches, explain how the instructions would need to be changed to overcome the two problems that you have identified in (b). [6]
- (d) The instructions shown in Fig. 5 use a combination of text and diagrams. Discuss the benefits of having instructions in this form rather than using just text or just diagrams.

Your answer should:

- (i) analyse the given situation and identify three relevant issues raised by the question; [3]
- (ii) explain why you consider these issues to be relevant; [3]
- (iii) contain specific examples/evidence to support your conclusions. [2]

8

6 Fig. 6 shows a power hacksaw.

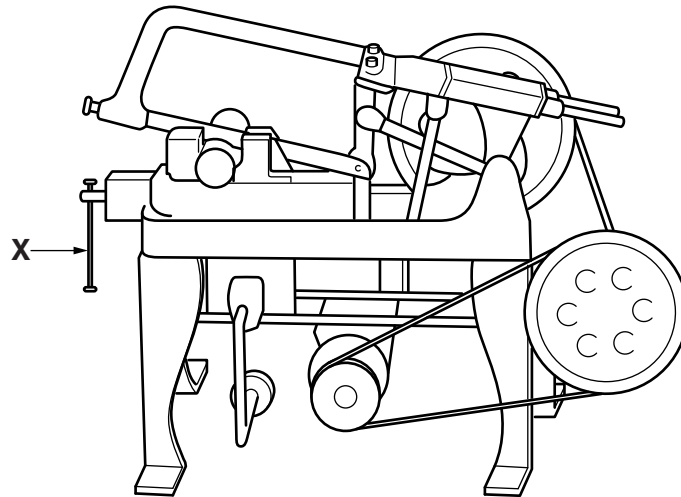

Fig. 6

- (a) Explain the purpose of the design feature shown at **X**. [2]
- (b) Identify and describe **two** problems with the design of the power hacksaw that make it unsafe to use. [4]
- (c) Using notes and sketches, explain how the design would need to be changed to overcome the two problems you have identified in (b). [6]
- (d) Discuss the safety checks and other risk assessments that would need to be carried out before using electrically powered machines in a school workshop.

Your answer should:

- (i) analyse the given situation and identify three relevant issues raised by the question; [3]
- (ii) explain why you consider these issues to be relevant; [3]
- (iii) contain specific examples/evidence to support your conclusions. [2]

Section C

Answer **one** question from this section on the plain A3 paper provided.

You are provided with two sheets of plain A3 paper. You should use **both** sides of the paper. **Each** of the four parts (a) – (d) of the question you choose to answer should take up one side of paper.

When you are asked to **develop** a design you must show, using notes and sketches, the development and evaluation of a **range** of ideas into a single solution. The design proposal should be annotated to give details about materials, joining methods and important sizes.

7 Fig. 7 shows an incomplete idea for a cardboard box to package a skateboard.

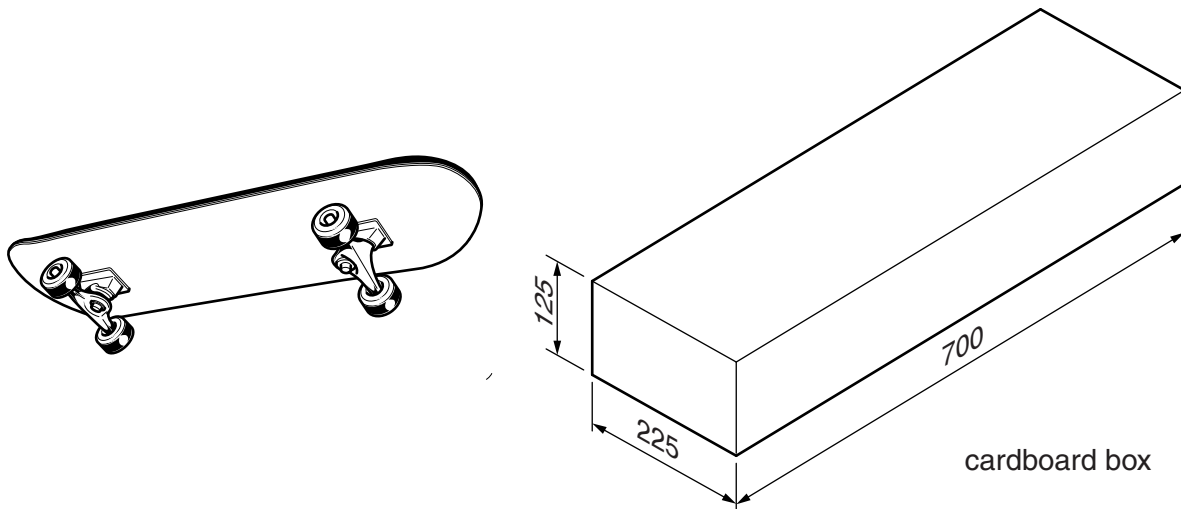

Fig. 7

- (a) Using notes and sketches, **develop** a design for the cardboard box. The box must be made from a one piece development (net) and have no more than one glue joint. It must be possible to open and securely close the box. [20]
- (b) Using notes and sketches, **develop** a design which enables the box to be easily carried. [20]
- (c) Using notes and sketches, **develop** a design for the lettering to go on the box. The company's name is '**Wild Wheels**' and the lettering should be in a style that reflects the product being packaged. [20]
- (d) Produce a pictorial rendered drawing of the complete cardboard box which shows all of the features that you have designed in (a) – (c). The drawing must show the box open. [20]

10

- 8 Fig. 8 shows an incomplete idea for a child's swing. The frame for the swing will be 1

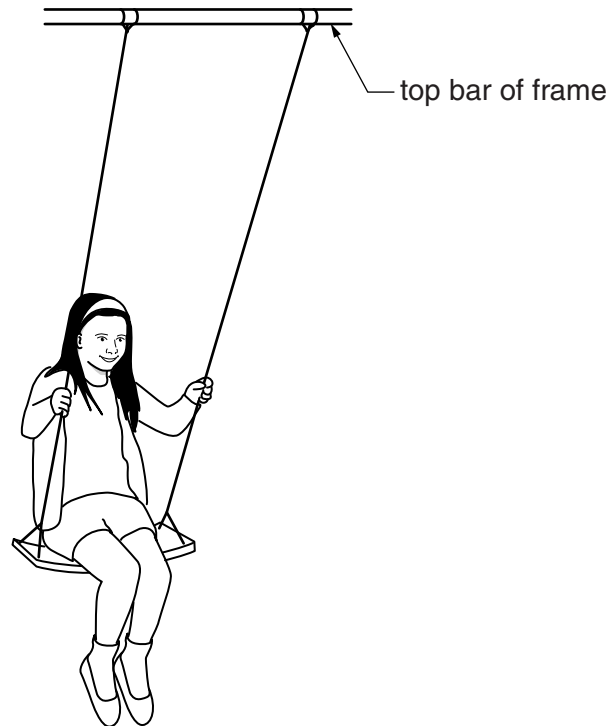

Fig. 8

- (a) Using notes and sketches, **develop** a design for a seat. The design must include features which prevent a child under the age of four from falling off the seat. [20]
- (b) Using notes and sketches, **develop** a design for a stable frame from which the seat will hang. It must be easy to dismantle the frame into sections no longer than 1000mm. The design must include a method of securing the frame to the ground. [20]
- (c) Using notes and sketches, **develop** a design which enables the seat to be attached to and easily removed from the frame. [20]
- (d) Produce a pictorial rendered drawing of the complete swing which shows all of the features that you have designed in (a) – (c). [20]

9 Fig. 9 shows an incomplete idea for a child's hand held mechanical toy.

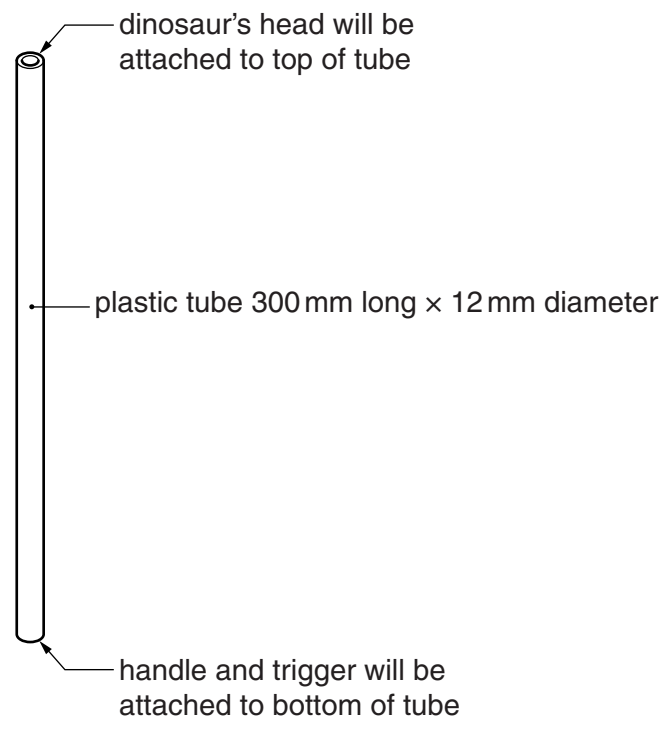

Fig. 9

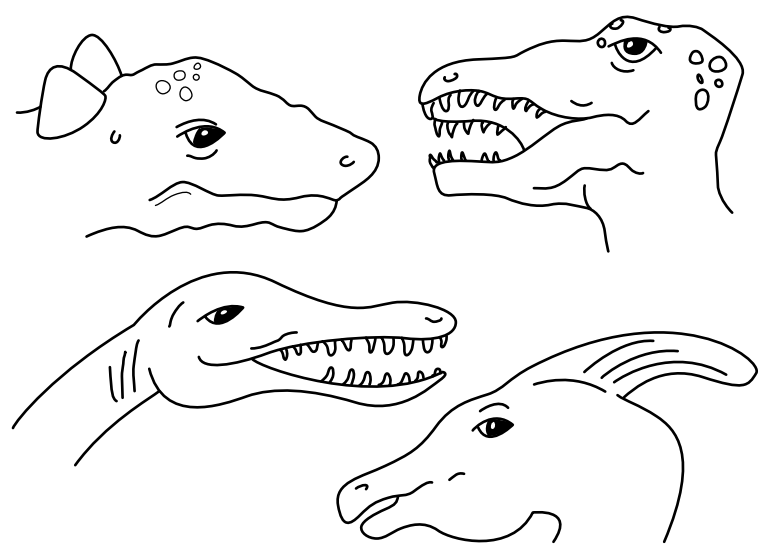

Fig. 10

- (a) Using notes and sketches, **develop** a design for the dinosaur's head that has a mouth which will open and close.
The images shown in Fig. 10 have been provided to help you with your design work. [20]
- (b) Using notes and sketches, **develop** a design for a handle which will enable a child to hold the toy. [20]
- (c) Using notes and sketches, **develop** a design for a trigger operated mechanism that will open the dinosaur's mouth when the trigger is squeezed and close it when the trigger is released. [20]
- (d) Produce a pictorial rendered drawing of the complete mechanical toy which shows all of the features that you have designed in (a) – (c). The dinosaur's mouth should be shown open. [20]

Permission to reproduce items where third-party owned material protected by copyright is included has been sought and cleared where possible. Every reasonable effort has been made by the publisher (UCLES) to trace copyright holders, but if any items requiring clearance have unwittingly been included, the publisher will be pleased to make amends at the earliest possible opportunity.

Cambridge International Examinations is part of the Cambridge Assessment Group. Cambridge Assessment is the brand name of University of Cambridge Local Examinations Syndicate (UCLES), which is itself a department of the University of Cambridge.