

Cambridge  
International  
AS & A Level

**Cambridge International Examinations**  
Cambridge International Advanced Subsidiary and Advanced Level

CANDIDATE  
NAME

CENTRE  
NUMBER

--	--	--	--	--

CANDIDATE  
NUMBER

--	--	--	--

**DESIGN AND TECHNOLOGY**

**9705/12**

Paper 1

**October/November 2015**

**3 hours**

Additional Materials:

Answer Booklet/A4 Paper

A3 Drawing Paper (2 sheets)

Extra sheets of A3 drawing paper for candidates who have used up both sides of their 2 sheets

A range of design drawing equipment

**READ THESE INSTRUCTIONS FIRST**

If you have been given an Answer Booklet, follow the instructions on the front cover of the Booklet.

Write your answers and working on the separate Answer Booklet/Paper provided.

Write your name, Centre number and candidate number on all the work you hand in.

Write in dark blue or black pen.

You may use an HB pencil, or coloured pencils/pens as appropriate, for any diagrams, graphs or rough working.

Do not use staples, paper clips, glue or correction fluid.

**DO NOT WRITE IN ANY BARCODES.**

**Section A**

Answer **one** question on the Answer Booklet/A4 Paper provided.

**Section B**

Answer **one** question on the Answer Booklet/A4 Paper provided.

**Section C**

Answer **one** question on plain A3 paper.

Use **both** sides of the paper.

You may request additional sheets of A3 paper, but only if you have used up both sides of each of the 2 sheets provided.

You are advised to spend **30 minutes** on each of Sections A and B and **2 hours** on Section C.

At the end of the examination, fasten all your work securely together.

The number of marks is given in brackets [ ] at the end of each question or part question.

All dimensions are in millimetres.

This document consists of **11** printed pages and **1** blank page.

2

## Section A

Answer **one** question from this section on the Answer Booklet/A4 paper provided.

- 1 Fig. 1 shows a chair made from one piece of bent plywood.

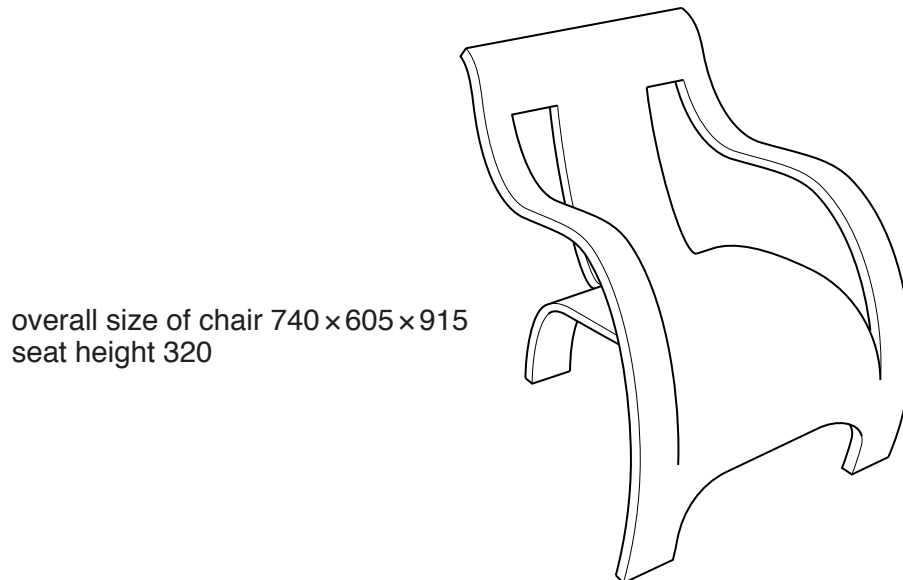

Fig. 1

- (a) The chair will be manufactured using batch production.  
Explain what is meant by batch production. [2]
- (b) Draw, to a suitable size, the outline shape that would need to be cut from a sheet of plywood to make the chair. [6]

Fig. 2 shows details about a table which is to be made in a school workshop.

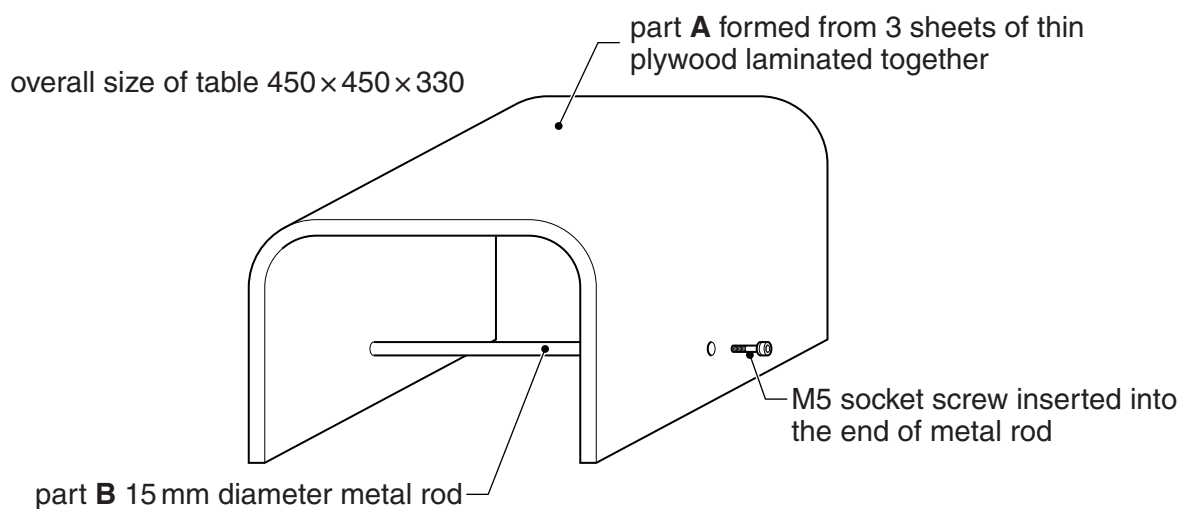

Fig. 2

3

(c) Use notes and sketches to describe:

(i) how three pieces of thin plywood could be laminated to make part **A**; [6]

(ii) how the threaded hole could be made in the end of part **B**. [6]

You must give details about the tools, equipment and processes involved and the safety precautions that have to be undertaken at each stage.

- 2 Fig. 3 gives details about a box made from card. Several of these boxes will be made in a school workshop.

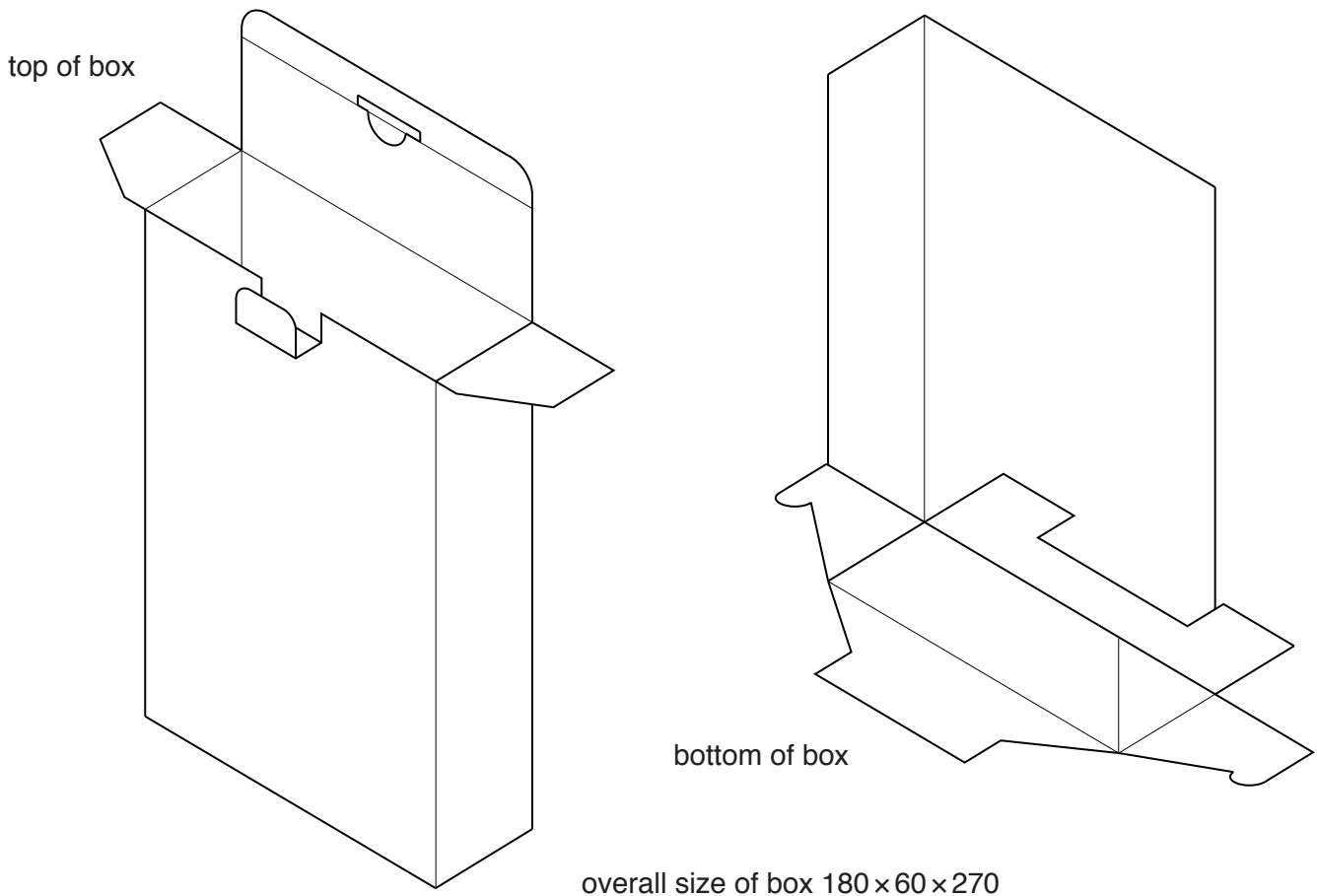

**Fig. 3**

(a) Use notes and sketches to describe:

- (i) stage by stage how the top of the box should be closed; [6]
- (ii) stage by stage how the bottom of the box should be closed; [6]
- (iii) how a template could be made, from thin plastic, and used to mark out the development (net), including fold lines required to make the box. [6]

(b) Give **two** reasons why thin plastic has been chosen for the template rather than card. [2]

You must give details about the tools, equipment and processes involved and the safety precautions that have to be undertaken at each stage.

3 Fig. 4 gives details about a laptop support which is to be made in a school workshop.

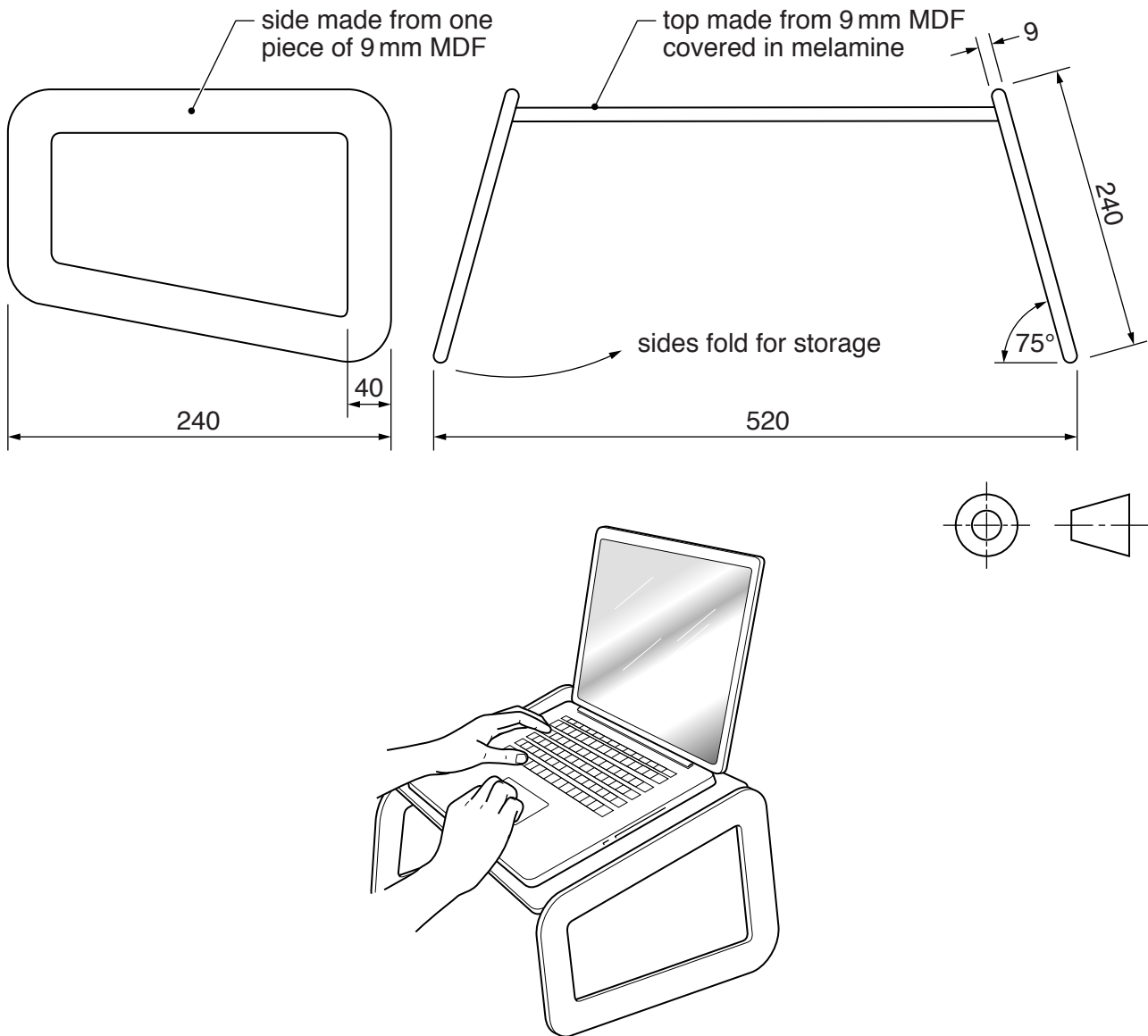

(a) Use notes and sketches to describe:

- (i) how one side could be cut out and the edges of the MDF rounded; [6]
- (ii) how a sheet of melamine plastic could be attached to the top surface and the edges of the top angled at 15 degrees; [6]
- (iii) how the sides and the top could be joined together using hinges. [6]

(b) Give **two** reasons why melamine plastic has been attached to the top. [2]

You must give details about the tools, equipment and processes involved and the safety precautions that have to be undertaken at each stage.

## Section B

Answer **one** question from this section on the Answer Booklet/A4 paper provided.

- 4 Fig. 5 shows the frame of a junior hacksaw and a jig which is to be used to bend a length of 6 mm diameter mild steel rod to the shape required for the frame.

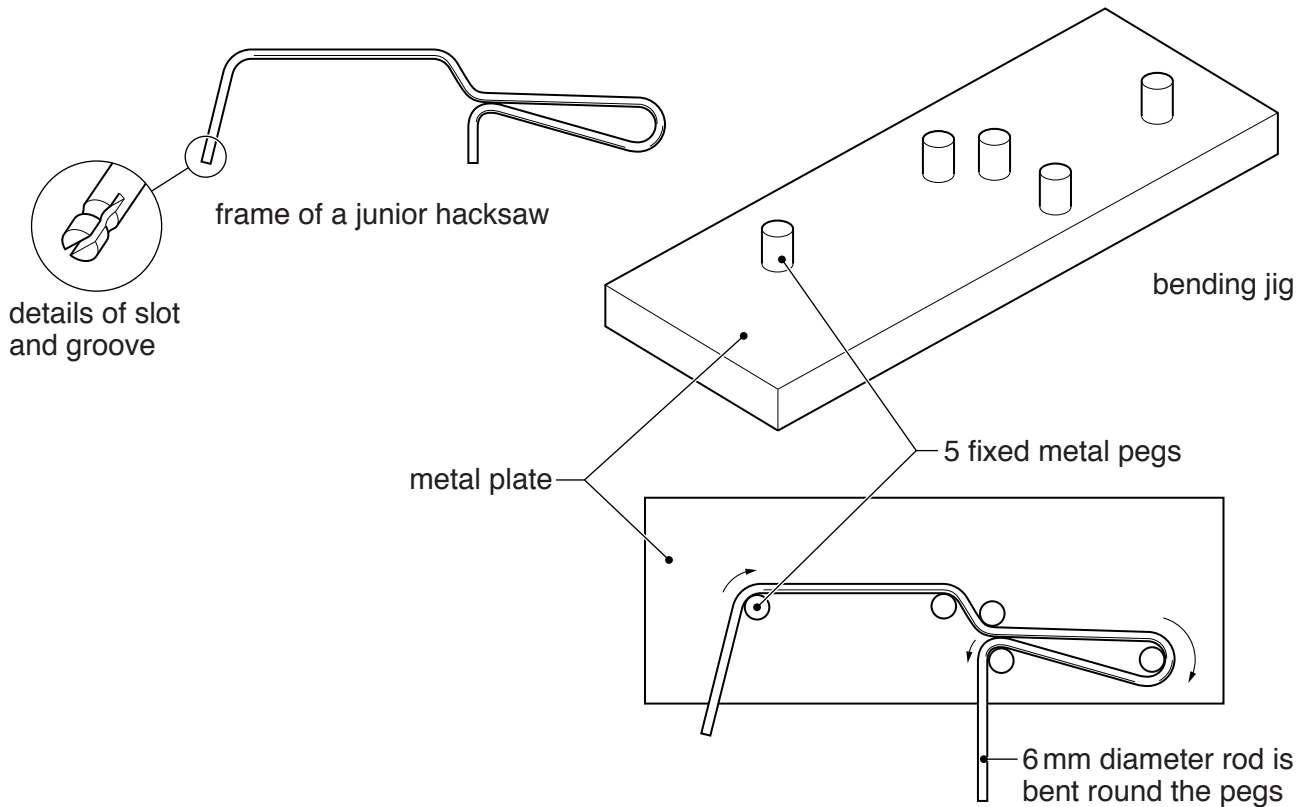

Fig. 5

- (a) Use notes and a sketch to explain the function of the slot and groove in the end of the frame. [2]
- (b) Identify and describe **two** problems with the design of the bending jig. [4]
- (c) Using notes and sketches, explain how the design would need to be changed to overcome the two problems you have identified in (b). [6]
- (d) Heat is often used during the manufacture of products made from metal. Discuss how heat treatments can change the properties of metals.

Your answer should:

- (i) analyse the given situation and identify **three** relevant issues raised by the question; [3]
- (ii) explain why you consider these issues to be relevant; [3]
- (iii) contain specific examples/evidence to support your conclusions. [2]

- 5 Fig. 6 gives details about packaging to hold a CD and two information cards. The packaging consists of a box, lid and insert all made from 500 microns (0.5mm) thick card. A clear plastic sticker is stuck on the front of the assembled packaging.

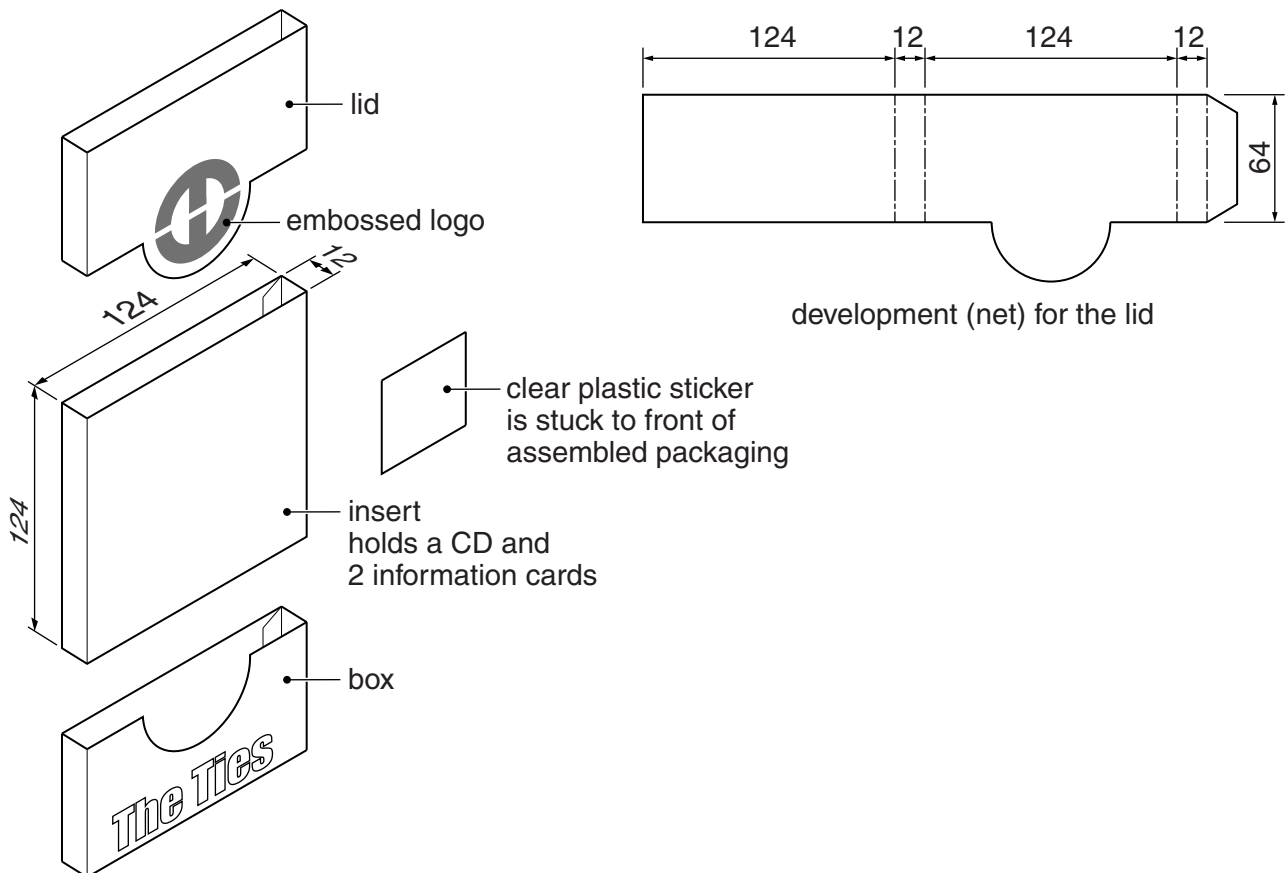

**Fig. 6**

- (a) Explain the function of the clear plastic sticker. [2]
- (b) Identify and describe **two** problems with the design of the development (net) for the lid. [4]
- (c) Using notes and sketches, explain how the design would need to be changed to overcome the two problems you have identified in (b). [6]
- (d) The packaging has an embossed logo. Discuss how surface treatments and finishes can improve the sales of a product.

Your answer should:

- (i) analyse the given situation and identify **three** relevant issues raised by the question; [3]
- (ii) explain why you consider these issues to be relevant; [3]
- (iii) contain specific examples/evidence to support your conclusions. [2]

6 Fig. 7 shows a blow moulding die used in the manufacture of screw top plastic bottles.

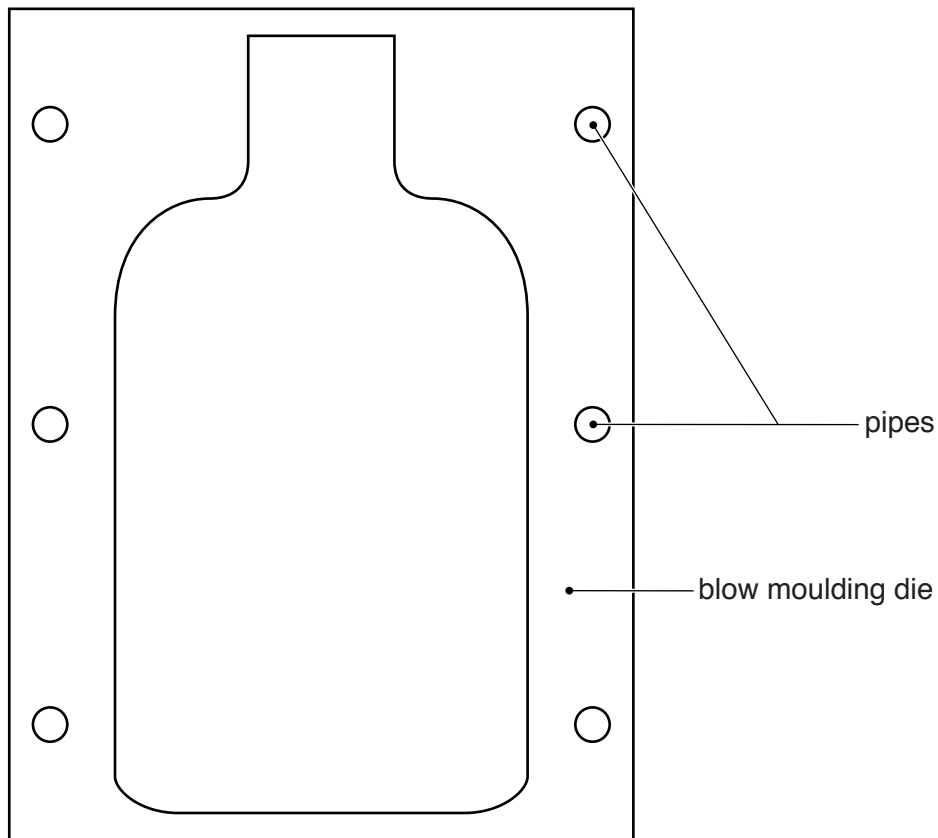

Fig. 7

- (a) Explain the purpose of the pipes that run through the die. [2]
- (b) Identify and describe **two** problems with the design of the die. [4]
- (c) Using notes and sketches, explain how the design would need to be changed to overcome the two problems you have identified in (b). [6]
- (d) Discuss the benefits to the manufacturer of using processes such as blow moulding and injection moulding in the mass production of products.

Your answer should:

- (i) analyse the given situation and identify **three** relevant issues raised by the question; [3]
- (ii) explain why you consider these issues to be relevant; [3]
- (iii) contain specific examples/evidence to support your conclusions. [2]



## Section C

Answer **one** question from this section on the plain A3 paper provided.

You are provided with two sheets of plain A3 paper. You should use **both** sides of the paper. **Each** of the four parts (a)–(d) of the question you choose to answer should take up one side of paper.

When you are asked to **develop** a design you must show, using notes and sketches, the development and evaluation of a **range** of ideas into a single design proposal. The design proposal should be annotated to give details about materials, joining methods and important sizes.

7 Fig. 8 shows an incomplete idea for a floor lamp.

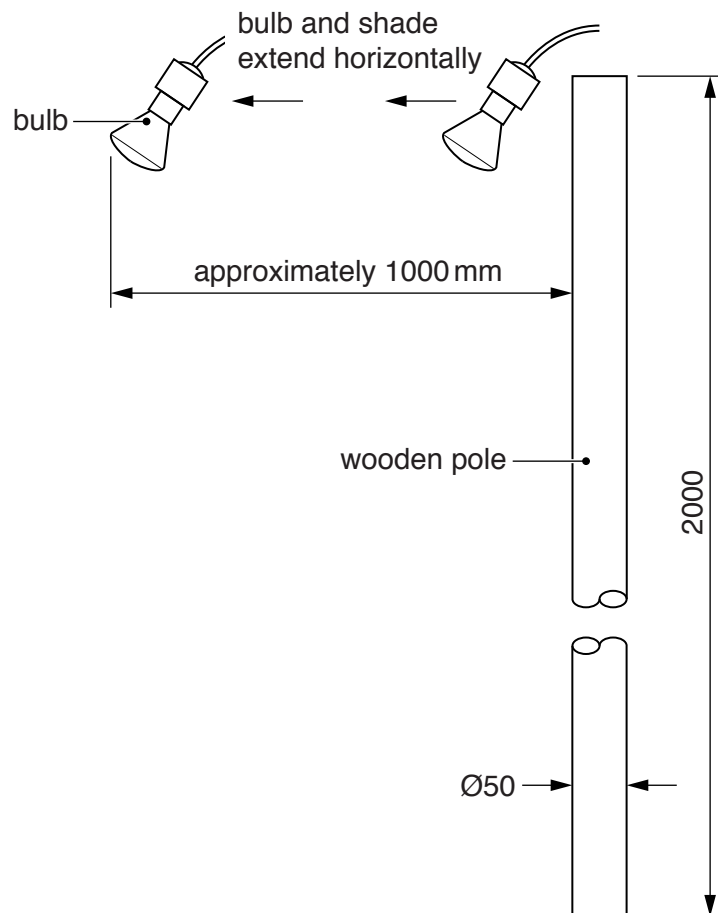

Fig. 8

- (a) Using notes and sketches, **develop** a design for a mechanism which allows the bulb and shade to extend horizontally. This must include a method of joining the mechanism to the wooden pole. [20]
- (b) Using notes and sketches, **develop** a design for a lamp shade. This must include a method of joining the lamp shade to the mechanism that you have designed in (a). [20]
- (c) Using notes and sketches, **develop** a design for a stable base for the floor lamp. This must include a method of joining the base to the wooden pole. [20]
- (d) Produce a pictorial rendered drawing of the complete floor lamp which shows all of the features that you have designed in (a)–(c). [20]

- 8 Fig. 9 shows four items of cosmetics and an incomplete idea for the packaging to hold them. The packaging consists of three parts:
- a regular hexagonal box;
  - a tray that can either slide or lift out of the box;
  - a card insert that fits in the tray and prevents the cosmetics from moving around.
- The three parts will be made from card.

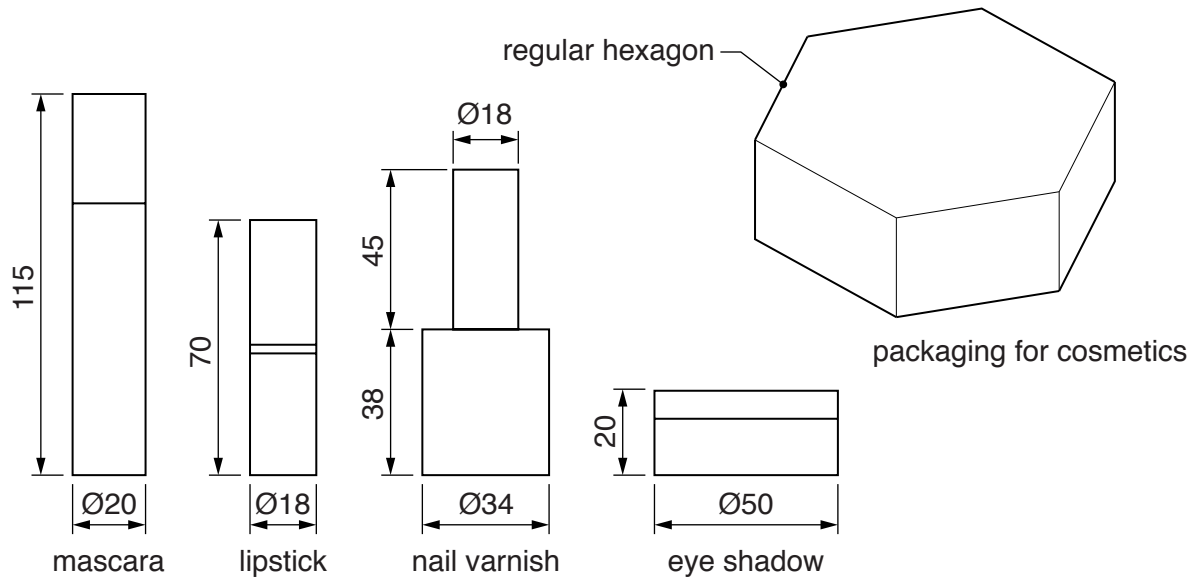
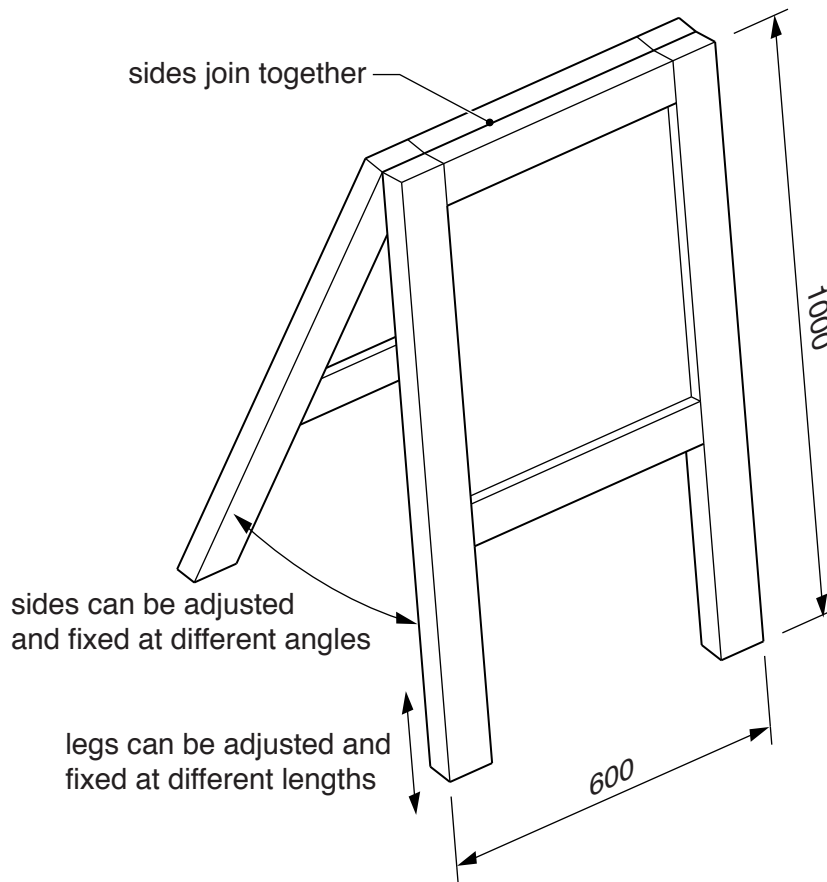

Fig. 9

- (a) Using notes and sketches, **develop** designs for the card tray and the card insert. Your design work must include details of the one piece developments (nets) required to make the tray and the insert. [20]
- (b) Using notes and sketches, **develop** a design for the hexagonal box. The design must be made from a one piece development (net) and include four windows so that the cosmetics can be seen when in the closed packaging. Your design work must include details of the one piece development required to make the box. [20]
- (c) Using notes and sketches, **develop** a design for the lettering to go on the packaging. The name of the cosmetics is '**Moonbeams and Starlight**' and the lettering should be in a style that reflects the name. [20]
- (d) Produce an exploded pictorial rendered drawing of the complete packaging which shows all of the features that you have designed in (a)–(c). Do **not** include the cosmetics in this drawing. [20]

- 9 Fig. 10 shows an incomplete design for a drawing and painting easel.



**Fig. 10**

- (a) Using notes and sketches, **develop** a design which allows the legs to be adjusted and fixed at different lengths between 1000 mm and 1500 mm. [20]
- (b) Using notes and sketches, **develop** designs which join together the two sides of the easel and allows them to be adjusted and fixed at different angles. [20]
- (c) Using notes and sketches, **develop** a design for a detachable tray to hold pens, pencils, pots of paint etc. which could be easily fixed to and removed from the easel. [20]
- (d) Produce a pictorial rendered drawing of the complete easel which shows all of the features that you have designed in (a)–(c). [20]

**BLANK PAGE**

---

Permission to reproduce items where third-party owned material protected by copyright is included has been sought and cleared where possible. Every reasonable effort has been made by the publisher (UCLES) to trace copyright holders, but if any items requiring clearance have unwittingly been included, the publisher will be pleased to make amends at the earliest possible opportunity.

To avoid the issue of disclosure of answer-related information to candidates, all copyright acknowledgements are reproduced online in the Cambridge International Examinations Copyright Acknowledgements Booklet. This is produced for each series of examinations and is freely available to download at [www.cie.org.uk](http://www.cie.org.uk) after the live examination series.

Cambridge International Examinations is part of the Cambridge Assessment Group. Cambridge Assessment is the brand name of University of Cambridge Local Examinations Syndicate (UCLES), which is itself a department of the University of Cambridge.