

DESIGN AND TECHNOLOGY**9705/31**

Paper 3

October/November 2015**3 hours**

Additional Materials: Answer Booklet/Paper
 A range of design drawing equipment
 A3 Drawing Paper (5 sheets)

READ THESE INSTRUCTIONS FIRST

Write your Centre number, candidate number and name on all the work you hand in.

Write in dark blue or black pen.

You may use an HB pencil for any diagrams, graphs or rough working.

Do not use staples, paper clips, glue or correction fluid.

DO NOT WRITE IN ANY BARCODES.

Section A

Answer **two** questions from **one** of the Parts **A**, **B** or **C**.

Section B

Answer **one** question.

All dimensions are in millimetres.

The instruction 'discuss' denotes that you should:

- examine critically the issues raised by the question;
- explain and interpret these issues as appropriate;
- introduce evidence wherever possible to support conclusions of arguments.

At the end of the examination, fasten all your work securely together.

The number of marks is given in brackets [] at the end of each question or part question.

This document consists of **10** printed pages and **2** blank pages.

2

Section A

Answer **two** questions from **one** of the Parts **A**, **B** or **C**.

Part A – Product Design

1 Fig. 1 shows a soap dispenser bracket.

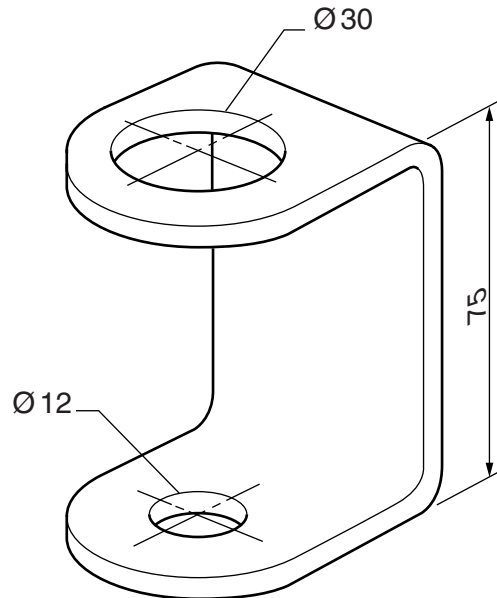

Fig. 1

- (a) State a suitable material for a soap dispenser bracket of the type shown in Fig. 1 and give **two** reasons for your choice. [3]
- (b) Describe, using notes and sketches, how you would make the soap dispenser bracket in a school workshop. [9]
- (c) Explain what changes may be necessary to the design, the manufacturing method used and the material selected, if 5000 soap dispenser brackets were required. Use notes and sketches to support your answer. [8]
- 2 Discuss the implications of market-pull on the design and manufacture of products. [20]

3

3

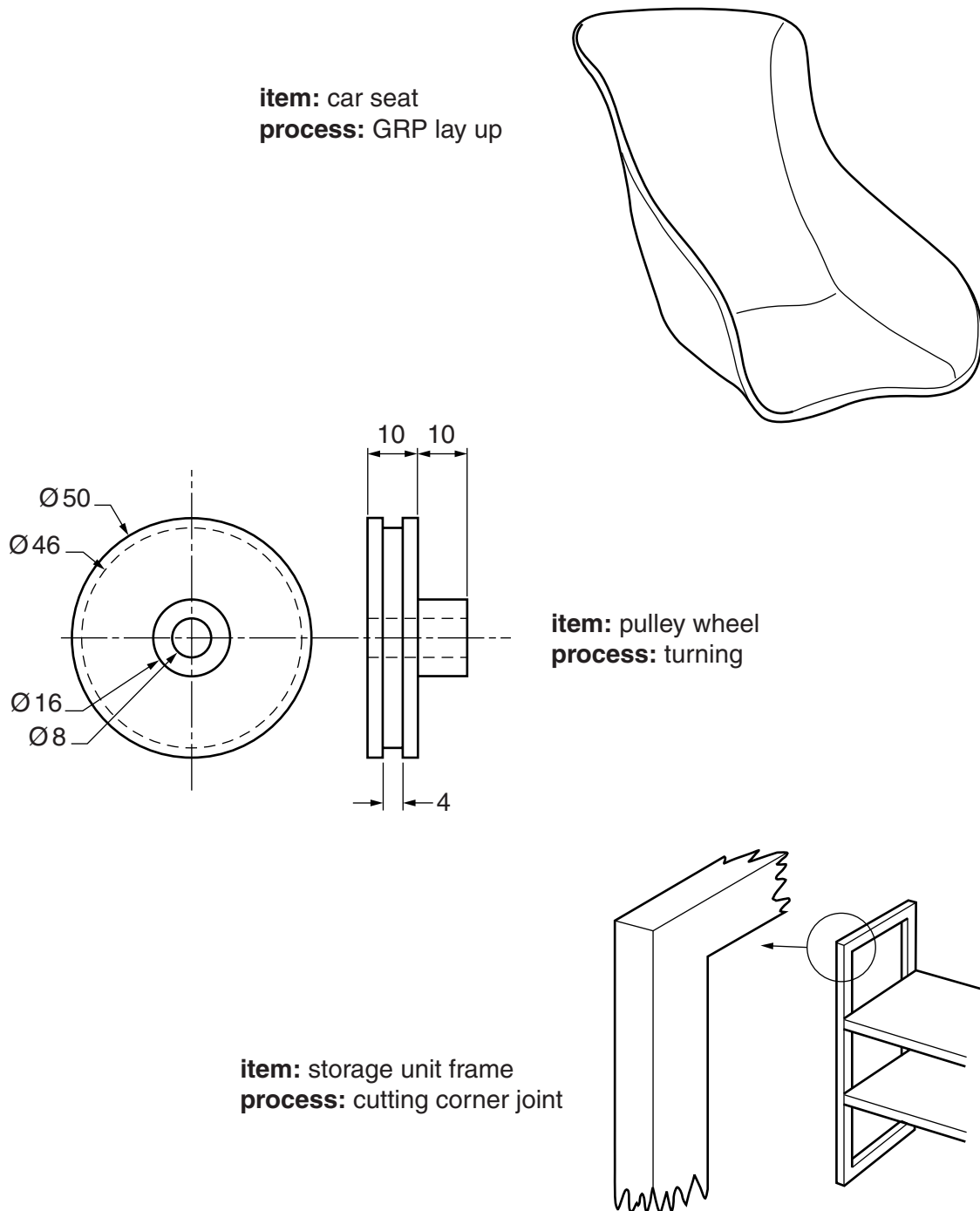

Fig. 2

Choose **two** of the items shown in Fig. 2 and for each:

- (a) use notes and sketches to describe the manufacture of the item using the process given; [7 × 2]
- (b) explain why the process is particularly suitable for the production of the item. [3 × 2]

Part B – Practical Technology

- 4 Fig. 3 shows a clamping device, used to hold work on a drilling machine.

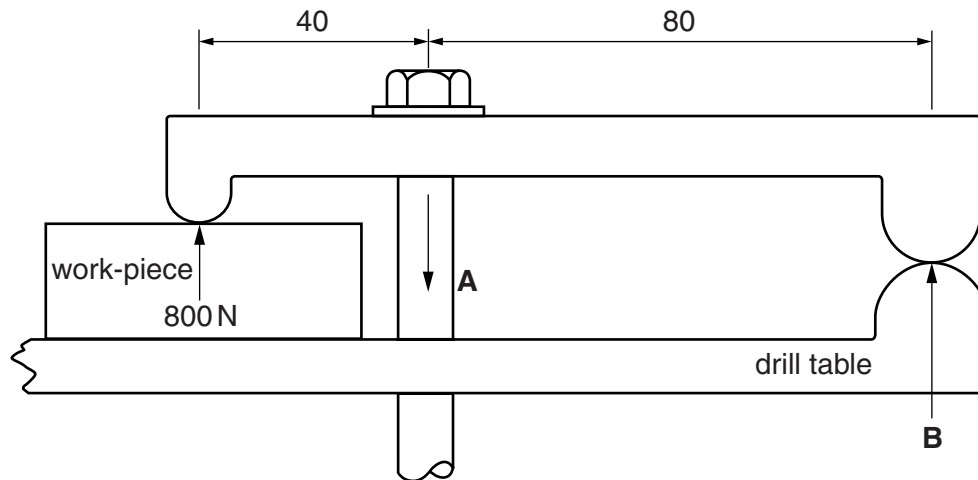

Fig. 3

- (a) (i) Calculate the force **B** at the drill table. [3]
- (ii) Calculate the force **A** in the bolt. [3]
- (iii) Suggest a modification to the device so that the force on the work-piece is increased. [2]
- (b) The drill table is made from a cast aluminium alloy.
Use notes and sketches to explain the difference between the sand casting and the die-casting processes and comment on their suitability for one off or volume production. [12]
- 5 (a) (i) Use notes and sketches to show a mechanism that will transfer linear motion to rotary motion. [2]
- (ii) Use notes and sketches to show a mechanism that will transfer rotary motion to rotary motion through 90° . [2]
- (b) (i) Define **two** of the properties listed below.
- Hardness
 - Stiffness
 - Tensile strength
- [2]
- (ii) Use notes and sketches to describe tests for **two** of the properties in (b) (i). [8]
- (iii) Engineers carry out tests to ensure the suitability and safety of products.
Explain the following with reference to the testing of materials and structures.
- Strain gauge
 - Photoelasticity
- [6]

5

- 6 (a) Describe what is meant by AC and DC current. Give an example of each. [4]
- (b) Fig. 4 shows a simple circuit for a lamp.

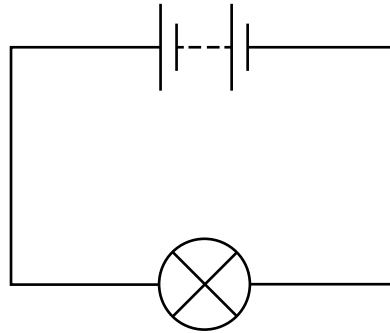
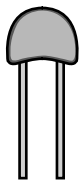
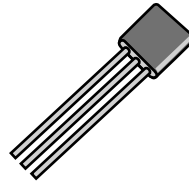
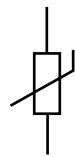

Fig. 4

- (i) Calculate the current if the battery is 36 volts and the resistance is 3Ω . [2]
- (ii) Calculate the power dissipated by the lamp. [2]
- (c) Fig. 5 shows three electronic components and their symbol used in circuit diagrams. Identify each component and describe its function. Give an application of use for each of the components.



Component 1



Component 2

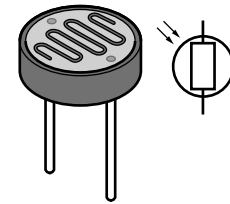
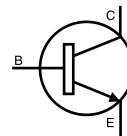

Component 3

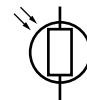

Fig. 5

[4 × 3]

Part C – Graphic Products

7 Explain the importance of each the following in the process of designing and making products. Use an example of each to support your answer.

- Exploded and cut-away drawings
- Full size prototype
- Computer simulation

[20]

8 Fig. 6 shows orthographic views of a Toolmaker's Clamp.

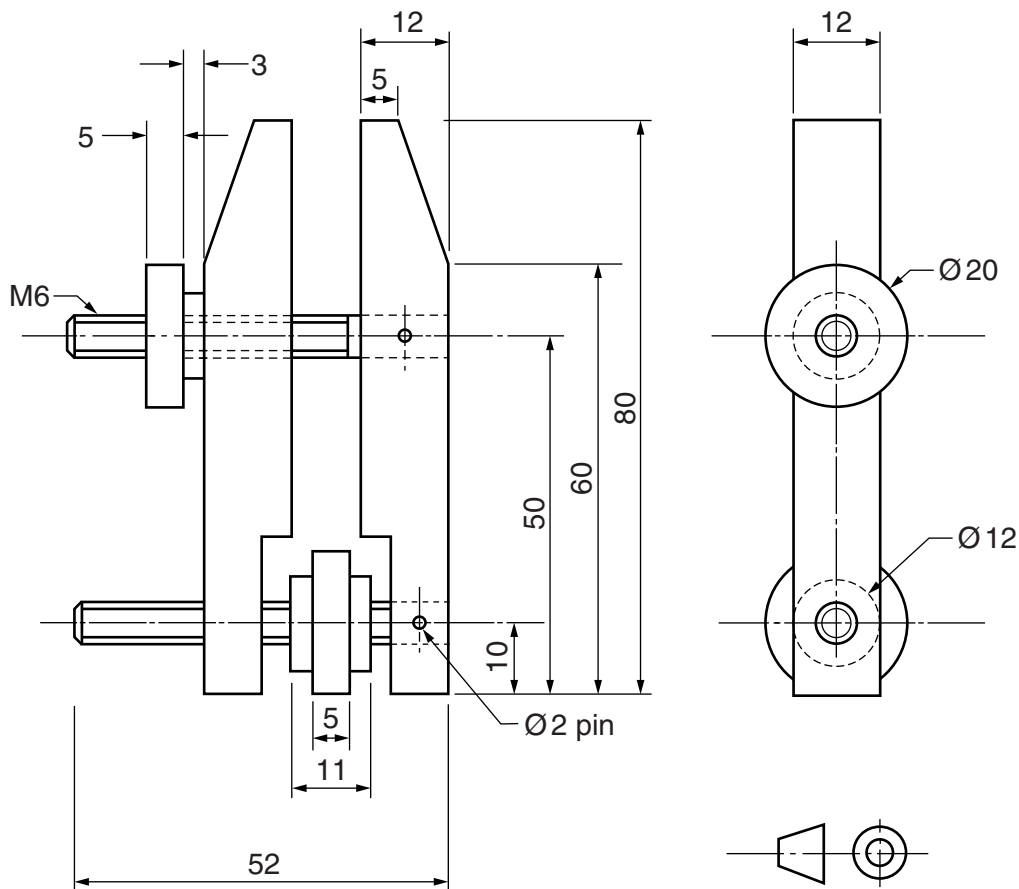

Fig. 6

Draw, to a scale of 2:1, an isometric drawing of the toolmakers clamp.

[20]

9 Fig. 7 shows the plan of a kitchen.

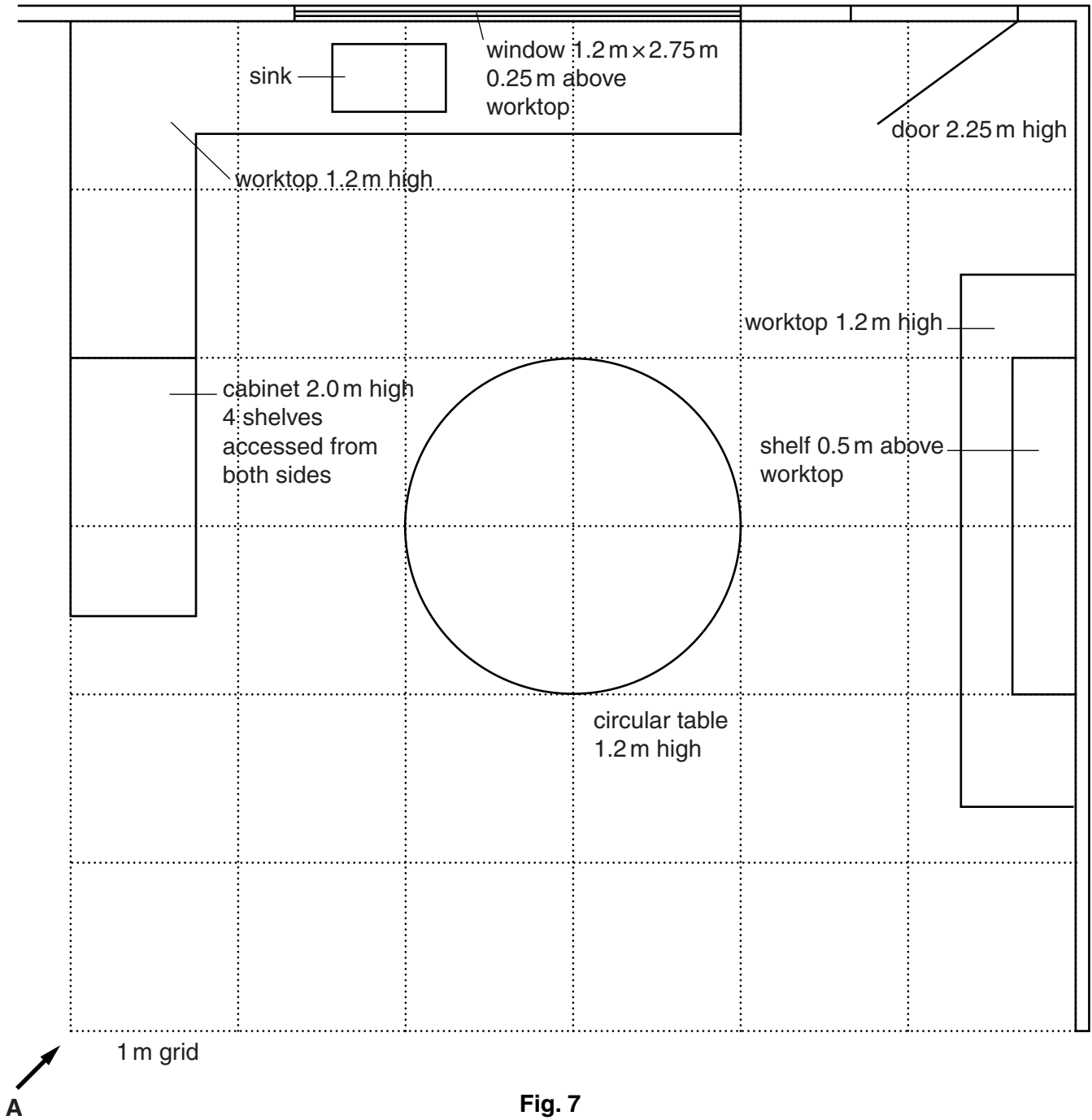

Fig. 7

Draw, to an approximate scale, a planometric drawing of the kitchen viewed from arrow **A**. [20]

Section B

Answer **one** question on the A3 paper provided.

You should approach the design question of your choice in the following manner:

Analysis

Produce an analysis of the given situation/problem, which may be in written or graphical form. [5]

Specification

From the analysis produce a detailed written specification of the design requirements. Include at least five specification points other than those given in the question. [5]

Exploration

Use bold sketches and brief notes to show your exploration of ideas for a design solution, with reasons for selection. [25]

Development

Show, using bold sketches and notes, the development, reasoning and composition of ideas into a single design proposal. Give details of materials, constructional and other relevant technical details. [25]

Proposed solution

Produce drawings of an appropriate kind to show the complete solution. [15]

Evaluation

Give a written evaluation of the final design solution. [5]

[Total: 80]

10 People often wish to relax after a hard day's work.

Design a product that would enable a person to sit or recline in a comfortable and relaxing position.

The product must be:

- adjustable to provide a range of sitting and reclining positions;
- able to be used indoors and outdoors.

Anthropometric details are given in Fig. 8.

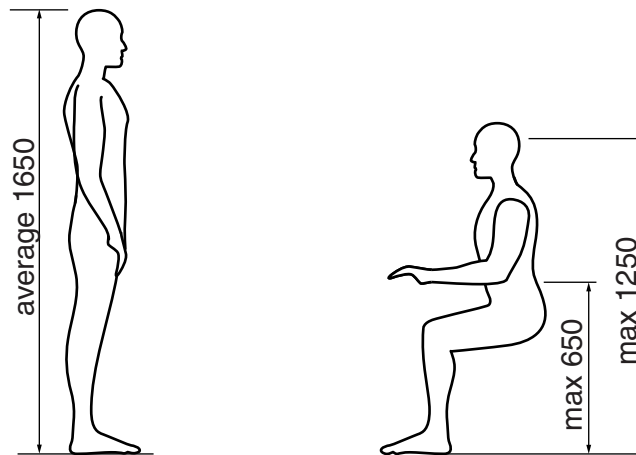

Fig. 8

11 Cyclists often wish to use GPS (Global Positioning System) applications on their mobile phones when cycling.

Design a product that would hold a mobile phone on the handlebars of a cycle.

The product must:

- be easily attached to the handlebars of a cycle;
- include a locking system to prevent theft of the mobile phone.

Details of the handlebars and the approximate sizes of a mobile phone are given in Fig. 9.

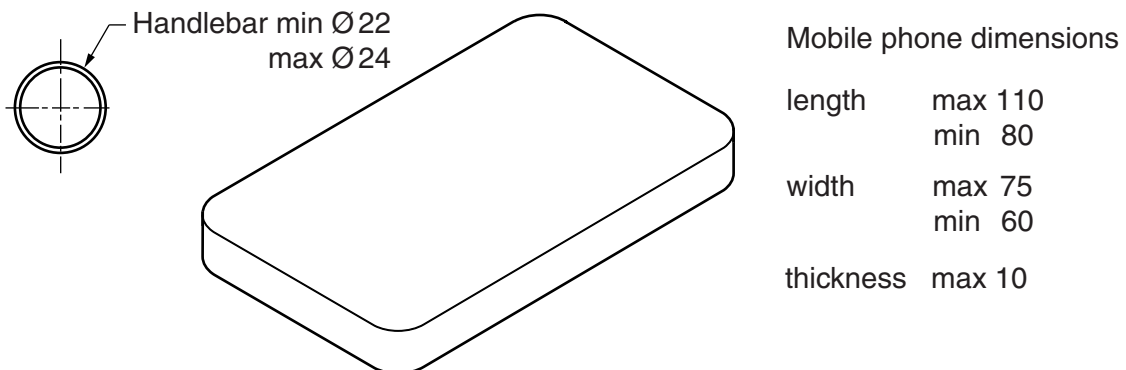

Fig. 9

12 The Green Valley Sports Hotel provides packed meals for guests who do not wish to eat lunch on the premises.

The packed meal would include sandwiches, a portion of fruit and a carton of drink.

Design a product that would securely hold all of the items in a packed lunch.

The product must:

- be easily assembled from one sheet of card;
- reflect the image of the Hotel.

Details of approximate sizes of the sandwiches and drinks carton are given in Fig. 10.

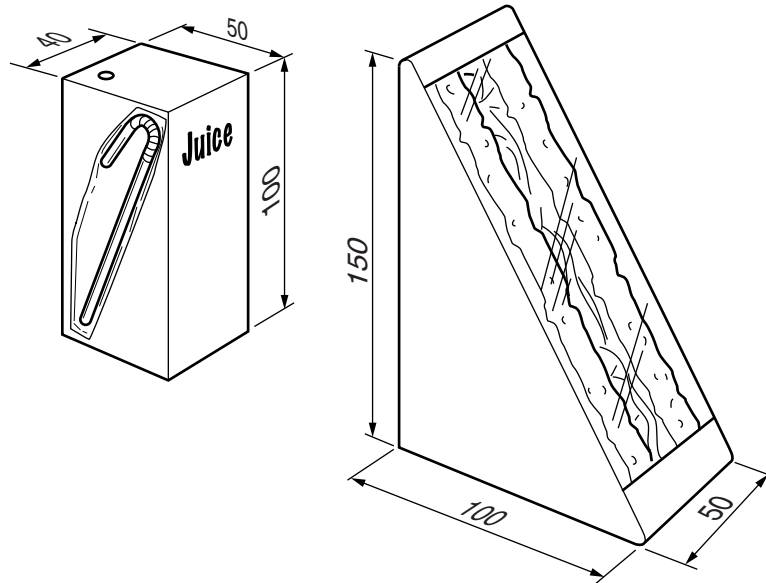

Fig. 10

BLANK PAGE

Permission to reproduce items where third-party owned material protected by copyright is included has been sought and cleared where possible. Every reasonable effort has been made by the publisher (UCLES) to trace copyright holders, but if any items requiring clearance have unwittingly been included, the publisher will be pleased to make amends at the earliest possible opportunity.

To avoid the issue of disclosure of answer-related information to candidates, all copyright acknowledgements are reproduced online in the Cambridge International Examinations Copyright Acknowledgements Booklet. This is produced for each series of examinations and is freely available to download at www.cie.org.uk after the live examination series.

Cambridge International Examinations is part of the Cambridge Assessment Group. Cambridge Assessment is the brand name of University of Cambridge Local Examinations Syndicate (UCLES), which is itself a department of the University of Cambridge.