

**DESIGN AND TECHNOLOGY****9705/12**

Paper 1

**October/November 2016****3 hours**

Additional Materials: Answer Booklet/A4 Paper  
 A3 Drawing Paper (2 sheets)  
 Extra sheets of A3 drawing paper for candidates who have used up both sides of their 2 sheets  
 A range of design drawing equipment

**READ THESE INSTRUCTIONS FIRST**

If you have been given an Answer Booklet, follow the instructions on the front cover of the Booklet.  
 Write your answers and working on the separate Answer Booklet/Paper provided.  
 Write your name, Centre number and candidate number on all the work you hand in.  
 Write in dark blue or black pen.  
 You may use an HB pencil, or coloured pencils/pens as appropriate, for any diagrams, graphs or rough working.  
 Do not use staples, paper clips, glue or correction fluid.  
**DO NOT WRITE IN ANY BARCODES.**

**Section A**

Answer **one** question on the Answer Booklet/A4 Paper provided.

**Section B**

Answer **one** question on the Answer Booklet/A4 Paper provided.

**Section C**

Answer **one** question on plain A3 paper.  
 Use **both** sides of the paper.  
 You may request additional sheets of A3 paper, but only if you have used up both sides of each of the 2 sheets provided.

You are advised to spend **30 minutes** on each of Sections A and B and **2 hours** on Section C.

At the end of the examination, fasten all your work securely together.  
 The number of marks is given in brackets [ ] at the end of each question or part question.  
 All dimensions are in millimetres.

This document consists of **11** printed pages and **1** blank page.

## Section A

Answer **one** question from this section on the Answer Booklet/A4 paper provided.

- 1 Fig. 1 gives details about a magazine rack which is to be made in a school workshop.

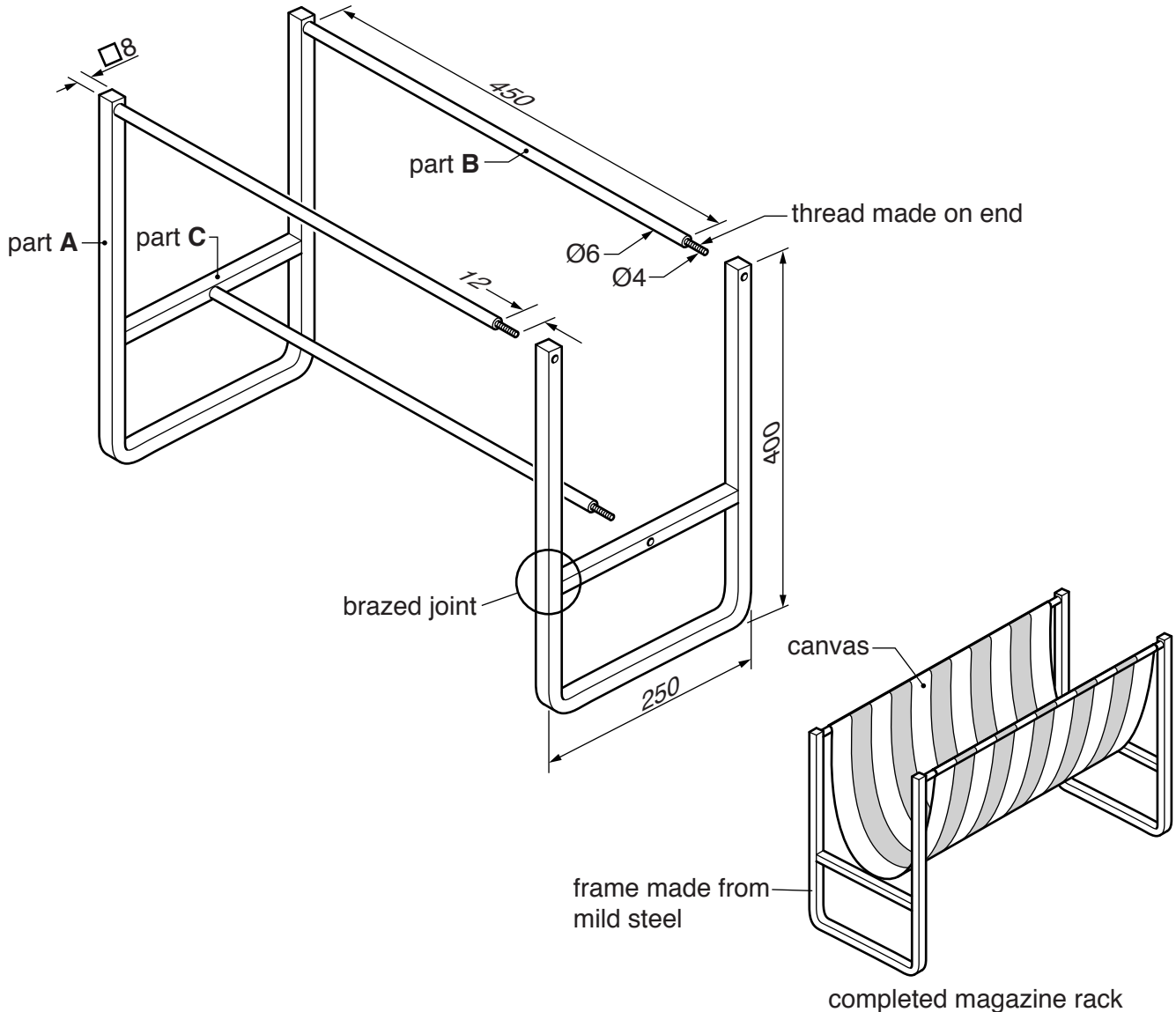

**Fig. 1**

- (a) Sketch a pictorial (3D) view of a nut that could be used to join part **A** to part **B**. [2]
- (b) Use notes and sketches to describe:
- (i) how part **A** could be bent; [6]
  - (ii) how the thread could be made on the end of part **B**; [6]
  - (iii) how parts **A** and **C** could be brazed together. [6]

You must give details about the tools, equipment and processes involved and the safety precautions that have to be undertaken at each stage.

- 2 Fig. 2 gives details about a hotel reception desk. The desk is made out of six pieces. A 1:10 scale model of the desk, made from card, is to be produced in a school workshop.

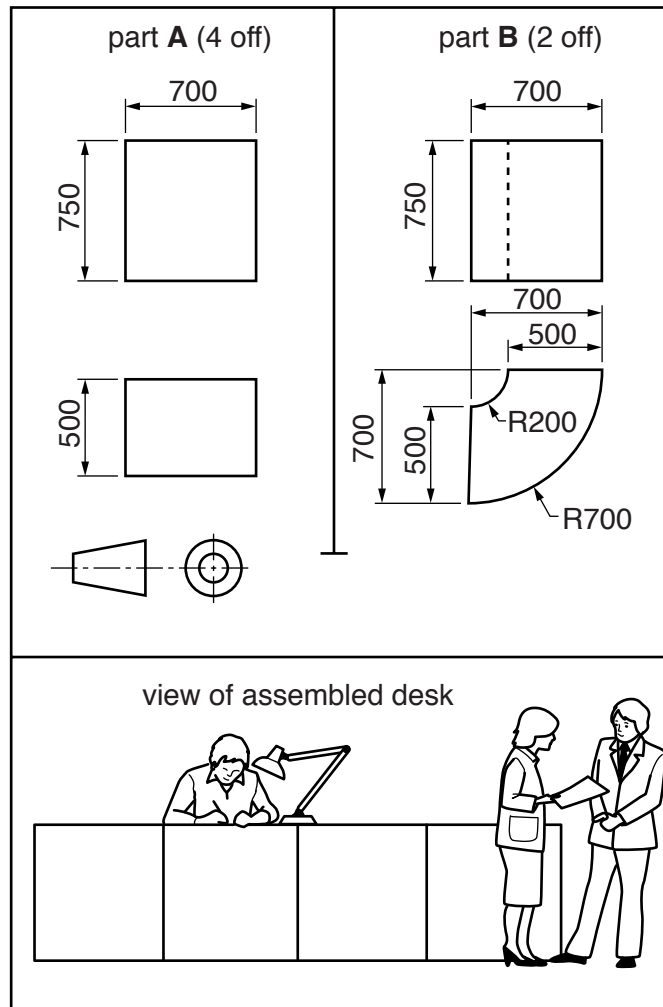

Fig. 2

- (a) State:
- (i) the height of the scale model of the desk; [1]
  - (ii) the length of the scale model of the desk. [1]
- (b) Sketch a pictorial (3D) view of the assembled desk. [6]
- (c) Use notes and sketches to describe:
- (i) how the one piece development (net) required to make part **A** could be marked out, cut out and assembled; [6]
  - (ii) how the one piece development (net) required to make part **B** could be marked out, cut out and assembled. [6]

You must give details about the tools, equipment and processes involved and the safety precautions that have to be undertaken at each stage.

4

- 3 Fig. 3 gives details about a toy boat, made from softwood, which is to be produced in a school workshop. The toy boat is made out of five parts which a child can take apart and put back together.

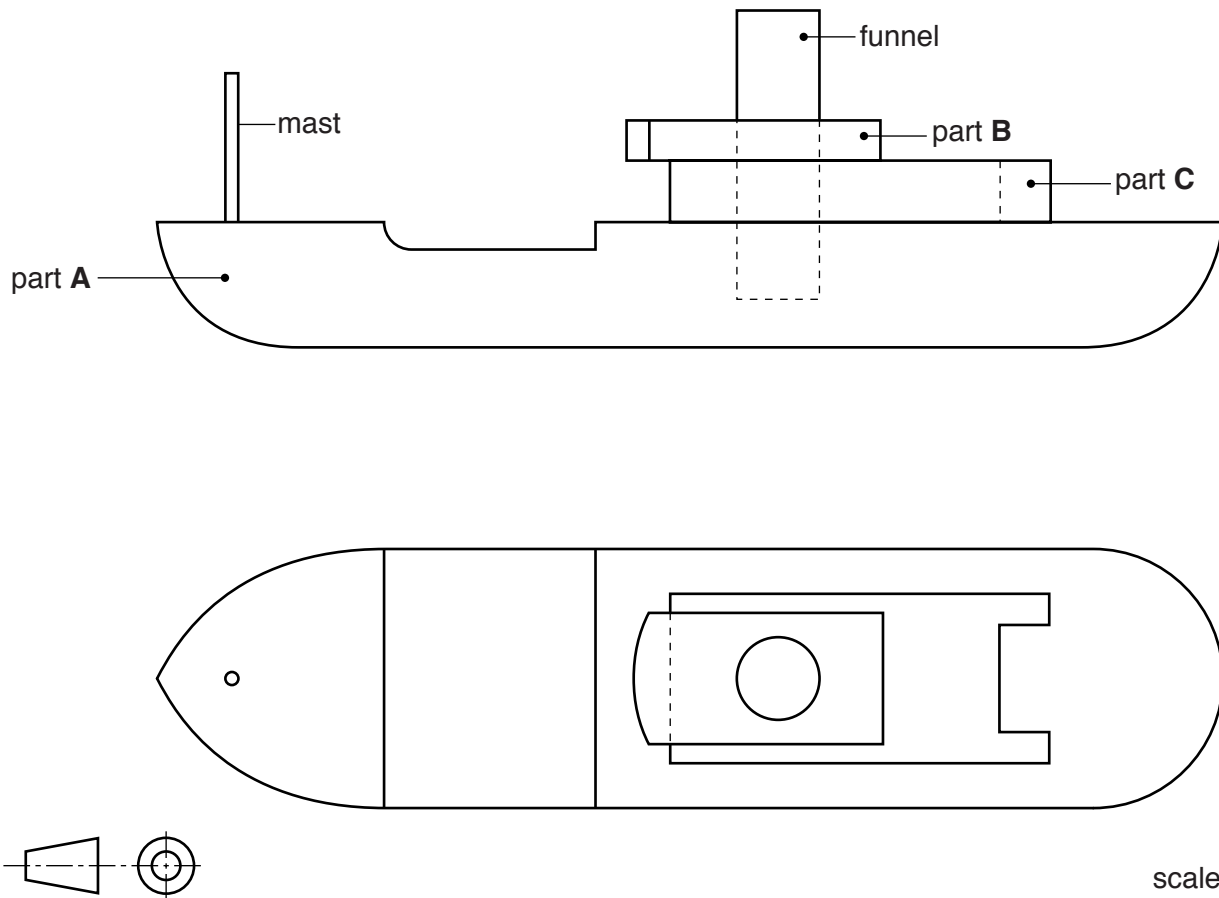

**Fig. 3**

- (a) State **two** safety issues that could be included in the specification for a wooden toy to be used by very young children. [2]
- (b) Use notes and sketches to describe:
- (i) how part **A** could be made; [6]
  - (ii) how parts **B** and **C** could be made; [6]
  - (iii) changes that could be made to the design to make the toy safer for young children to use. [6]

You must give details about the tools, equipment and processes involved and the safety precautions that have to be undertaken at each stage.

## Section B

Answer **one** question from this section on the Answer Booklet/A4 paper provided.

- 4 Fig. 4 shows a sand casting mould that has been prepared ready for the molten metal to be poured in.

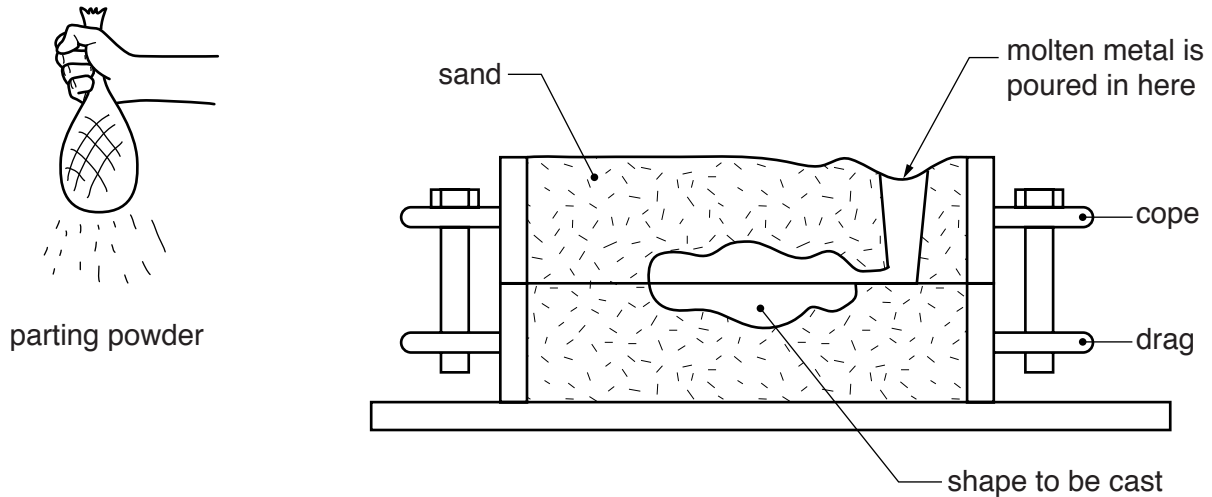

Fig. 4

- (a) Explain why parting powder has been used in the preparation of the mould. [2]
- (b) Identify and describe **two** problems with the mould. [4]
- (c) Using notes and sketches, explain how the mould would need to be changed to overcome the two problems you have identified in (b). [6]
- (d) Discuss how and why the quality of products produced by sand casting differs from those produced by die casting.

Your answer should:

- (i) analyse the given situation and identify **three** relevant issues raised by the question; [3]
- (ii) explain why you consider these issues to be relevant; [3]
- (iii) contain specific examples/evidence to support your conclusions. [2]

5 Fig. 5 shows a ceramic vase and a design for a box to package the vase.

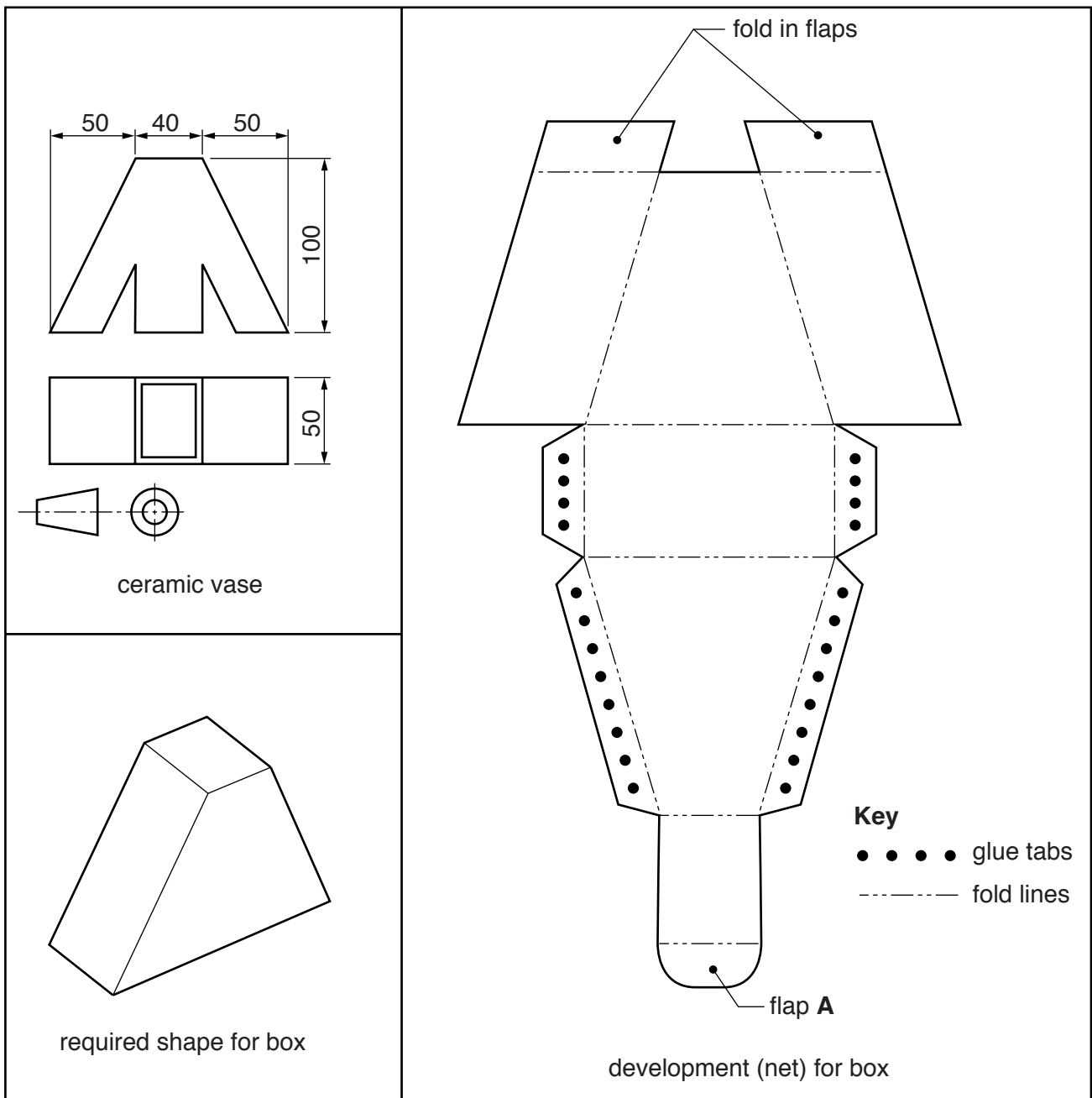

Fig. 5

- (a) Explain why the corners of flap **A** have been rounded. [2]
- (b) Identify and describe **two** problems with the design of the development (net). [4]
- (c) Using notes and sketches, explain how the design for the development (net) would need to be changed to overcome the two problems you have identified in (b). [6]

- (d) Discuss how and why manufacturers are addressing the negative effect that packaging can have on the environment.

Your answer should:

- (i) analyse the given situation and identify **three** relevant issues raised by the question; [3]
- (ii) explain why you consider these issues to be relevant; [3]
- (iii) contain specific examples/evidence to support your conclusions. [2]

- 6 Fig. 6 gives details about a wall mounted cabinet with a fold down front. Metal stays are used to hold the front of the cabinet in a horizontal position when it is open.

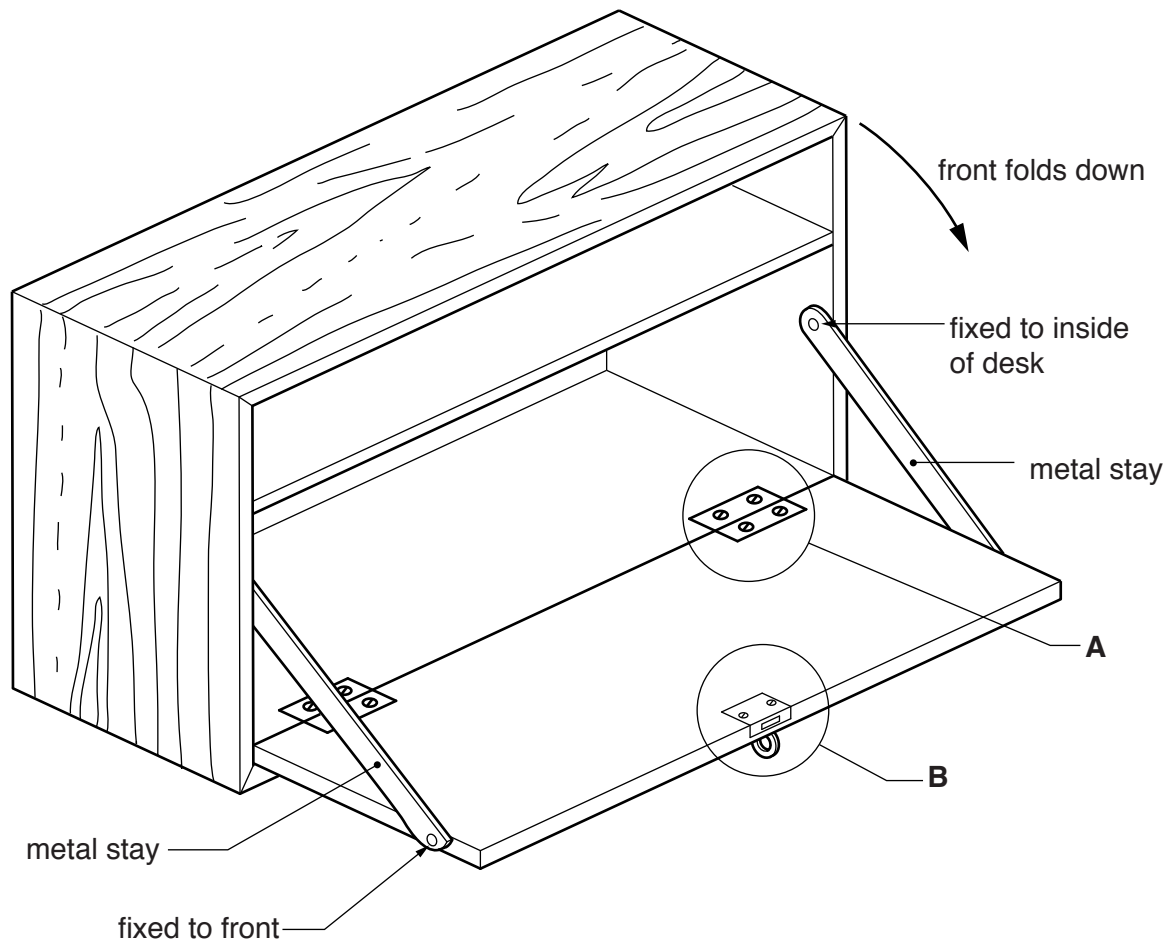

Fig. 6

- (a) Name the fitting:
- (i) shown at **A**; [1]
  - (ii) shown at **B**. [1]
- (b) Identify and describe **two** problems with the design of the metal stays. [4]
- (c) Using notes and sketches, explain how the design of the metal stays would need to be changed to overcome the two problems you have identified in (b). [6]
- (d) Discuss why manufacturers are making increased use of knock-down (temporary) fittings in the production of furniture and the effect this has on their customers.

Your answer should:

- (i) analyse the given situation and identify **three** relevant issues raised by the question; [3]
- (ii) explain why you consider these issues to be relevant; [3]
- (iii) contain specific examples/evidence to support your conclusions. [2]



## Section C

Answer **one** question from this section on the plain A3 paper provided

You are provided with two sheets of plain A3 paper. You should use **both** sides of the paper. **Each** of the four parts (a)–(d) of the question you choose to answer should take up one side of paper.

When you are asked to **develop** a design you must show, using notes and sketches, the development and evaluation of a **range** of ideas into a single solution. The design proposal should be annotated to give details about materials, joining methods and important sizes.

7 Fig. 7 shows an incomplete idea for a folding picnic table.

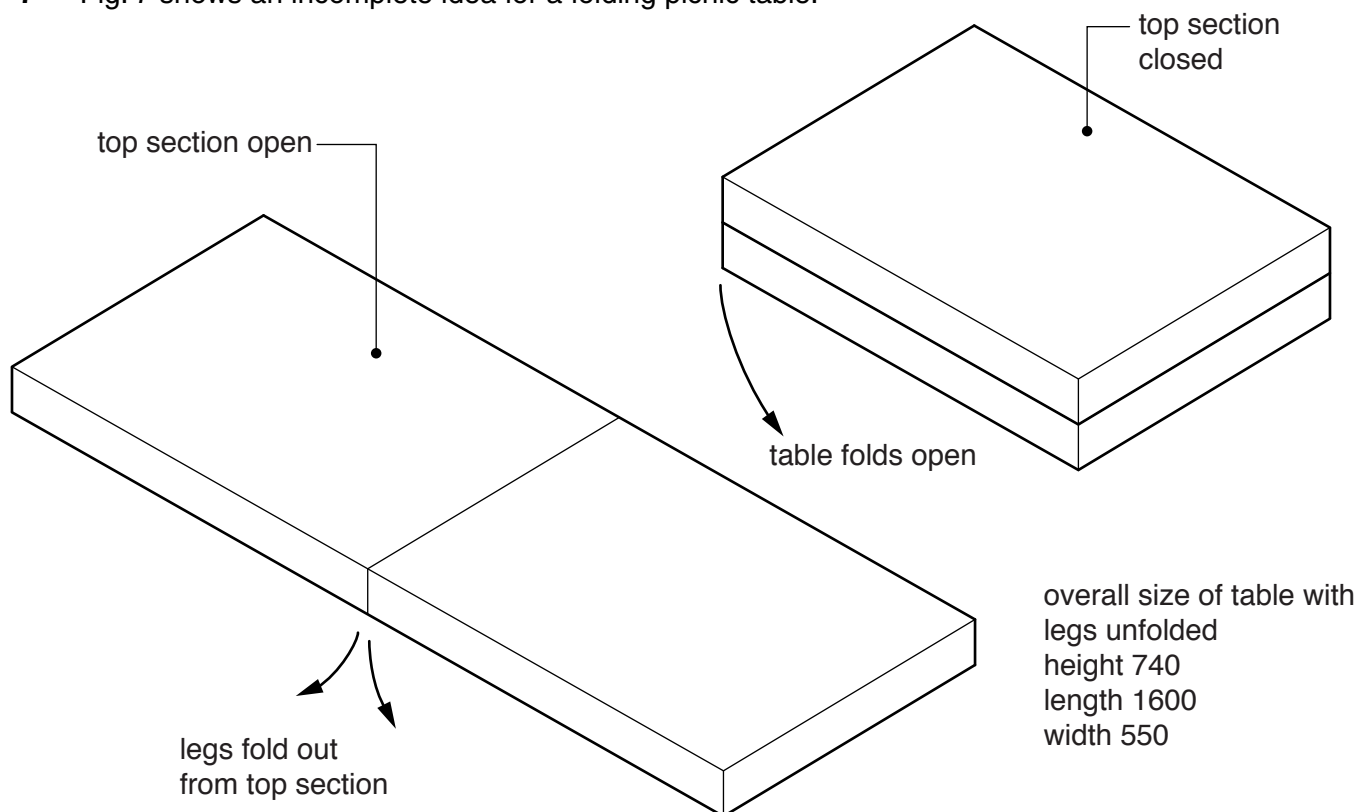

Fig. 7

- (a) Using notes and sketches, **develop** a design for the top section of the picnic table. The design must include a method of keeping the top section securely closed when it is folded in half with the legs inside. [20]
- (b) Using notes and sketches, **develop** a design for the folding legs. The design must include methods that allow the legs to be folded in and out of the top section and fix them securely when in the open position. [20]
- (c) Using notes and sketches, **develop** a design which enables the picnic table to be carried but keeps both hands free. The design must be easily removed from the table when it is not required. [20]
- (d) Produce a pictorial rendered drawing of the complete picnic table which shows all of the features that you have designed in (a)–(c). The picnic table should be shown with the legs unfolded. [20]

- 8 Fig. 8 shows an incomplete idea for a counter top display stand which will be used to promote a DVD science fiction film titled '**Rocket to the Moon and beyond**'. Most of the design will be made from corrugated cardboard.

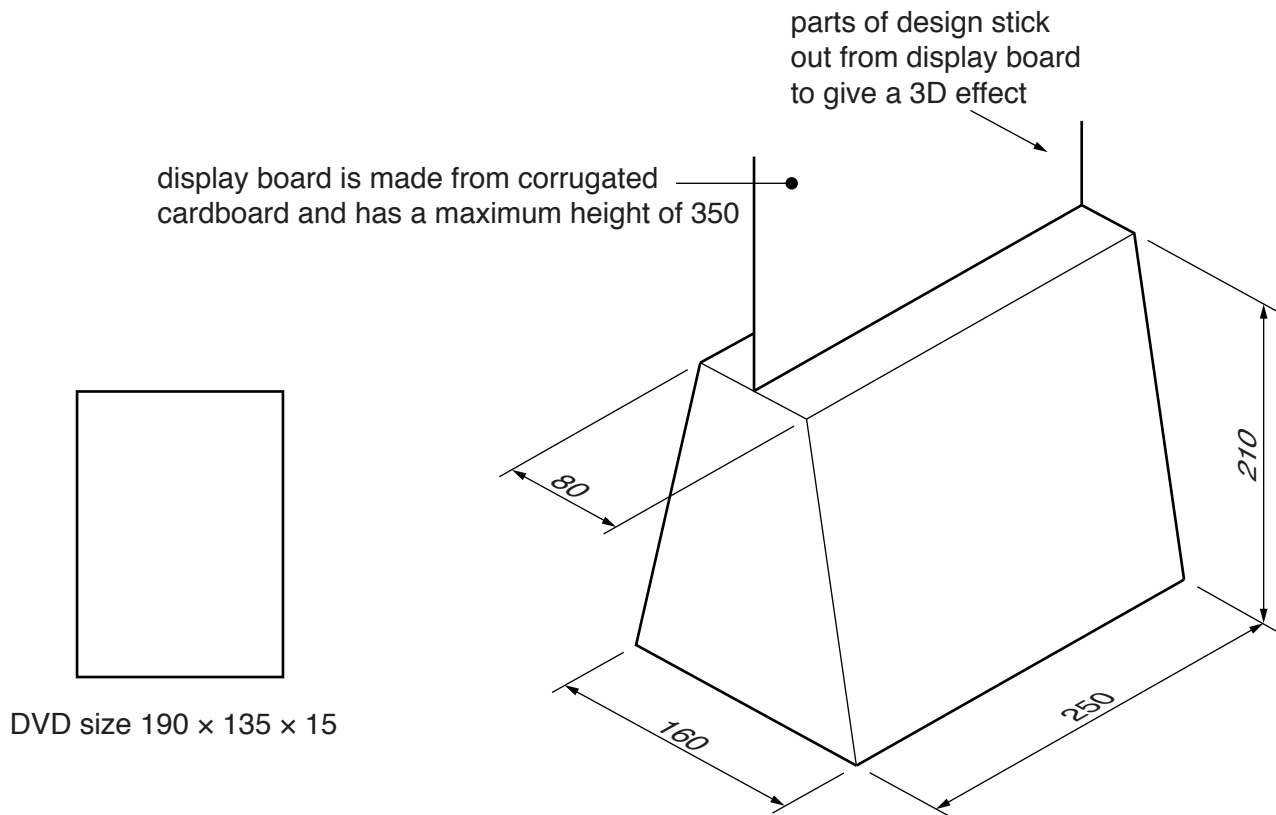

Fig. 8

- (a) Using notes and sketches, **develop** a design for the display board. The shape of the display board must reflect the title of the film and include some 3D (three dimensional) features that stick out from the display board. [20]
- (b) Using notes and sketches, **develop** a design for a DVD holder made from corrugated cardboard. The holder must be capable of being attached to the display stand without the use of glue or other additional materials and allow most of the front of the DVD to be visible. [20]
- (c) Using notes and sketches, **develop** a design for the lettering to go on the display stand. The title of the film is '**Rocket to the Moon and beyond**' and the lettering should be in a style that reflects the title. [20]
- (d) Produce a pictorial rendered drawing of the complete counter top display stand which shows all of the features that you have designed in (a)–(c). Do not include the DVD in your drawing. [20]

- 9 Fig. 9 shows an incomplete idea for a garden swing seat to hold two people.

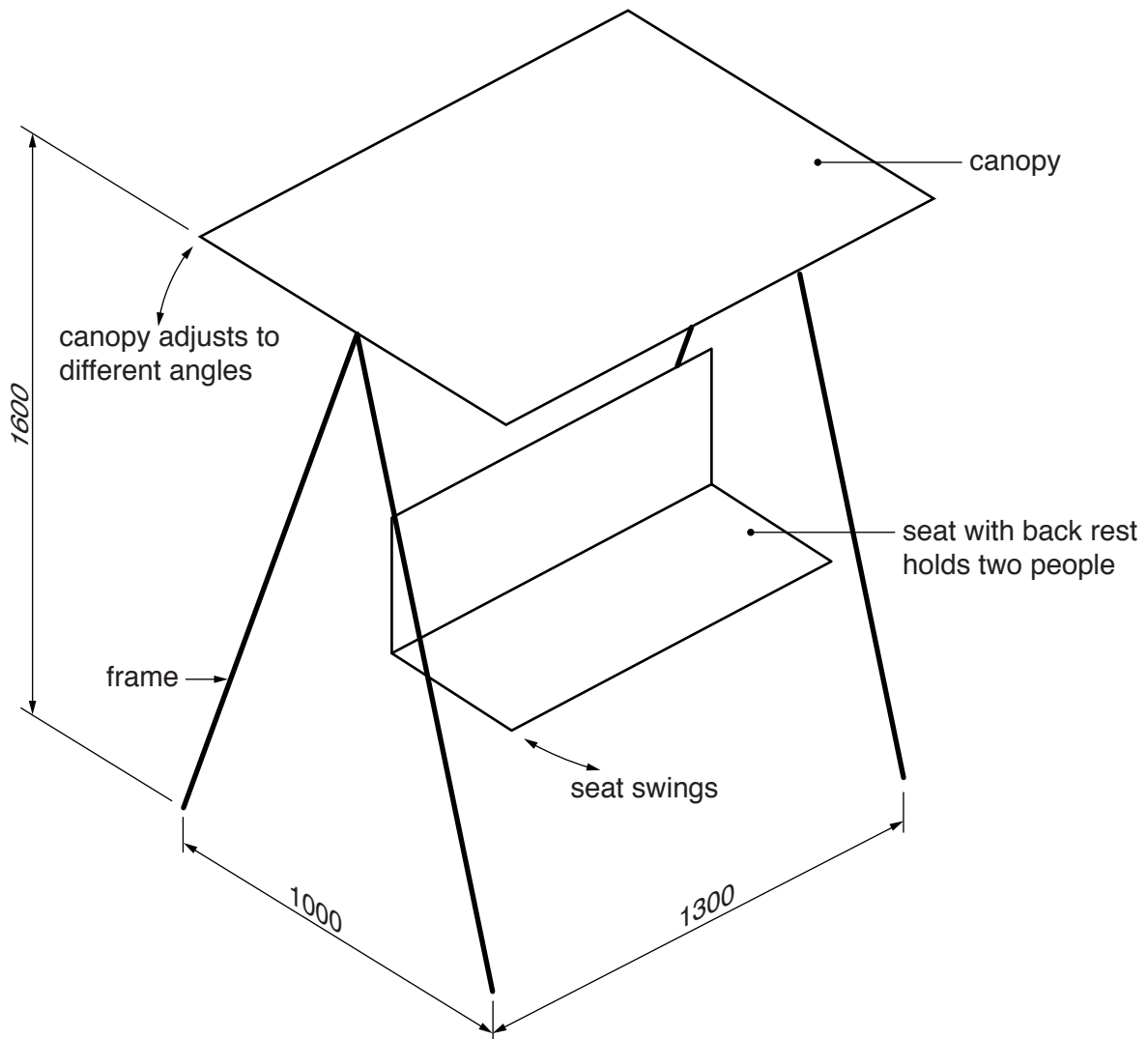

Fig. 9

- (a) Using notes and sketches, **develop** a design for a seat to hold two people. The design must include a back rest. [20]
- (b) Using notes and sketches, **develop** a design for a stable frame from which the seat can be hung. The design must include a method of hanging the seat from the frame which allows the seat to swing. [20]
- (c) Using notes and sketches, **develop** a design for a canopy to go on the top of the frame to protect people from the weather. It must be possible to adjust and fix the canopy at different angles. [20]
- (d) Produce a pictorial rendered drawing of the complete garden swing seat which shows all of the features that you have designed in (a)–(c). [20]

**BLANK PAGE**

---

Permission to reproduce items where third-party owned material protected by copyright is included has been sought and cleared where possible. Every reasonable effort has been made by the publisher (UCLES) to trace copyright holders, but if any items requiring clearance have unwittingly been included, the publisher will be pleased to make amends at the earliest possible opportunity.

To avoid the issue of disclosure of answer-related information to candidates, all copyright acknowledgements are reproduced online in the Cambridge International Examinations Copyright Acknowledgements Booklet. This is produced for each series of examinations and is freely available to download at [www.cie.org.uk](http://www.cie.org.uk) after the live examination series.

Cambridge International Examinations is part of the Cambridge Assessment Group. Cambridge Assessment is the brand name of University of Cambridge Local Examinations Syndicate (UCLES), which is itself a department of the University of Cambridge.