

DESIGN AND TECHNOLOGY

9705/11

Paper 1

October/November 2017

3 hours

Additional Materials: Answer Booklet/A4 Paper
 A3 Drawing Paper (2 sheets)
 Extra sheets of A3 drawing paper for candidates who have used up both sides of their 2 sheets
 A range of design drawing equipment

**READ THESE INSTRUCTIONS FIRST**

If you have been given an Answer Booklet, follow the instructions on the front cover of the Booklet.
 Write your name, Centre number and candidate number on all the work you hand in.

Write in dark blue or black pen.

You may use an HB pencil, or coloured pencils/pens as appropriate, for any diagrams, graphs or rough working.

Do not use staples, paper clips, glue or correction fluid.

DO **NOT** WRITE IN ANY BARCODES.

Section A

Answer **one** question on the Answer Booklet/A4 Paper provided.

Section B

Answer **one** question on the Answer Booklet/A4 Paper provided.

Section C

Answer **one** question on plain A3 paper.

Use **both** sides of the paper.

You may request additional sheets of A3 paper, but only if you have used up both sides of each of the 2 sheets provided.

You are advised to spend **30 minutes** on each of Sections A and B and **2 hours** on Section C.

At the end of the examination, fasten all your work securely together.

The number of marks is given in brackets [] at the end of each question or part question.

All dimensions are in millimetres.

This document consists of **10** printed pages and **2** blank pages.

Section A

Answer **one** question from this section on the Answer Booklet/A4 paper provided.

- 1 Fig. 1 gives details about a combined desk and seat unit which is to be made in a school workshop. Five parts, made from blockboard, will slot together to make the frame that supports the top (part **A**) and the seat (part **B**).

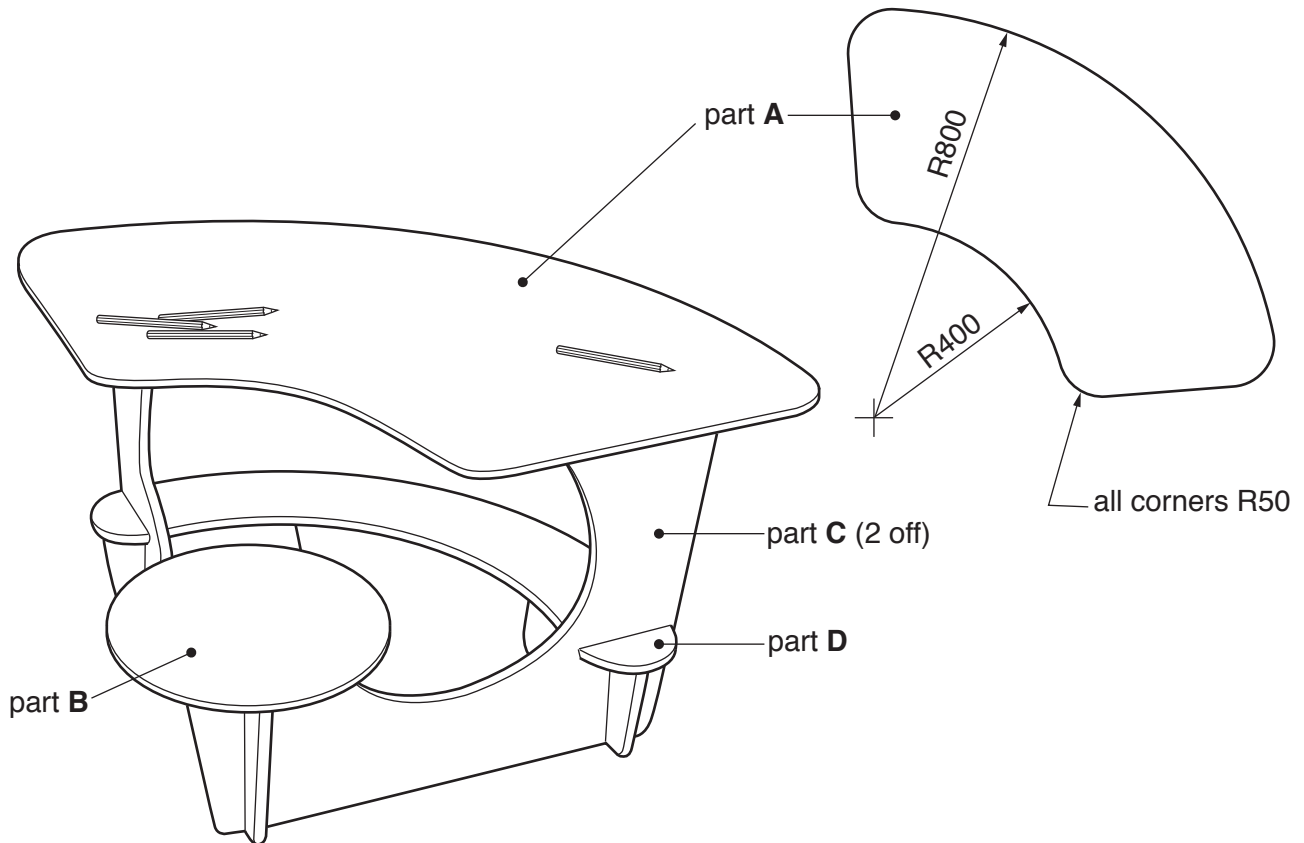

Fig. 1

- (a) Use a sketch and notes to show how blockboard is constructed. [2]
- (b) Use notes and sketches to describe:
- (i) how part **A** could be marked out, cut out and the edges of the blockboard smoothed; [6]
 - (ii) how part **A** could be joined to part **C** of the frame using knock-down (temporary) fittings. [6]
- (c) Sketch the shape, including the slots, that would need to be cut out to make:
- (i) part **C**; [3]
 - (ii) part **D**. [3]

You must give details about the tools, equipment and processes involved and the safety precautions that have to be undertaken at each stage.

3

- 2 Fig. 2 shows a table which will be made in a school workshop. The table will be made from three pieces of 5 mm thick corrugated cardboard which slot together.

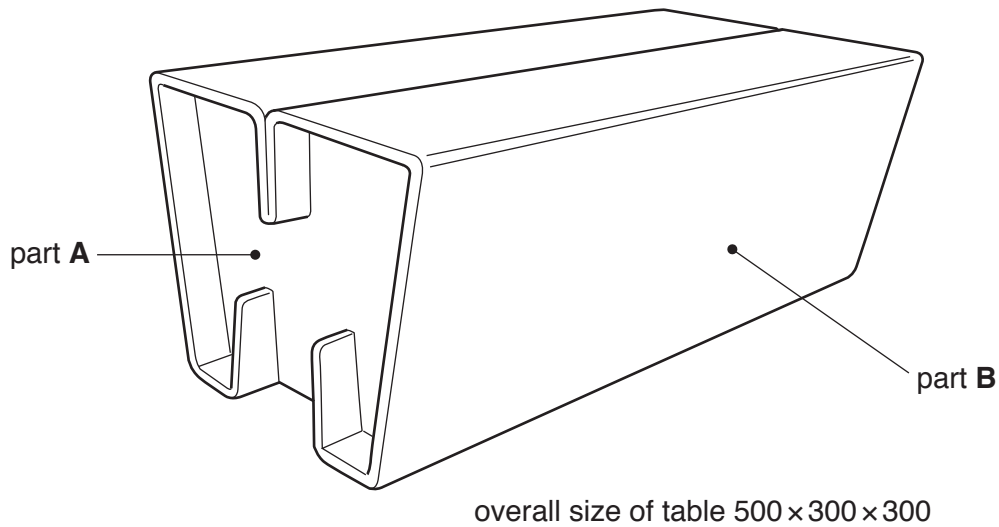
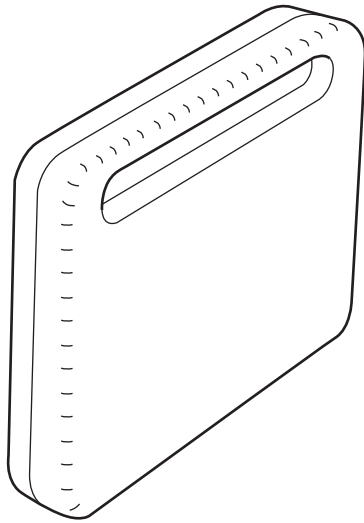

Fig. 2

- (a) Use a sketch and notes to explain why it can be difficult to fold corrugated cardboard. [2]
- (b) Sketch the shape, including any slots and folds, that would need to be cut out to make:
- (i) part A; [4]
- (ii) part B. [8]
- (c) Use notes and sketches to describe how CAM (Computer Aided Manufacture) could be used when making the table. [6]

You must give details about the tools, equipment and processes involved and the safety precautions that have to be undertaken at each stage.

- 3 Fig. 3 gives details about a case to carry drawing equipment which is to be made in a school workshop. The two halves of the case will be vacuum formed from plastic.

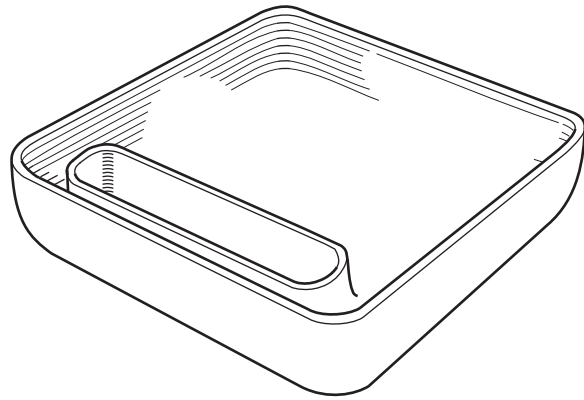

assembled case

view inside one half of the case
overall size 280 × 210 × 25**Fig. 3**

- (a) Name a suitable plastic for making the case and give **one** reason for your choice. [2]
- (b) Use notes and sketches to describe:
- (i) how the mould over which one half of the case would be vacuum formed could be made; [6]
 - (ii) how one half of the case could be vacuum formed; [6]
 - (iii) how the two halves of the case could be joined using hinges. [6]

You must give details about the tools, equipment and processes involved and the safety precautions that have to be undertaken at each stage.

Section B

Answer **one** question from this section on the Answer Booklet/A4 paper provided.

- 4 Fig. 4 shows a hand held circular saw being used.

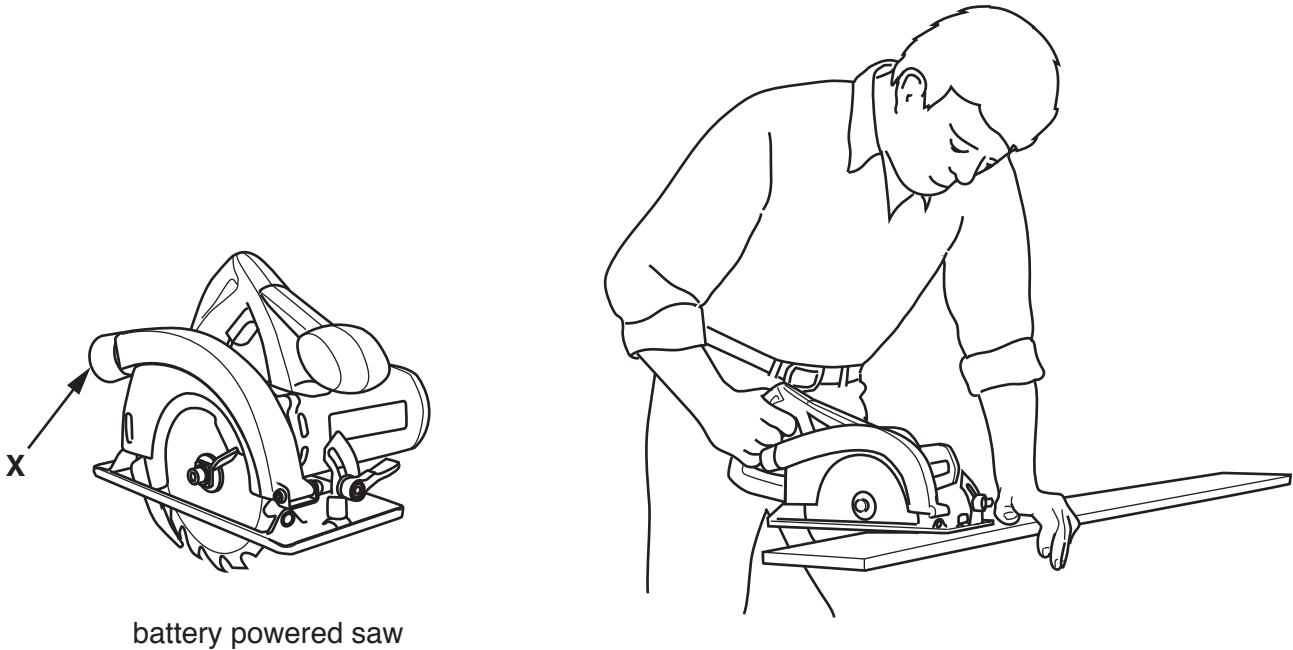

Fig. 4

- (a) Explain the function of the design feature shown at **X**. [2]
- (b) Identify and describe **two** problems that make the working conditions shown in Fig. 4 dangerous. [4]
- (c) Using notes and sketches, explain how the working conditions would need to be changed to overcome the **two** problems you have identified in **part (b)**. [6]
- (d) Discuss why the use of battery powered hand tools has increased in recent years.

Your answer should:

- (i) analyse the given situation and identify **three** relevant issues raised by the question; [3]
- (ii) explain why you consider these issues to be relevant; [3]
- (iii) contain specific examples/evidence to support your conclusions. [2]

5 Fig. 5 gives details about a point of sale display stand made from card.

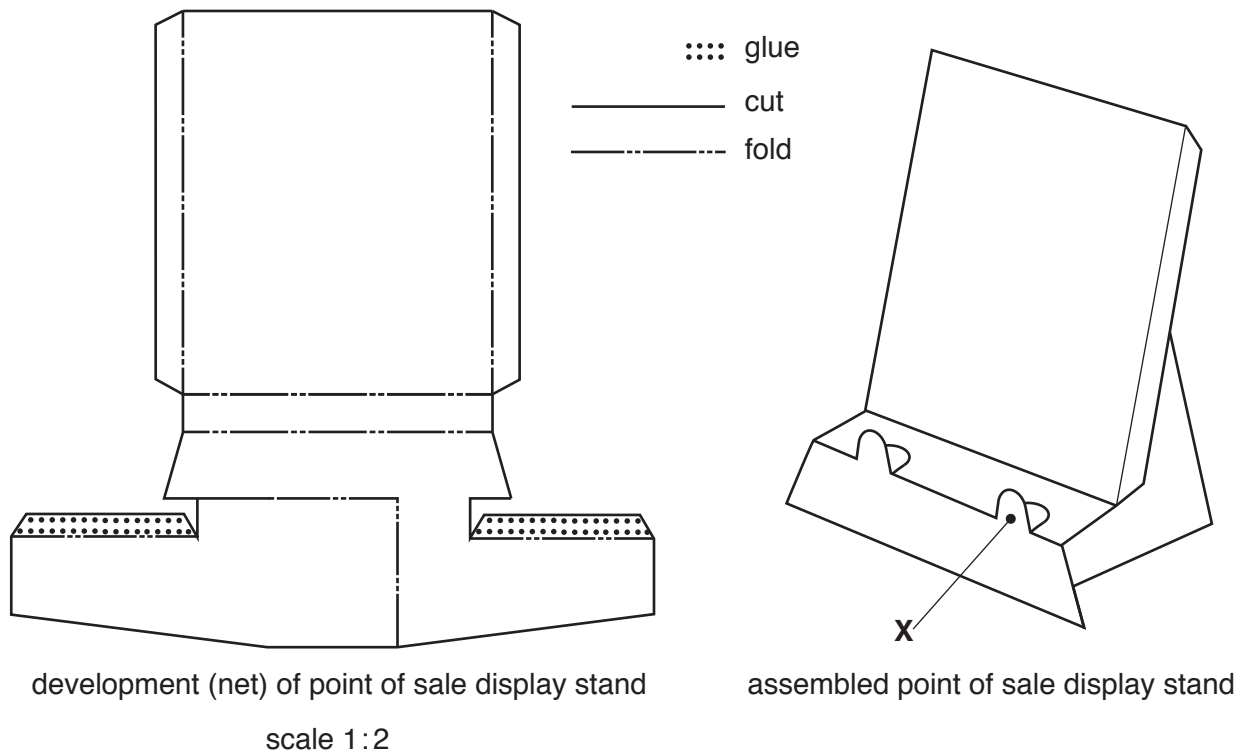

Fig. 5

- (a) Explain the function of the design feature shown at **X**. [2]
- (b) Identify and describe **two** problems with the development (net) required to make the point of sale display stand. [4]
- (c) Using notes and sketches, explain how the development (net) would need to be changed to overcome the **two** problems you have identified in **part (b)**. [6]
- (d) Discuss why many advertising products such as point of sale display stands have a limited life span.

Your answer should:

- (i) analyse the given situation and identify **three** relevant issues raised by the question; [3]
- (ii) explain why you consider these issues to be relevant; [3]
- (iii) contain specific examples/evidence to support your conclusions. [2]

- 6 Fig. 6 shows a chair which is made by laminating two sheets of 3 mm thick plywood together.

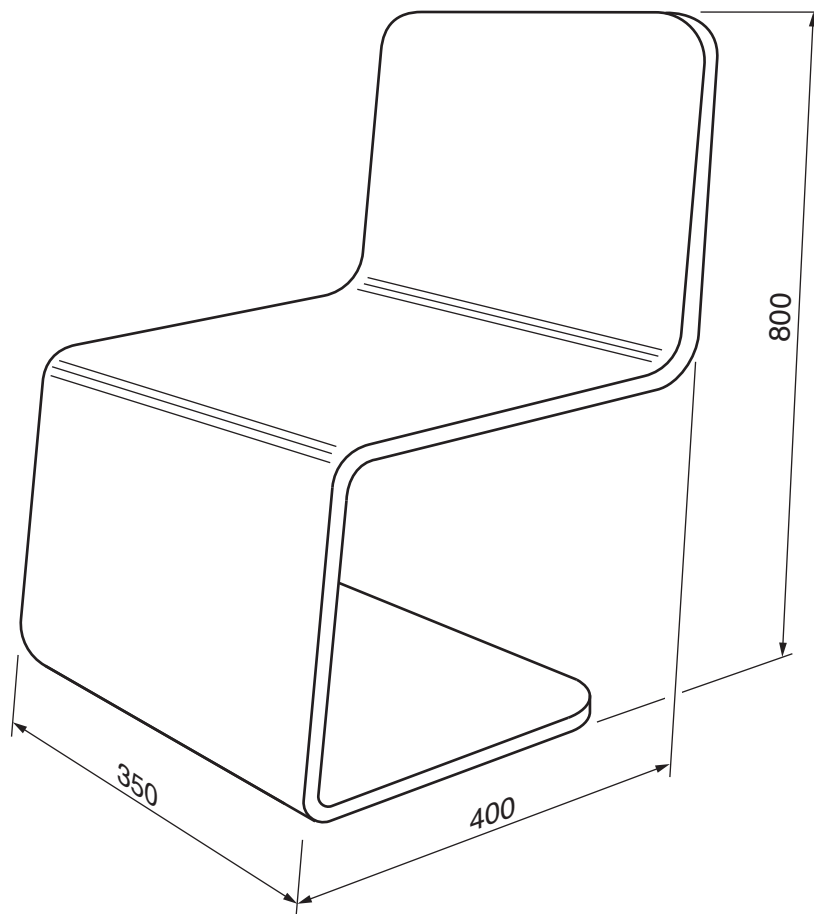

Fig. 6

- (a) Explain why thin plywood is often used in the lamination process. [2]
- (b) Identify and describe **two** structural problems with the design of the chair. [4]
- (c) Using notes and sketches, explain how the design would need to be changed to overcome the **two** problems you have identified in **part (b)**. [6]
- (d) Discuss the importance of model making in designing a new product.

Your answer should:

- (i) analyse the given situation and identify **three** relevant issues raised by the question; [3]
- (ii) explain why you consider these issues to be relevant; [3]
- (iii) contain specific examples/evidence to support your conclusions. [2]

Section C

Answer **one** question from this section on the plain A3 paper provided.

You are provided with two sheets of plain A3 paper. You should use **both** sides of the paper. **Each** of the four parts **(a)–(d)** of the question you choose to answer should take up one side of paper.

When you are asked to **develop** a design you must show, using notes and sketches, the development and evaluation of a **range** of ideas into a single design proposal. The design proposal should be annotated to give details about materials, joining methods and important sizes.

- 7 Fig. 7 shows an incomplete design for a high chair for children aged between six months and three years.

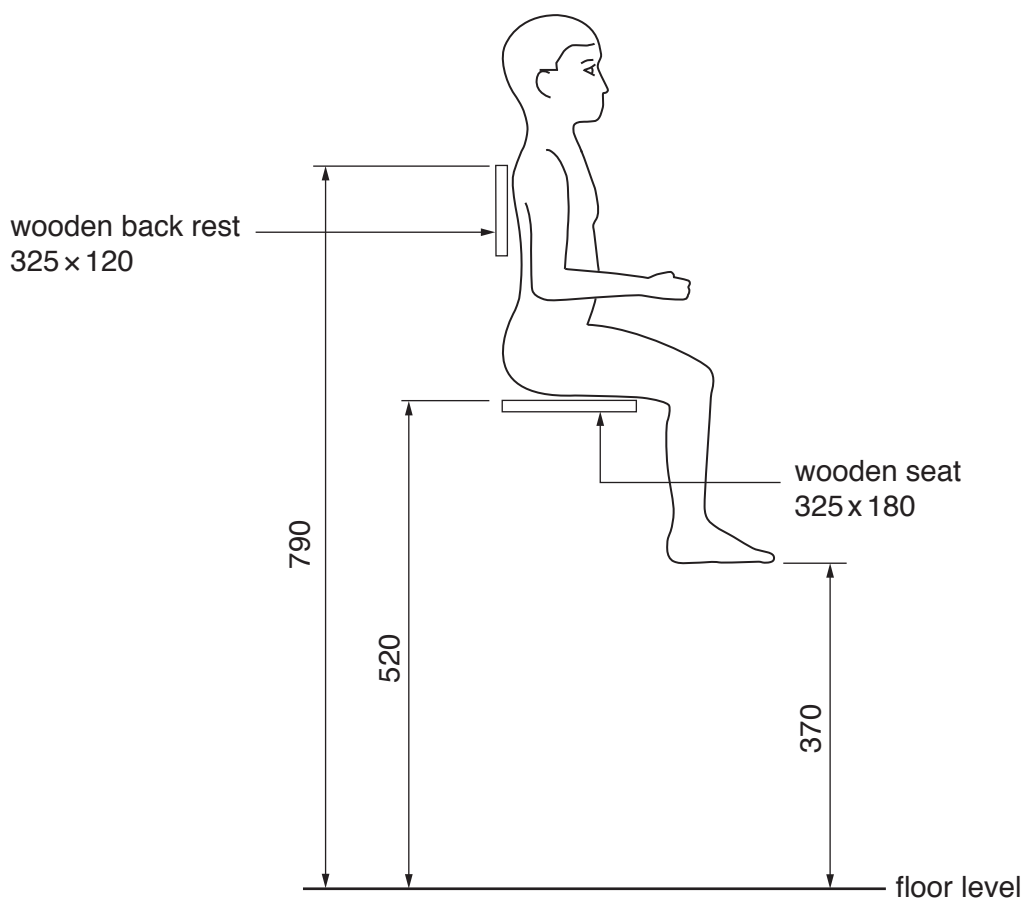

Fig. 7

- (a) Using notes and sketches, **develop** a design which supports the seat and back rest of the high chair at the heights shown in Fig. 7. The design must include a footrest. [20]
- (b) Using notes and sketches, **develop** a design which prevents a child from falling from the high chair. [20]
- (c) Using notes and sketches, **develop** a design for a tray which can be attached to, and easily removed from the high chair. The tray will be used when a child is feeding or playing whilst seated in the high chair. [20]
- (d) Produce a pictorial rendered drawing of the complete high chair which shows all of the features that you have designed in **parts (a)–(c)**. [20]

- 8 Fig. 8 shows a watch and an incomplete design for the packaging to hold the watch.

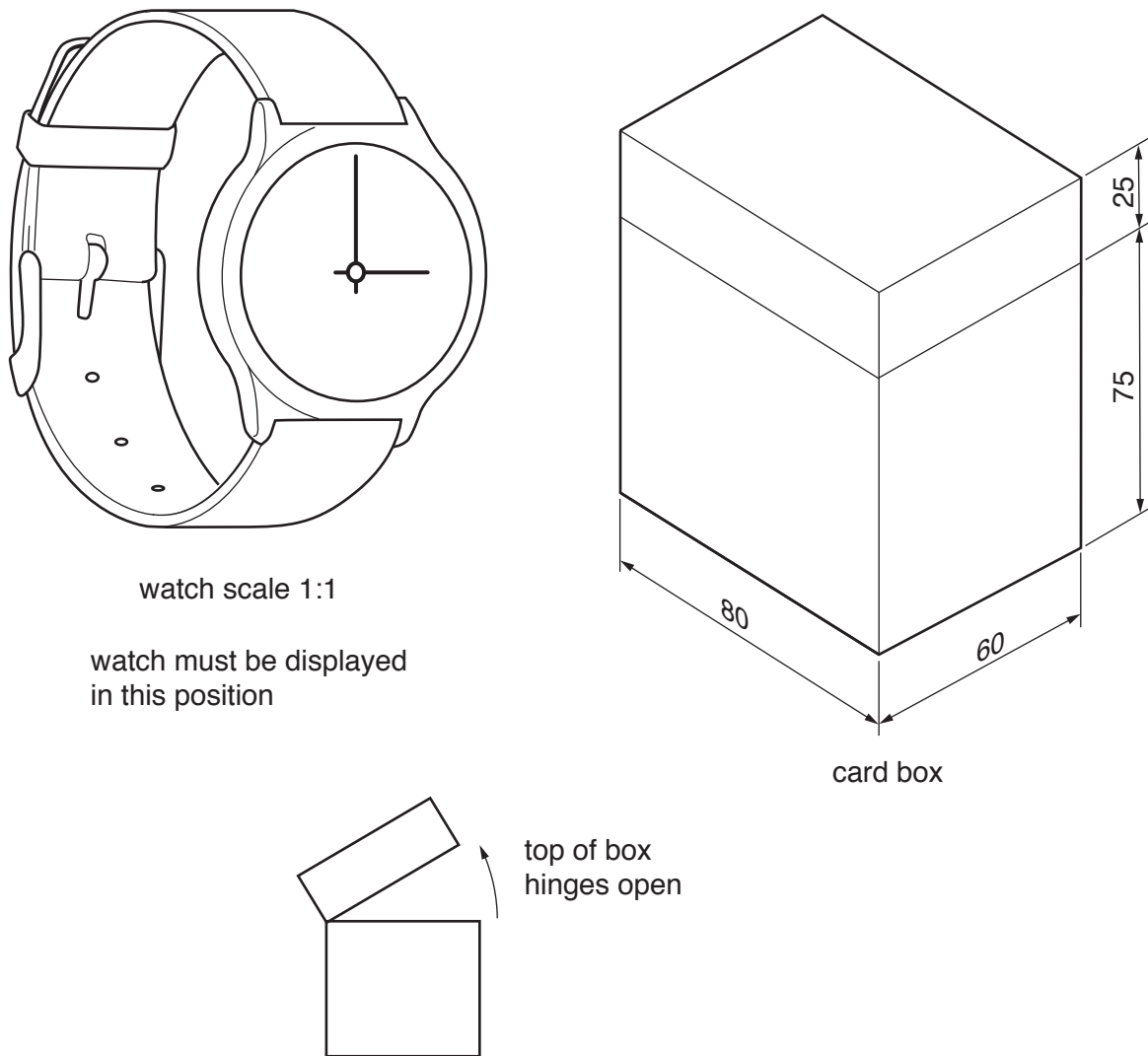

Fig. 8

- (a) Using notes and sketches, **develop** a design for a plastic display stand for the watch. The display stand with the watch on it must fit inside the card box. [20]
- (b) Using notes and sketches, **develop** a design for the card box. It must be possible to open and securely close the box.
The design must be made from a one piece development (net) and include a window so that the watch can be seen when in the closed packaging. Your design work must include details of the one piece development (net) required to make the box. [20]
- (c) Using notes and sketches, **develop** a design for the lettering to go on the box. The company's name is '**Watch the Time**' and the lettering should be in a style that reflects the name. [20]
- (d) Produce a pictorial rendered drawing of the complete packaging which shows all of the features that you have designed in **parts (a)–(c)**. Do not show the watch in this drawing. [20]

- 9 Fig. 9 shows an incomplete design for an outdoor seating facility which will be built in a park or other public space.

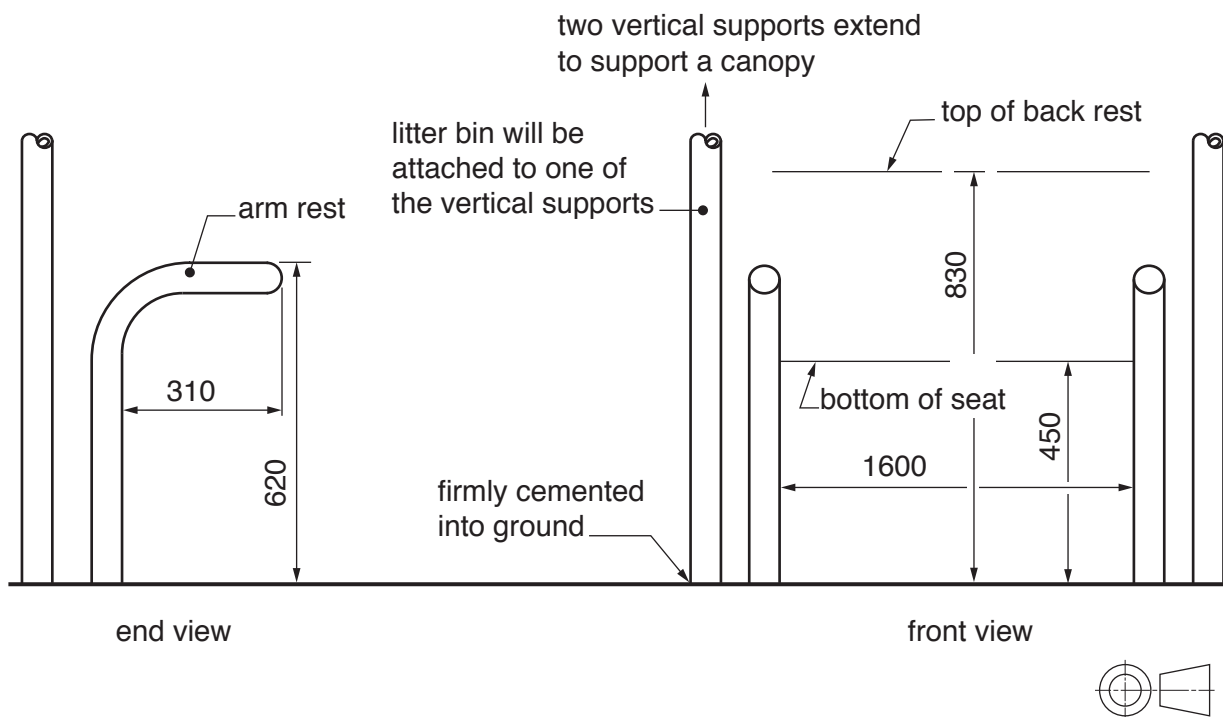

Fig. 9

- (a) Using notes and sketches, **develop** a design for a seat and back rest which will be joined to the arm rests. [20]
- (b) Using notes and sketches, **develop** a design which extends the two vertical supports and forms a canopy which protects people using the seat from the sun and rain. [20]
- (c) Using notes and sketches, **develop** a design for a litter bin which can be attached to one of the vertical supports. The design must prevent litter being blown out of the bin and be easy to empty. [20]
- (d) Produce a pictorial rendered drawing of the complete seating facility which shows all of the features that you have designed in **parts (a)–(c)**. [20]

BLANK PAGE

BLANK PAGE

Permission to reproduce items where third-party owned material protected by copyright is included has been sought and cleared where possible. Every reasonable effort has been made by the publisher (UCLES) to trace copyright holders, but if any items requiring clearance have unwittingly been included, the publisher will be pleased to make amends at the earliest possible opportunity.

To avoid the issue of disclosure of answer-related information to candidates, all copyright acknowledgements are reproduced online in the Cambridge International Examinations Copyright Acknowledgements Booklet. This is produced for each series of examinations and is freely available to download at www.cie.org.uk after the live examination series.

Cambridge International Examinations is part of the Cambridge Assessment Group. Cambridge Assessment is the brand name of University of Cambridge Local Examinations Syndicate (UCLES), which is itself a department of the University of Cambridge.