



Cambridge International AS & A Level

DESIGN & TECHNOLOGY**9705/12**

Paper 1

October/November 2021**3 hours**

You must answer on the answer booklet/paper.

You will need: Answer booklet/A4 paper Coloured pencils
 A3 drawing paper (2 sheets) Extra sheets of A3 drawing paper if needed
 A range of design drawing equipment

INSTRUCTIONS

- Answer **three** questions in total:
 - Section A: answer **one** question on the answer booklet/A4 paper provided.
 - Section B: answer **one** question on the answer booklet/A4 paper provided.
 - Section C: answer **one** question on A3 drawing paper. Use both sides of the paper.
- You may request additional sheets of A3 drawing paper, but only if you have used up both sides of each of the 2 sheets provided.
- If you have been given an answer booklet, follow the instructions on the front cover of the answer booklet.
- Use a black or dark blue pen.
- Write your name, centre number and candidate number on all the work you hand in.
- Do **not** use an erasable pen or correction fluid.
- You may use an HB pencil, or coloured pencils as appropriate, for any diagrams, graphs or rough working.
- At the end of the examination, fasten all your work together. Do **not** use staples, paper clips or glue.

INFORMATION

- The total mark for this paper is 120.
- The number of marks for each question or part question is shown in brackets [].
- All dimensions are in millimetres.

This document has **12** pages. Any blank pages are indicated.

Section A

Answer **one** question from this section on the Answer Booklet/A4 paper provided.

- 1 Fig. 1.1 gives details of a set of mats which are to be made in a school workshop.

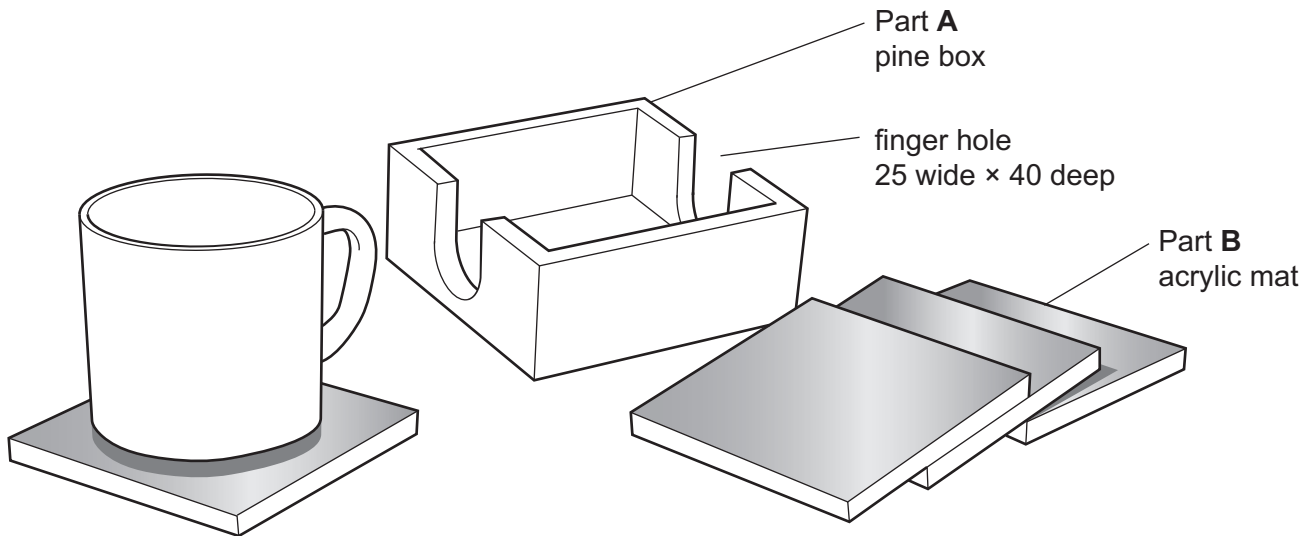

Fig. 1.1

- (a) State **two** properties of acrylic that make it a suitable material for the mat. [2]
- (b) Use notes and sketches to describe how to mark out and cut:
- (i) a joint, other than a butt joint, that could be used on a corner of Part **A** [6]
 - (ii) the finger hole in Part **A**. [6]

You must give details about the tools, equipment and processes involved and the safety precautions that have to be undertaken at each stage.

- (c) Use notes and sketches to show a method of adding the words 'Coffee time' to Part **B**, the acrylic mat. [6]

- 2 Fig. 2.1 gives details of a pop up card which is to be made in a school workshop.

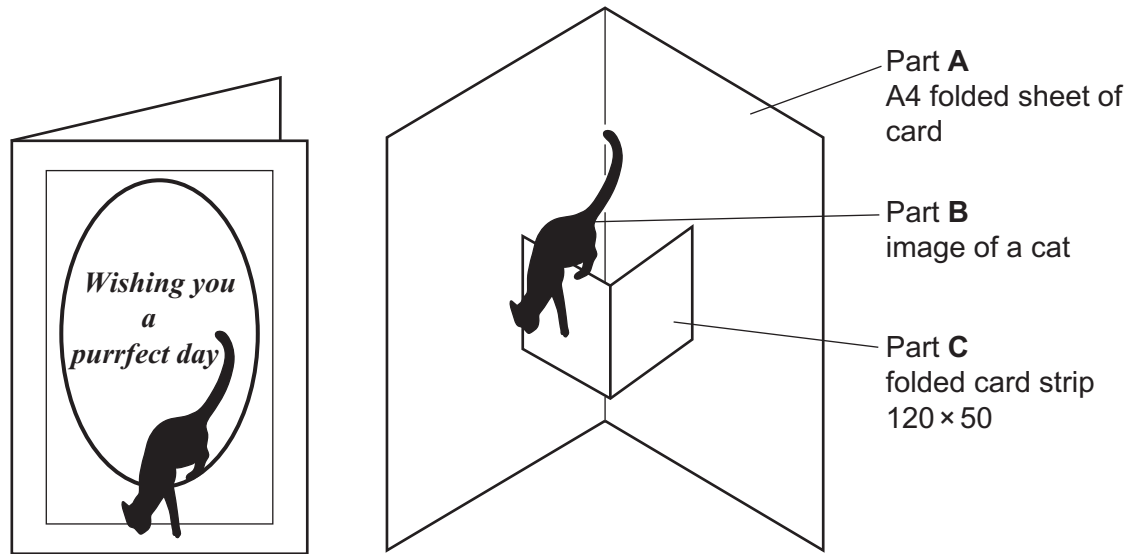

Fig. 2.1

- (a) Use a sketch and notes to show the size of the envelope required for the pop up card. [2]
- (b) Use notes and sketches to describe:
- (i) how Part B could be made in quantity [6]
 - (ii) how Part C could be marked out, cut out and joined to Part A. [6]
- You must give details about the tools, equipment and processes involved and the safety precautions that have to be undertaken at each stage.
- (c) Use notes and sketches to show how Computer Aided Design (CAD) could be used to produce the design on the front of the card. [6]

3 Fig. 3.1 gives details of a metal cramp which is to be made in a school workshop.

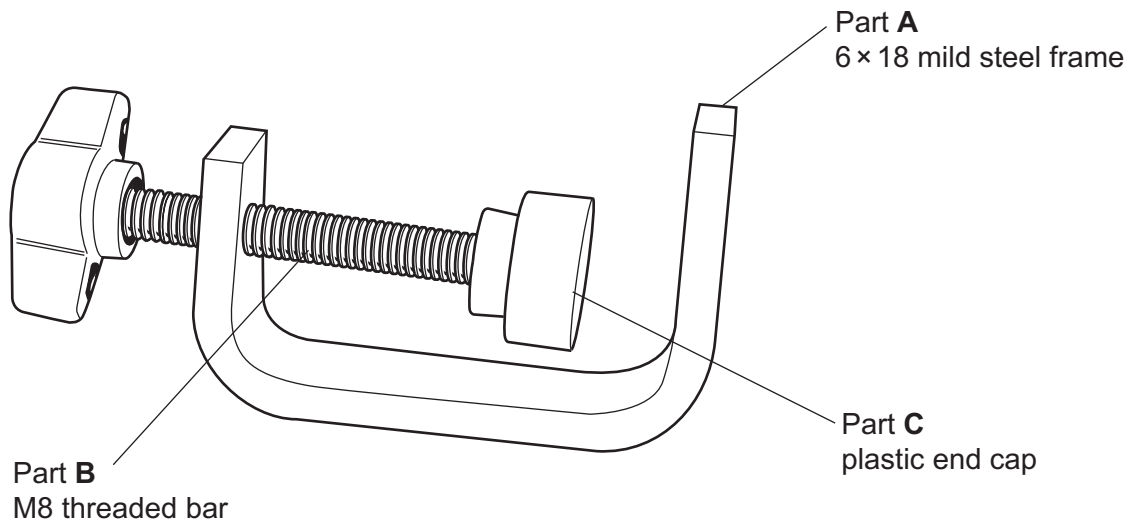

Fig. 3.1

(a) State **two** types of motion used in the cramp. [2]

(b) Use notes and sketches to describe:

(i) how to make Part A [6]

(ii) how to cut the thread on Part B. [6]

You must give details about the tools, equipment and processes involved and the safety precautions that have to be undertaken at each stage.

(c) Use notes and sketches to show a method of making a batch of 500 of Part C, the plastic end cap. [6]

Section B

Answer **one** question from this section on the Answer Booklet/A4 paper provided.

- 4 Fig. 4.1 gives details of a child's high chair made from plywood.

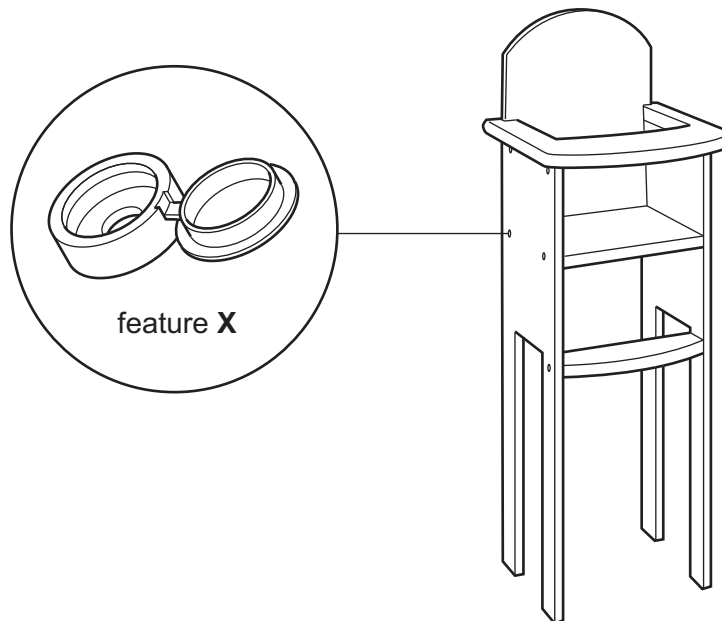

Fig. 4.1

- (a) Explain the function of the design feature shown at **X**. [2]
- (b) Identify and describe **two** problems with the child's high chair. [4]
- (c) Using notes and sketches, explain how the child's high chair would need to be changed to overcome the **two** problems you have identified in **part (b)**. [6]
- (d) Discuss why some furniture, such as a child's high chair, is designed to be mass produced. Your answer should:
- (i) analyse the given situation and identify **three** relevant issues raised by the question [3]
 - (ii) explain why you consider these issues to be relevant [3]
 - (iii) contain specific examples/evidence to support your conclusions. [2]

5 Fig. 5.1 gives details of a paintbrush set.

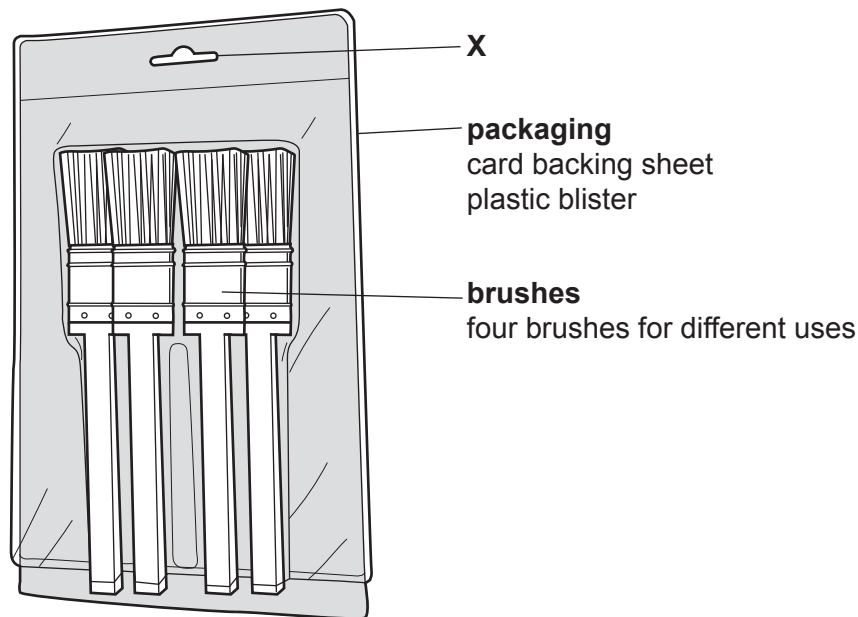

Fig. 5.1

- (a) Explain the function of the design feature shown at **X**. [2]
- (b) Identify and describe **two** problems with the paintbrush set. [4]
- (c) Using notes and sketches, explain how the paintbrush set would need to be changed to overcome the **two** problems you have identified in **part (b)**. [6]
- (d) Discuss why packaging, such as used for the paintbrush set, focuses on function rather than aesthetics. Your answer should:
- (i) analyse the given situation and identify **three** relevant issues raised by the question [3]
 - (ii) explain why you consider these issues to be relevant [3]
 - (iii) contain specific examples/evidence to support your conclusions. [2]

6 Fig. 6.1 gives details of a battery operated torch.

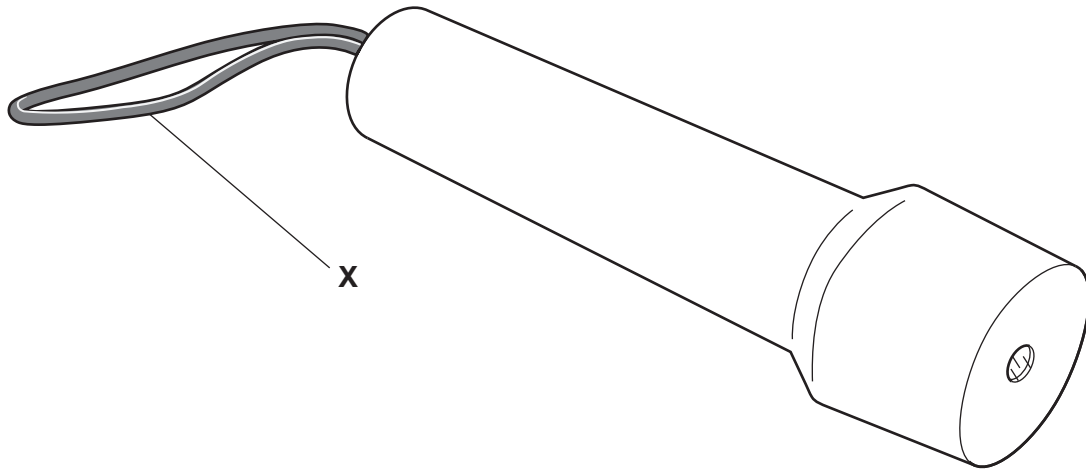

Fig. 6.1

- (a) Explain the function of the design feature shown at X. [2]
- (b) Identify and describe **two** problems with the battery operated torch. [4]
- (c) Using notes and sketches, explain how the battery operated torch would need to be changed to overcome the **two** problems you have identified in **part (b)**. [6]
- (d) Discuss why some electric powered products use energy sources other than batteries. Your answer should:
- (i) analyse the given situation and identify **three** relevant issues raised by the question [3]
 - (ii) explain why you consider these issues to be relevant [3]
 - (iii) contain specific examples/evidence to support your conclusions. [2]

Section C

Answer **one** question from this section on the plain A3 paper provided.

You are provided with two sheets of plain A3 paper. You should use **both** sides of the paper. **Each** of the four parts **(a) – (d)** of the question you choose to answer should take up one side of paper.

When you are asked to **develop** a design you must show, using notes and sketches, the development and evaluation of a **range** of ideas into a single design solution. The design proposal should be annotated to give details about materials, joining methods and important sizes.

7 Fig. 7.1 shows nine Ø10 ball bearings.

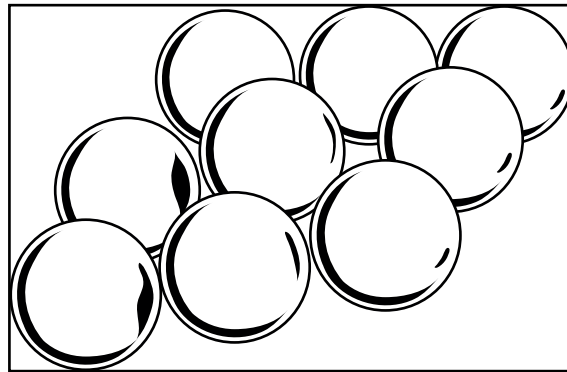

Fig. 7.1

- (a) Use notes and sketches to **develop** a design for a game that uses **three** ball bearings. [20]
- (b) Use notes and sketches to **develop** a design for a carrying case for the game designed in **part (a)**. [20]
- (c) Use notes and sketches to **develop** a design a method of storing the **six** spare ball bearings that attaches to the carrying case designed in **part (b)**. [20]
- (d) Produce a pictorial (3D) rendered drawing of the complete ball bearing game which shows all of the features that you have designed in **parts (a) – (c)**. [20]

- 8 Fig. 8.1 shows a poster for a safari park and the parts of a painting set.



poster



paint pot
 Ø70 at top
 70 high
 Ø60 at bottom



paintbrush
 Ø12
 120 long

Fig. 8.1

- (a) Use notes and sketches to **develop** a design for a child's painting book based upon the animal shapes in the poster. The painting book must be A4 size and consist of six pages. [20]
- (b) Use notes and sketches to **develop** a design for a holder for six pots of paint and a paintbrush. [20]
- (c) Use notes and sketches to **develop** a design for an easy to carry environmentally friendly package for the painting book designed in **part (a)** and holder designed in **part (b)**. [20]
- (d) Produce a pictorial (3D) rendered drawing of the complete painting set which shows all of the features that you have designed in **parts (a) – (c)**. [20]

- 9 Fig. 9.1 shows an incomplete design for a ceiling mounted candle lamp which is made from painted mild steel sheet.

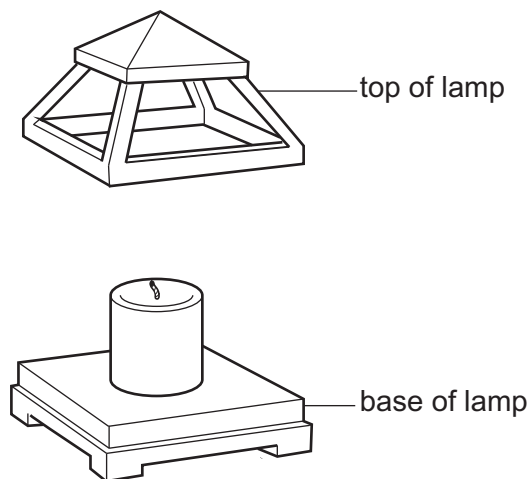

Fig. 9.1

- (a) Use notes and sketches to **develop** a design for a method of joining the top and base of the candle lamp. [20]
- (b) Use notes and sketches to **develop** a design for a mechanism that allows the candle lamp to be hung from a ceiling and the height to be adjusted. [20]
- (c) Use notes and sketches to **develop** a design for an ergonomic handle to be attached to the base of the candle lamp to assist in the height adjustment. [20]
- (d) Produce a pictorial (3D) rendered drawing of the ceiling mounted candle lamp which shows all of the features that you have designed in **parts (a) – (c)**. [20]

BLANK PAGE

Permission to reproduce items where third-party owned material protected by copyright is included has been sought and cleared where possible. Every reasonable effort has been made by the publisher (UCLES) to trace copyright holders, but if any items requiring clearance have unwittingly been included, the publisher will be pleased to make amends at the earliest possible opportunity.

To avoid the issue of disclosure of answer-related information to candidates, all copyright acknowledgements are reproduced online in the Cambridge Assessment International Education Copyright Acknowledgements Booklet. This is produced for each series of examinations and is freely available to download at www.cambridgeinternational.org after the live examination series.

Cambridge Assessment International Education is part of the Cambridge Assessment Group. Cambridge Assessment is the brand name of the University of Cambridge Local Examinations Syndicate (UCLES), which itself is a department of the University of Cambridge.