

Section A

Answer **two** questions from **one** of the Parts **A**, **B** or **C**.

Part A – Product Design

The instruction 'discuss' denotes that you should:

- examine critically the issues raised by the question
- explain and interpret these issues as appropriate
- introduce evidence wherever possible to support conclusions of arguments.

- 1 'Design, if it is to be ecologically responsible and socially responsive, must be revolutionary and radical'.
Discuss the issues raised by this quote and the implications for designers and consumers. [20]
- 2 Fig. 1.1 shows a lampshade with an LED light and a component part of the lampshade.

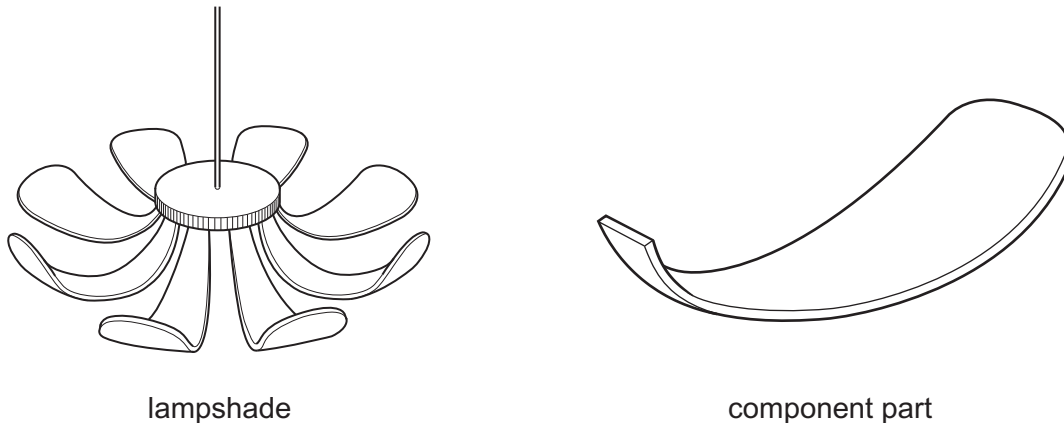

Fig 1.1

- (a) State a suitable material for the component part of the lampshade and give **two** reasons for your choice. [3]
- (b) Use sketches and notes to describe how you would make a prototype component part of the lampshade in a school workshop. [9]
- (c) Explain the changes which may be necessary to the design, the manufacturing method used and the material selected, if 5000 identical components were required. Use sketches and notes to support your answer. [8]

3

3

item: mild steel tube joint
process: brazing

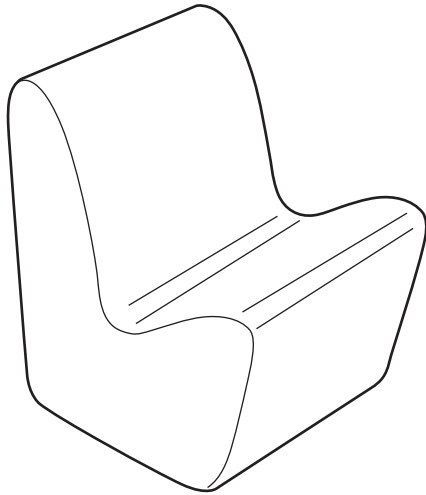
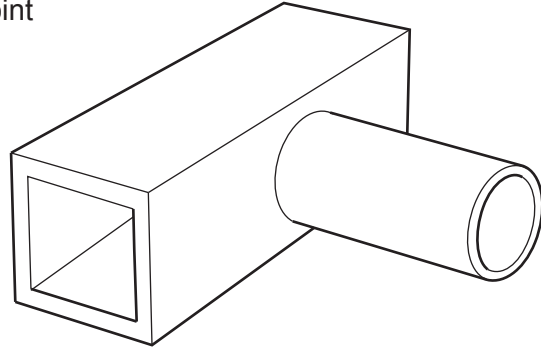

item: chair
process: rotational moulding

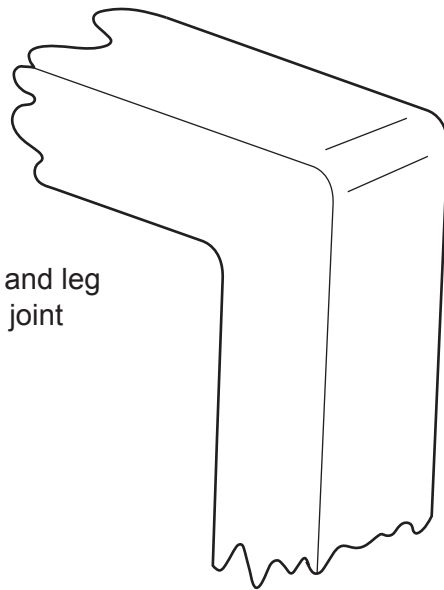

item: corner of chair arm and leg
process: making a bridle joint

Fig. 3.1

Choose **two** of the items shown in Fig. 3.1. For each:

- (a) use sketches and notes to describe how the process has been used in the manufacture of the item [14]
- (b) explain why the process is particularly suitable in the production of the item. [6]

Part B – Practical Technology

4 (a) State what is meant by the following electrical terms:

(i) AC [1]

(ii) DC [1]

(b) Fig. 4.1 shows resistors in part of a circuit.

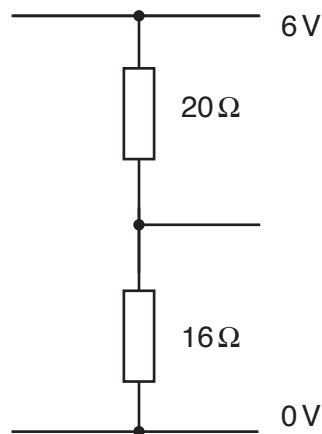

Fig. 4.1

(i) Calculate the current flowing through both resistors. [3]

(ii) Calculate the voltage across the 20Ω resistor. [3]

(c) Explain the benefits and drawbacks of using the following systems in products:

- pneumatics
- hydraulics. [12]

5 (a) The properties of materials dictate their particular suitability for application in products. For **each** of the following, give an example of a specific material used in a product to explain the significance of each property:

- corrosion resistance
- thermal conductivity
- ductility
- brittleness. [16]

(b) Use sketches and notes to describe how a material of your choice can be reinforced. [4]

5

6 Fig. 6.1 shows a gear train.

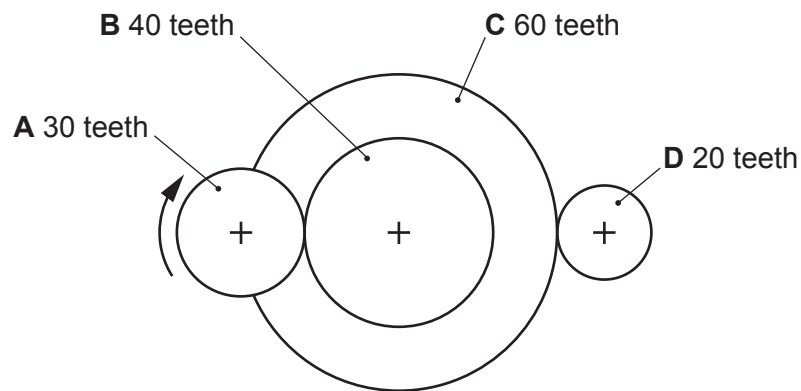

Fig. 6.1

- (a) Gear **A** rotates clockwise. State the direction of gear **D**. [1]
- (b) Calculate the gear ratio of the compound gear train. [3]
- (c) Use sketches and notes to describe:
- a method of converting linear motion to rotary motion
 - a method of transmitting rotary motion through 90° .
- For each, describe in detail how the method works in a product or system. [10]
- (d) Explain how mechanisms can be made to work as efficiently as possible. [6]

Part C – Graphic Products

The instruction 'discuss' denotes that you should:

- examine critically the issues raised by the question
- explain and interpret these issues as appropriate
- introduce evidence wherever possible to support conclusions of arguments.

7 Fig. 7.1 shows an orthographic drawing of a laptop stand.

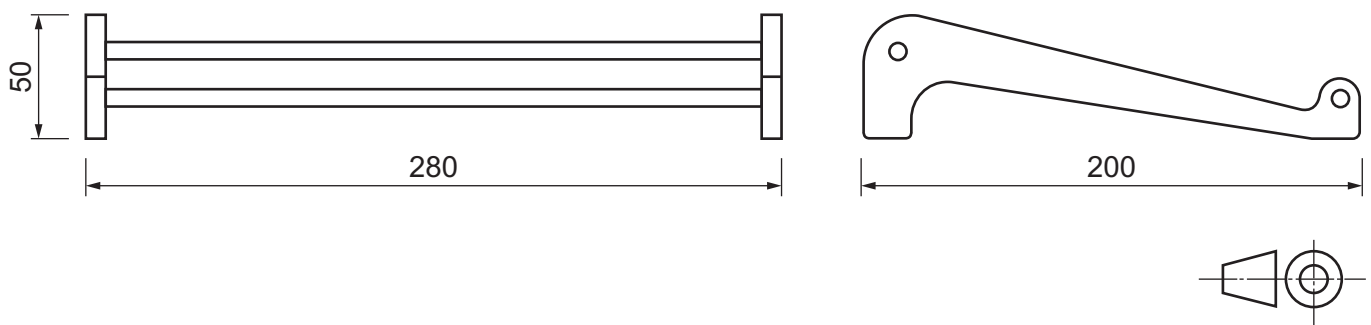

Fig. 7.1

- (a) Draw to a scale of 1:2, a two-point perspective view of the laptop stand. Render the sides to show that they are made from wood. [10]
- (b) Use sketches and notes to explain how you would display a laptop stand in a large computer shop. [10]

- 8 Discuss how aesthetic qualities, unit costs and manufacturing processes influence a designer when designing **one** of the following: [20]
- a desktop point of sale (POS) display for a new brand of perfume
 - packaging for take-away meals
 - an A4 tri-fold leaflet to advertise holidays.

- 9 Fig. 9.1 shows details of a display for three fitness bands. The display is made from card.

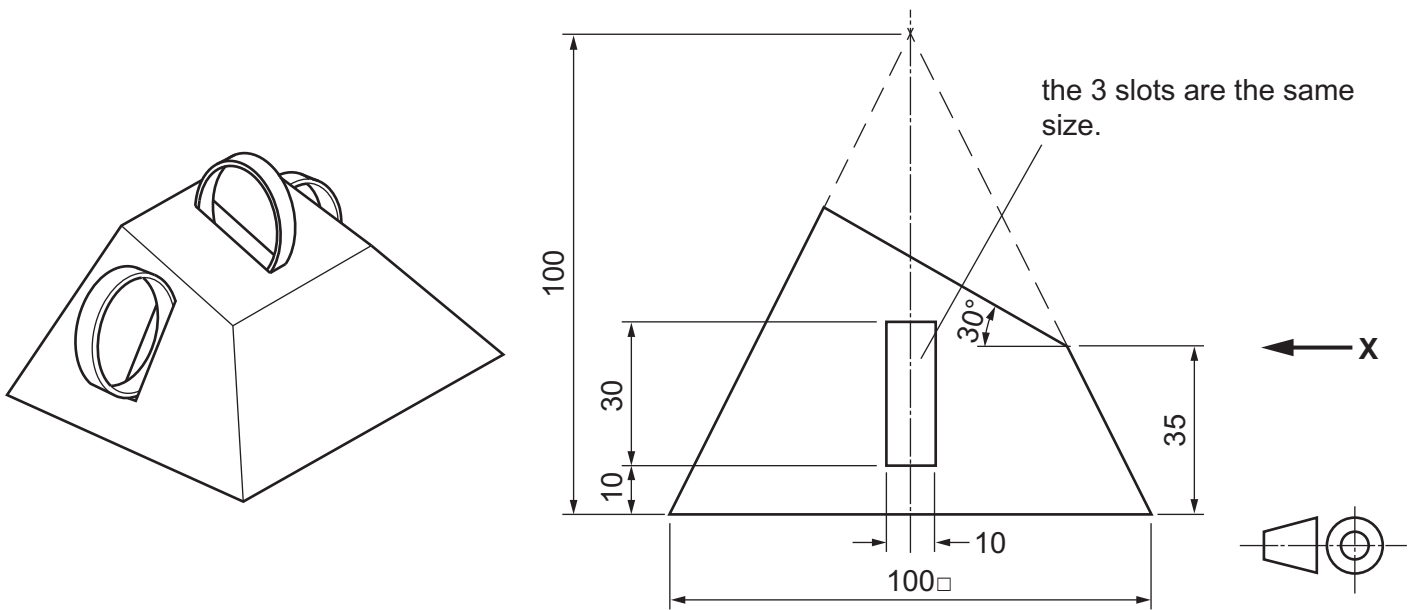

Fig. 9.1

- (a) Draw full size the elevation given, an end elevation from arrow **X** and a plan of the display. [12]
- (b) Draw a development (net) of the display. [8]

Section B

Answer **one** question on the A3 paper provided.

Each question is worth 80 marks.

You should approach the design question of your choice in the following manner:

Analysis

Produce an analysis of the given situation/problem, which may be in written or graphical form. [5]

Specification

From the analysis produce a detailed written specification of the design requirements. Include at least five specification points other than those given in the question. [5]

Exploration

Use bold sketches and brief notes to show your exploration of ideas for a design solution, with reasons for selection. [25]

Development

Show using bold sketches and notes, the development, reasoning and composition of ideas into a single design proposal. Give details of materials, constructional and other relevant technical details. [25]

Proposed solution

Produce drawings of an appropriate kind to show the complete solution. [15]

Evaluation

Give a written evaluation of the final design solution. [5]

- 10** Many families enjoy visiting the beach. Carrying items across a beach to a desired spot can be difficult.

You are to design a product that will:

- transport items across a beach and provide a dual purpose
- fit easily in a car.

[80]

- 11** A games company wishes to expand its product line and produce a timer to be included in games. Design an imaginative timer for a game of your choice, incorporating a mechanical and/or electronic system.

The timer must:

- provide at least two different time durations
- be based on the theme of the chosen game.

[80]

- 12** A school has been asked to raise awareness of local or national environmental concerns.

You are to design a free standing eco-display to be placed at the entrance of the school.

The display must:

- take up no more than 1 m × 1.5 m floor space
- include an interactive feature.

[80]

BLANK PAGE

Permission to reproduce items where third-party owned material protected by copyright is included has been sought and cleared where possible. Every reasonable effort has been made by the publisher (UCLES) to trace copyright holders, but if any items requiring clearance have unwittingly been included, the publisher will be pleased to make amends at the earliest possible opportunity.

To avoid the issue of disclosure of answer-related information to candidates, all copyright acknowledgements are reproduced online in the Cambridge Assessment International Education Copyright Acknowledgements Booklet. This is produced for each series of examinations and is freely available to download at www.cambridgeinternational.org after the live examination series.

Cambridge Assessment International Education is part of Cambridge Assessment. Cambridge Assessment is the brand name of the University of Cambridge Local Examinations Syndicate (UCLES), which is a department of the University of Cambridge.