



**Cambridge International Examinations**  
Cambridge International General Certificate of Secondary Education

CANDIDATE  
NAME

CENTRE  
NUMBER

--	--	--	--	--

CANDIDATE  
NUMBER

--	--	--	--

**CHEMISTRY**

**0620/33**

Paper 3 Theory (Core)

**May/June 2018**

**1 hour 15 minutes**

Candidates answer on the Question Paper.

No Additional Materials are required.

**READ THESE INSTRUCTIONS FIRST**

Write your Centre number, candidate number and name on all the work you hand in.

Write in dark blue or black pen.

You may use an HB pencil for any diagrams or graphs.

Do not use staples, paper clips, glue or correction fluid.

DO **NOT** WRITE IN ANY BARCODES.

Answer **all** questions.

Electronic calculators may be used.

A copy of the Periodic Table is printed on page 20.

You may lose marks if you do not show your working or if you do not use appropriate units.

At the end of the examination, fasten all your work securely together.

The number of marks is given in brackets [ ] at the end of each question or part question.

The syllabus is approved for use in England, Wales and Northern Ireland as a Cambridge International Level 1/Level 2 Certificate.

This document consists of **17** printed pages and **3** blank pages.



1 The names of seven gases are given.

ammonia  
ethene  
helium  
hydrogen  
hydrogen chloride  
methane  
nitrogen

(a) Answer the following questions about these gases.  
Each gas may be used once, more than once or not at all.  
State which gas:

(i) forms an acidic solution in water

..... [1]

(ii) is monatomic

..... [1]

(iii) forms 78% of clean dry air

..... [1]

(iv) is the main constituent of natural gas

..... [1]

(v) has molecules which each contain 14 protons.

..... [1]

(b) (i) Give the names of **two** elements in the list.

..... and ..... [1]

(ii) What is meant by the term *element*?

..... [1]

3

- (c) Complete the dot-and-cross diagram to show the electron arrangement in a molecule of hydrogen chloride. Show outer electrons only.

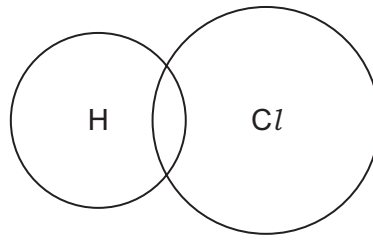

[2]

[Total: 9]

- 2 (a) The table shows the percentage by volume of each of the gases present in the exhaust gases from a petrol engine and a diesel engine.

name	percentage by volume from a petrol engine	percentage by volume from a diesel engine
nitrogen	72.00	67.00
carbon dioxide	14.00	
water vapour	12.00	11.00
carbon monoxide	1.50	0.05
oxides of nitrogen	0.25	0.70
hydrocarbons	0.24	0.22
sulfur dioxide	0.01	0.03
oxygen	0.00	9.00
	total 100.00	total 100.00

- (i) In the diesel engine, nitrogen, carbon dioxide and water vapour account for 90.00% of the exhaust gases by volume.

Calculate the percentage by volume of carbon dioxide in the exhaust gases from the diesel engine.

.....% [1]

- (ii) Describe **three** ways in which the composition of the exhaust gases from the petrol engine differ from the composition of the exhaust gases from the diesel engine.

1 .....

2 .....

3 .....

[3]

- (iii) Give **one** adverse effect of sulfur dioxide on health.

..... [1]

- (b) Complete the sentences about the separation of petroleum into fractions using words from the list.

**boiling    crystallisation    density    distillation    kerosene    poly(ethene)**

Fractional ..... of petroleum produces fractions such as gasoline, diesel oil and ..... . Within each fraction, the molecules have a particular range of ..... points.

[3]

- (c) Balance the chemical equation for the complete combustion of propane.

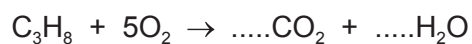

[2]

[Total: 10]

3 This question is about cobalt and its compounds.

- (a) A coloured crystal of cobalt(II) chloride was placed at the bottom of a beaker containing water. After 2 days, the colour had spread throughout the water.

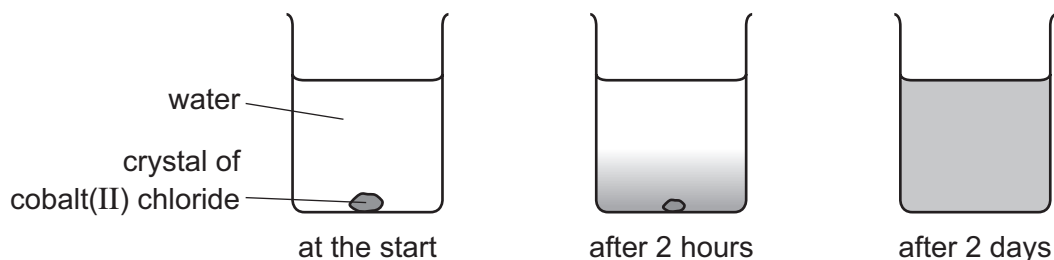

Explain these observations using the kinetic particle model.

.....

.....

.....

.....

..... [3]

- (b) Cobalt(II) chloride can be used to test for the presence of water.

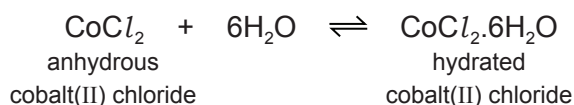

- (i) What is meant by the symbol  $\rightleftharpoons$ ?

..... [1]

- (ii) Describe how the colour of anhydrous cobalt(II) chloride changes when water is added to it.

from ..... to ..... [2]

- (c) A compound of cobalt can be represented by the structure shown.

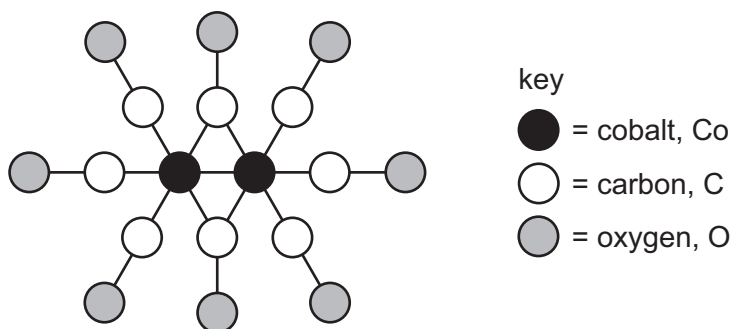

Deduce the molecular formula of this compound showing the number of cobalt, carbon and oxygen atoms.

..... [1]

(d) The table compares the reactivity of cobalt with that of three other metals.

metal	reactivity with cold water	reactivity with steam
barium	reacts rapidly	
cobalt	no reaction	reacts slowly when heated
magnesium	reacts very slowly	reacts rapidly
zinc	no reaction	reacts easily when heated

Use this information to put the metals in order of their reactivity. Put the least reactive metal first.

least reactive  $\xrightarrow{\hspace{15em}}$  most reactive

[2]

(e) Cobalt is a transition element. Lithium is an element in Group I of the Periodic Table.

Describe **three** ways in which the properties of cobalt differ from those of lithium.

- 1 .....
- 2 .....
- 3 .....

[2]

(f) When cobalt(II) oxide, CoO, is heated in air, an oxide with the formula  $\text{Co}_3\text{O}_4$  is formed.

Balance the chemical equation for this reaction.

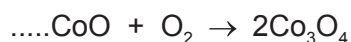

[1]

(g) When  $\text{Co}_3\text{O}_4$  is heated with hydrogen, cobalt metal can be formed.

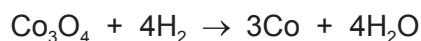

How does this equation show that  $\text{Co}_3\text{O}_4$  is reduced?

- .....
- ..... [1]

[Total: 13]

4 This question is about alcohols.

(a) The structure of compound **P** is shown.

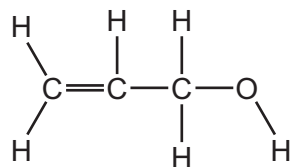

(i) What feature of the structure of compound **P** shows that it is unsaturated?

..... [1]

(ii) Describe how the colour of aqueous bromine changes when an excess of compound **P** is added to it.

from ..... to ..... [2]

(iii) The melting point of compound **P** is  $-129^{\circ}\text{C}$ .  
The boiling point of compound **P** is  $97^{\circ}\text{C}$ .

What is the physical state of compound **P** at  $-120^{\circ}\text{C}$ ?  
Explain your answer.

.....  
..... [2]

(b) Ethanol is an alcohol with two carbon atoms.

(i) Draw the structure of ethanol showing all of the atoms and all of the bonds.

[1]



- (ii) Ethanol can be manufactured by fermentation.

Complete the sentences about fermentation using words from the list.

30 °C                      300 °C                      distillation    electrolysis  
elements                      enzymes                      salt                      sugar

A flask containing ..... solution and yeast is heated to .....

The yeast contains ..... which catalyse the reaction. The ethanol is separated by ..... [4]

- (iii) Ethanol can be used as a fuel.

Give **one** other use of ethanol in industry.

..... [1]

- (iv) The energy level diagram for the complete combustion of ethanol is shown.

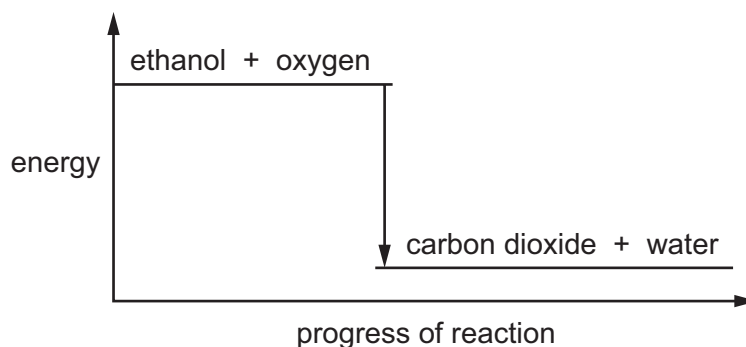

Explain how this diagram shows that the reaction is exothermic.

..... [1]

- (v) Carbon dioxide and water can be formed when ethanol burns in a limited supply of air.

State the name of **two** other products which can be formed when ethanol burns in a limited supply of air.

..... and ..... [2]

[Total: 14]

- 5 (a) Molten lead(II) bromide can be electrolysed using the apparatus shown.

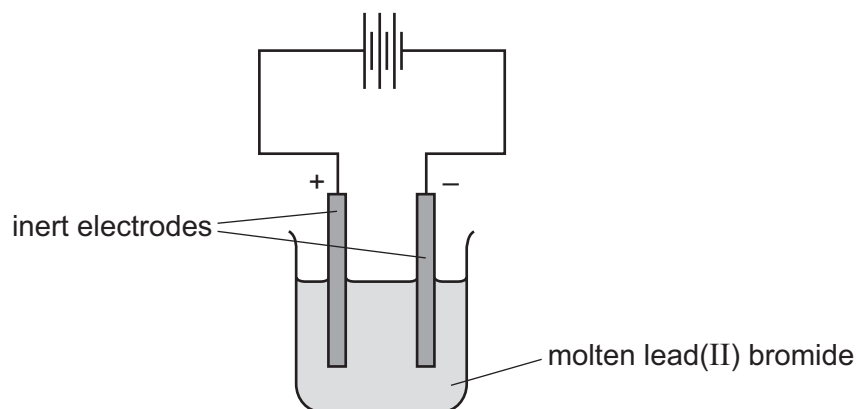

The negative electrode is called the cathode.

State the name of the positive electrode.

..... [1]

- (b) Predict the products of the electrolysis of molten lead(II) bromide at:

the negative electrode .....

the positive electrode. ....

[2]

- (c) Lead(II) bromide is insoluble in cold water.  
Sodium bromide is soluble in cold water.

Describe how you could obtain crystals of sodium bromide from a mixture of solid lead(II) bromide and solid sodium bromide.

.....  
 .....  
 .....  
 ..... [3]

- (d) When chlorine is bubbled through a colourless aqueous solution of sodium bromide, the solution turns orange-brown.

Name the orange-brown substance. Suggest, using ideas about reactivity of the halogens, why the reaction occurs.

orange-brown substance .....

why the reaction occurs .....

..... [2]

(e) What is the colour of the precipitate formed when aqueous silver nitrate is added to aqueous sodium bromide?

..... [1]

(f) Complete the sentence about the formation of a chloride ion from a chlorine atom.

A chloride ion is formed when a chlorine atom gains one ..... [1]

[Total: 10]

6 This question is about isotopes.

(a) An atom of an isotope of oxygen is represented by the symbol shown.



Describe the structure of an atom of this isotope of oxygen.

In your answer, include:

- the position of the protons, neutrons and electrons in the atom
- the number of protons, neutrons and electrons present in the atom.

.....

.....

.....

.....

.....

.....

.....

..... [5]

(b) Which **two** statements about isotopes are correct?  
Tick **two** boxes.

Isotopes of the same element have different numbers of protons.

Isotopes of the same element have different numbers of neutrons.

Isotopes are always radioactive.

The isotope  ${}^{235}_{92}\text{U}$  is a source of energy.

${}^{14}_6\text{C}$  and  ${}^{14}_7\text{N}$  are isotopes of each other.

[2]

(c) What is meant by the term *nucleon number*?

.....

..... [1]

[Total: 8]

7 This question is about Group I elements and their compounds.

(a) The properties of some Group I elements are shown in the table.

element	melting point / °C	relative hardness	observations when it reacts with cold water
lithium	181	23	
sodium	98	3	rapid bubbling but does <b>not</b> burst into flame
potassium	63		very rapid bubbling and bursts into flame
rubidium		1	bursts into flame and explodes

(i) Complete the table to estimate:

- the relative hardness of potassium
- the melting point of rubidium.

[2]

(ii) Use the information in the table to predict what you would observe when lithium reacts with cold water.

..... [1]

(b) Write the electronic structure of a sodium atom.

..... [1]

(c) When sodium reacts with water, an alkaline solution is formed.

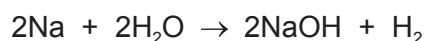

(i) Use the information in the equation to explain why the solution formed is alkaline.

..... [1]

(ii) Describe how you could use a named indicator solution to show that the solution is alkaline.

.....  
 ..... [2]

14

(d) Sodium tetrahydridoborate,  $\text{NaBH}_4$ , is an ionic compound.

Calculate the relative formula mass of  $\text{NaBH}_4$ .

Show all your working.

Use your Periodic Table to help you.

relative formula mass = ..... [2]

[Total: 9]

- 8 The apparatus shown is used to investigate the rate of reaction between calcium carbonate and hydrochloric acid at 30 °C.

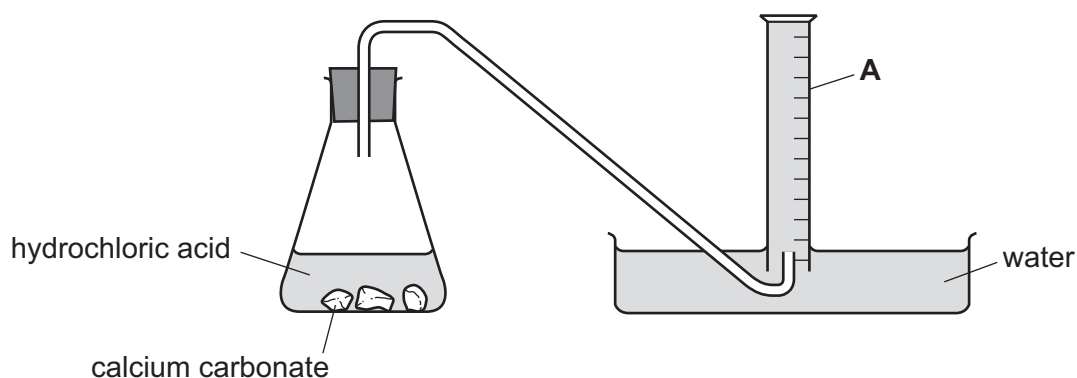

- (a) Name the piece of apparatus labelled **A** in the diagram.

..... [1]

- (b) Describe how this apparatus can be used to find the rate of reaction.

.....  
 .....  
 ..... [2]

- (c) The experiment is repeated at 20 °C. All other conditions are kept the same.

How does the decrease in temperature affect the rate of reaction?

..... [1]

- (d) The experiment is repeated using the same mass of different size pieces of calcium carbonate. All other conditions are kept the same.

The sizes of the pieces of calcium carbonate are:

- large pieces
- small pieces
- powder

Complete the table by writing the sizes of the pieces in the first column.

size of the pieces of calcium carbonate	initial rate of reaction in cm <sup>3</sup> gas/s
	5
	2
	12

[1]

(e) Give the names of the **three** products formed when calcium carbonate reacts with hydrochloric acid.

1 .....

2 .....

3 .....

[2]

[Total: 7]



**BLANK PAGE**

**BLANK PAGE**

**BLANK PAGE**

---

Permission to reproduce items where third-party owned material protected by copyright is included has been sought and cleared where possible. Every reasonable effort has been made by the publisher (UCLES) to trace copyright holders, but if any items requiring clearance have unwittingly been included, the publisher will be pleased to make amends at the earliest possible opportunity.

To avoid the issue of disclosure of answer-related information to candidates, all copyright acknowledgements are reproduced online in the Cambridge International Examinations Copyright Acknowledgements Booklet. This is produced for each series of examinations and is freely available to download at [www.cie.org.uk](http://www.cie.org.uk) after the live examination series.

Cambridge International Examinations is part of the Cambridge Assessment Group. Cambridge Assessment is the brand name of University of Cambridge Local Examinations Syndicate (UCLES), which is itself a department of the University of Cambridge.

