



UNIVERSITY OF CAMBRIDGE INTERNATIONAL EXAMINATIONS  
International General Certificate of Secondary Education

CANDIDATE NAME

CENTRE NUMBER

CANDIDATE NUMBER

\* 9 5 7 0 2 4 0 2 9 8 \*

**DESIGN AND TECHNOLOGY**

0445/03

Paper 3 Resistant Materials

October/November 2009

1 hour

Candidates answer on the Question Paper.

No Additional Materials are required.

To be taken together with Paper 1 in one session of 2 hours 15 minutes.

**READ THESE INSTRUCTIONS FIRST**

Write your Centre number, candidate number and name on all the work you hand in.  
Write in blue or black pen.  
You may use a soft pencil for any diagrams, graphs or rough working.  
Do not use staples, paper clips, highlighters, glue or correction fluid.  
DO NOT WRITE IN ANY BARCODES.

**Section A**

Answer **all** questions in this section.

**Section B**

Answer **one** question in this section.

You may use a calculator.

The total of the marks for this paper is 50.

The number of marks is given in brackets [ ] at the end of each question or part question.

For Examiner's Use	
Section A	
Section B	
Total	

This document consists of 17 printed pages and 3 blank pages.

**Section A**

Answer **all** questions in this section.

1 (a) Fig. 1 shows a solid wood frame.

Draw on Fig. 1 to show how the frame would be cramped together for gluing.

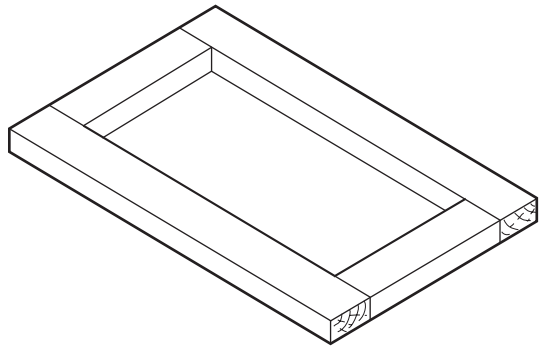

**Fig. 1**

[2]

(b) Name the type of cramp used.

..... [1]

2 Fig. 2 shows thin sheet metal being bent to shape.

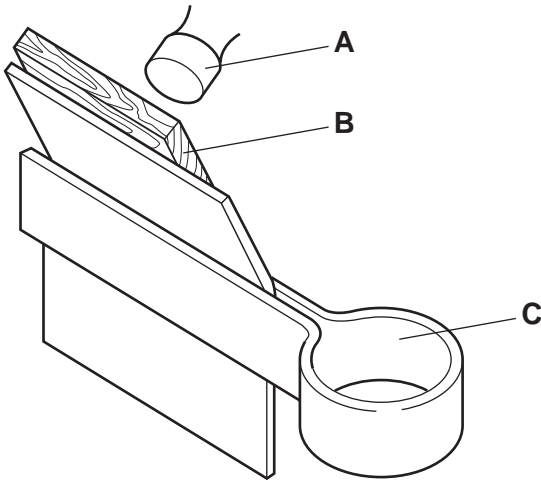

**Fig. 2**

Name the tools or equipment labelled **A**, **B** and **C**.

**A** ..... [1]

**B** ..... [1]

**C** ..... [1]

3

3 Fig. 3 shows an exploded view of a sheet of plywood.

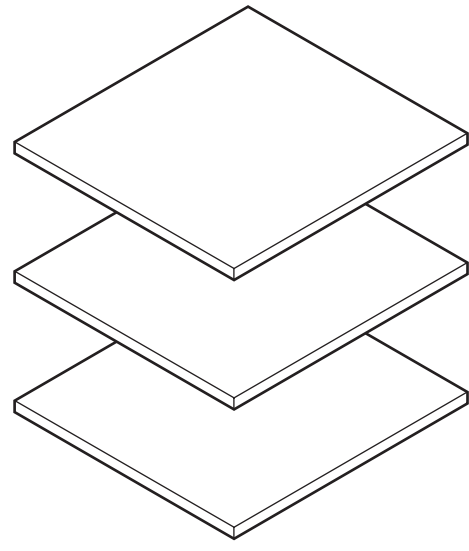
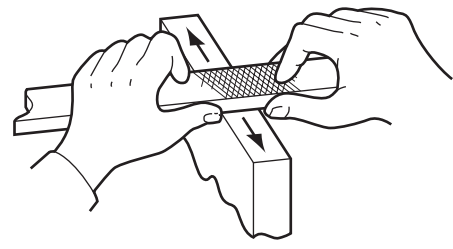

Fig. 3

Draw the grain direction on each of the layers (plies) to show how plywood is constructed. [2]

4 Name the method of filing shown below.



Method of filing ..... [1]

5 Describe **two** methods of planing the end grain shown below without it splitting.

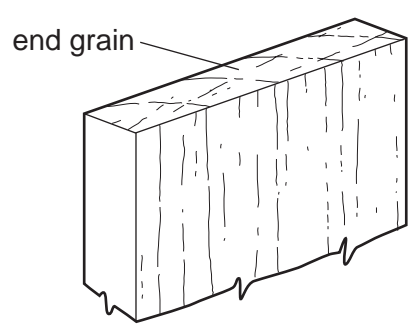

Method 1 .....

..... [1]

Method 2 .....

..... [1]

6

4

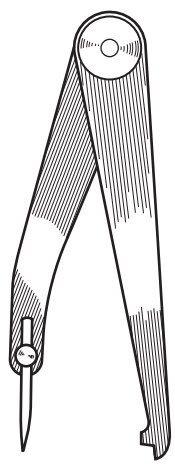

Fig. 4

(a) Name the marking out tool shown in Fig. 4 and describe how it would be used.

.....  
..... [2]

(b) Draw a steel rule to the marking out tool in Fig. 4 to show how it would be set to the required distance. [1]

7 Complete Fig. 5 to show a finger (comb) joint.

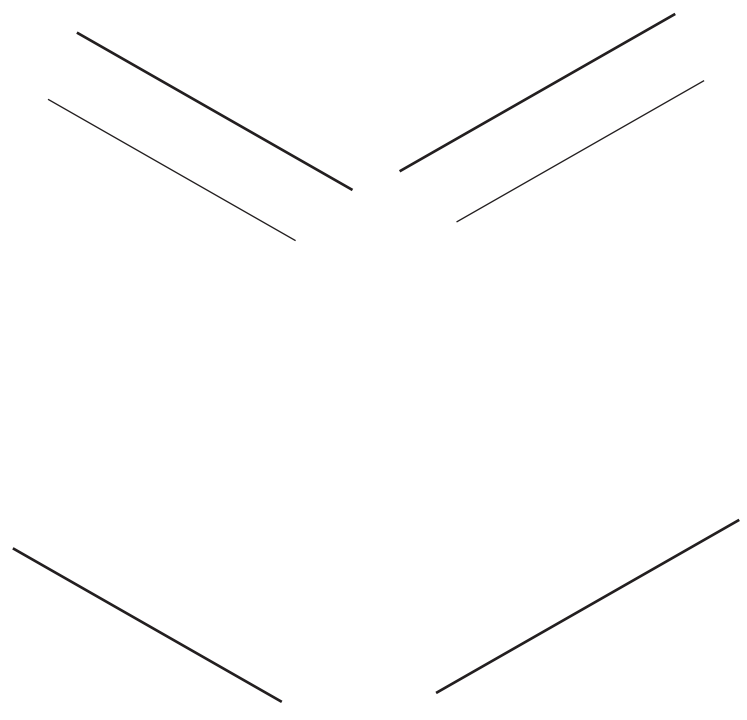

Fig. 5

[3]

8 Name a suitable specific finish for:  
a solid wood table top;

..... [1]

a wooden chopping board for vegetables.

..... [1]

9 Name an appropriate method of manufacture for each of the following plastic products:

soft drinks bottle;

..... [1]

canoe;

..... [1]

bucket.

..... [1]

10 Fig. 6 shows a centre lathe.

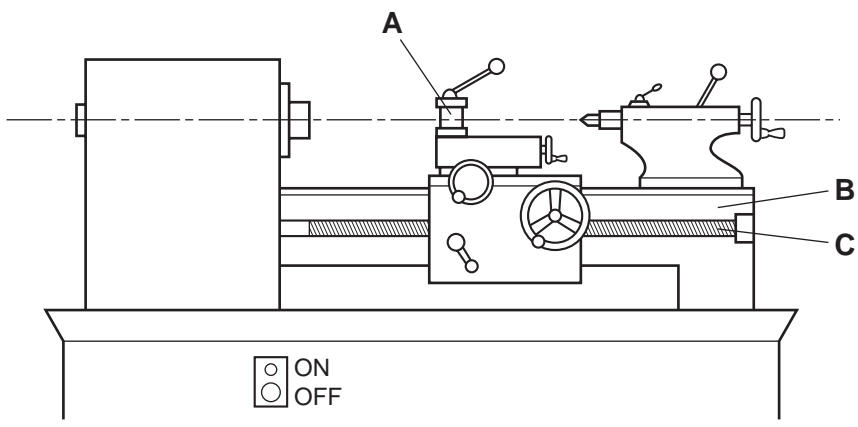

Fig. 6

Name the parts of the centre lathe labelled A, B and C.

A ..... [1]

B ..... [1]

C ..... [1]

Section B

Answer **one** question from this section.

11 Fig. 7 shows details of a wind chime that will be hung from a tree.

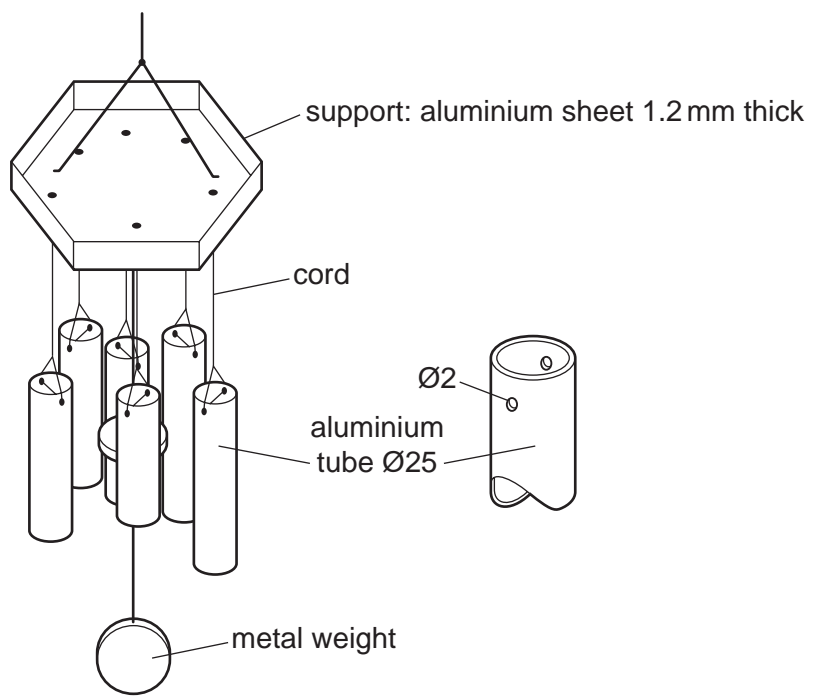

Fig. 7

(a) Give **two** reasons why aluminium is a suitable metal for the wind chime.

1 ..... [1]

2 ..... [1]

(b) Fig. 8 shows the development (net) of the wind chime support marked out on sheet aluminium.

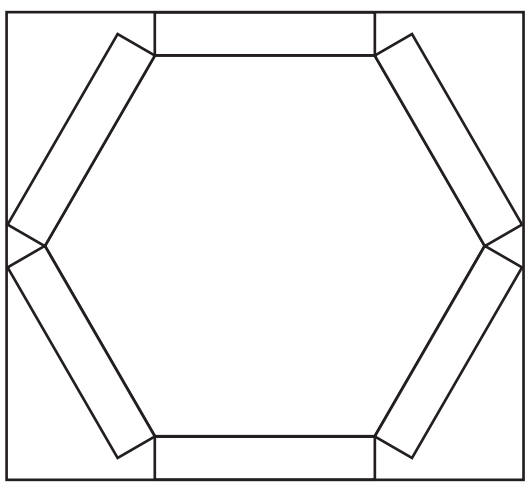

Fig. 8

(i) Name **two** tools used to mark out the development (net).

1 .....

2 ..... [1]

(ii) Give **one** benefit of using a template when marking out the development (net).

..... [1]

(iii) Use sketches and notes to show how the development (net) could be cut out.

[3]

(c) The wind chimes are made from different lengths of Ø25 aluminium tube.

Use sketches and notes to design a jig that would enable three different lengths: 100, 150 and 200 mm, to be sawn from a length of aluminium tube.

Your design must show how the metal tube is held securely while it is sawn to length.

[6]

(d) Fig. 9 shows an incomplete sectional view of the jaws of a machine vice used to hold work that is being drilled.

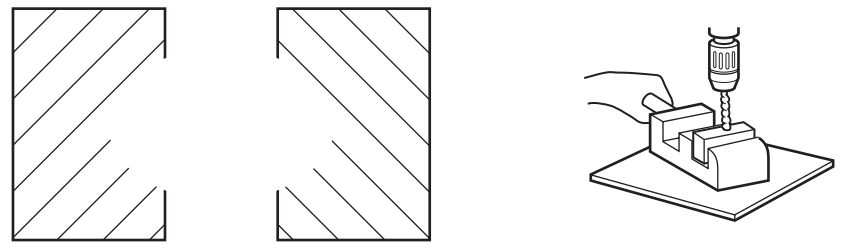

Fig. 9

(i) Complete Fig. 9 to show how the shape of the jaws holds round tube for drilling. [2]

(ii) Explain the purpose of a centre punch used before drilling holes in metal.

.....

.....

..... [2]

(e) (i) Name a suitable finish, other than paint, for the aluminium parts.

..... [1]

(ii) Describe how the aluminium would be prepared before applying the finish you have named in part (i).

.....

..... [2]



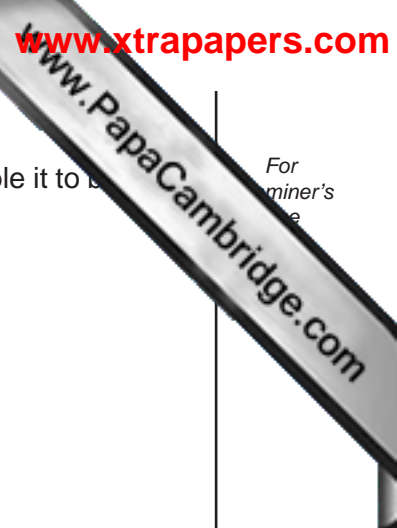

For  
miner's  
e

- (f) Use sketches and notes to show a modification to the wind chime to enable it to be attached to a wall.

[4]

12 Fig. 10 shows an incomplete design for a wall mounted DVD rack.

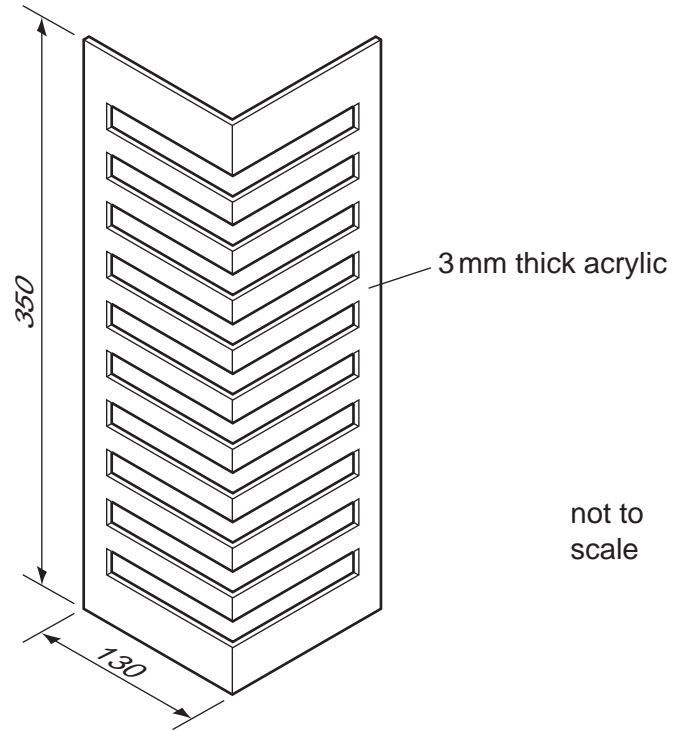

Fig. 10

(a) State **two** items of research a designer would need to carry out before designing the DVD rack.

1 ..... [1]

2 ..... [1]

(b) Before the DVD rack is manufactured, a 'test' slot is cut by hand.

Fig. 11 shows a test slot cut out of a piece of 3 mm thick acrylic sheet.

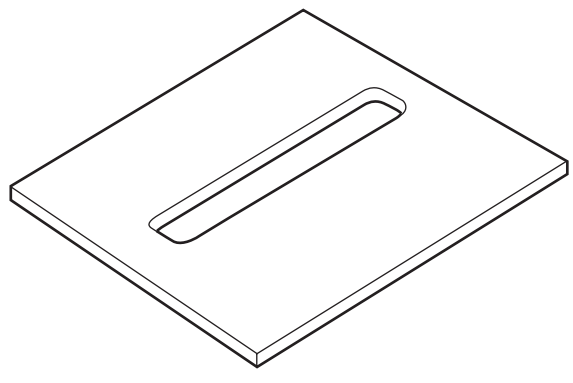

Fig. 11

(i) Complete the table below by naming the processes and the tools and/or equipment used when marking out and cutting the test slot.

Stages	Process	Tools/equipment used
1	Marking out	
2		
3		
4		

[7]

(ii) State **one** possible problem when working with acrylic and describe the action you would take to overcome it.

Problem .....

..... [1]

Action .....

..... [1]

(c) (i) Name **two** tools or items of equipment used to finish the edges of the acrylic sheet.

1 ..... [1]

2 ..... [1]

(ii) Give **one** reason why the edges of the acrylic would be finished before bending it to shape.

..... [1]

(d) Fig. 12 shows a sheet of acrylic with slots cut out. It is marked out ready to be bent to shape.

Use sketches and notes to show how the sheet of acrylic could be bent to shape.

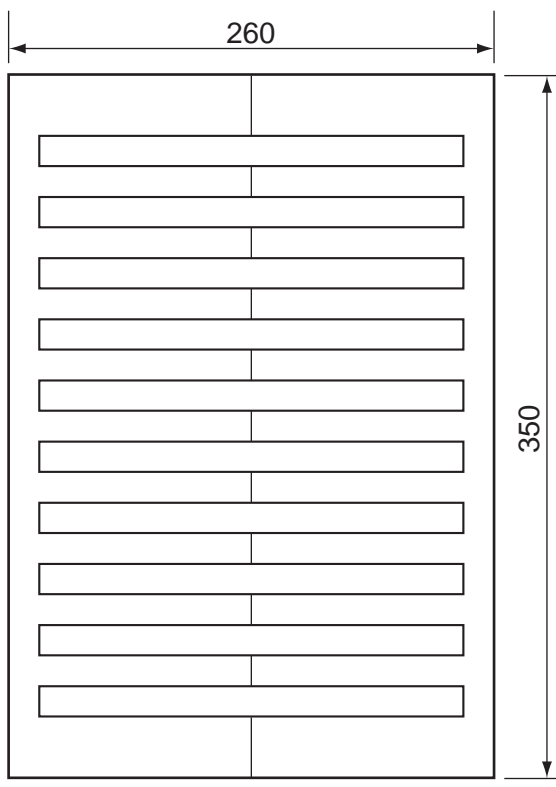

not to  
scale

Fig. 12

(e) The DVD rack shown in Fig. 10 is to be wall mounted.

Use sketches and notes to show how the design could be modified so that it could be wall mounted.

Include details of any materials, constructions and fittings used.

For  
miner's  
e

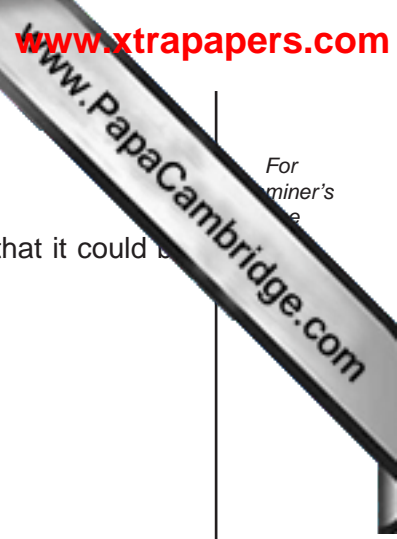

[5]

13 Fig. 13 shows an incomplete design for a child's push-along truck.

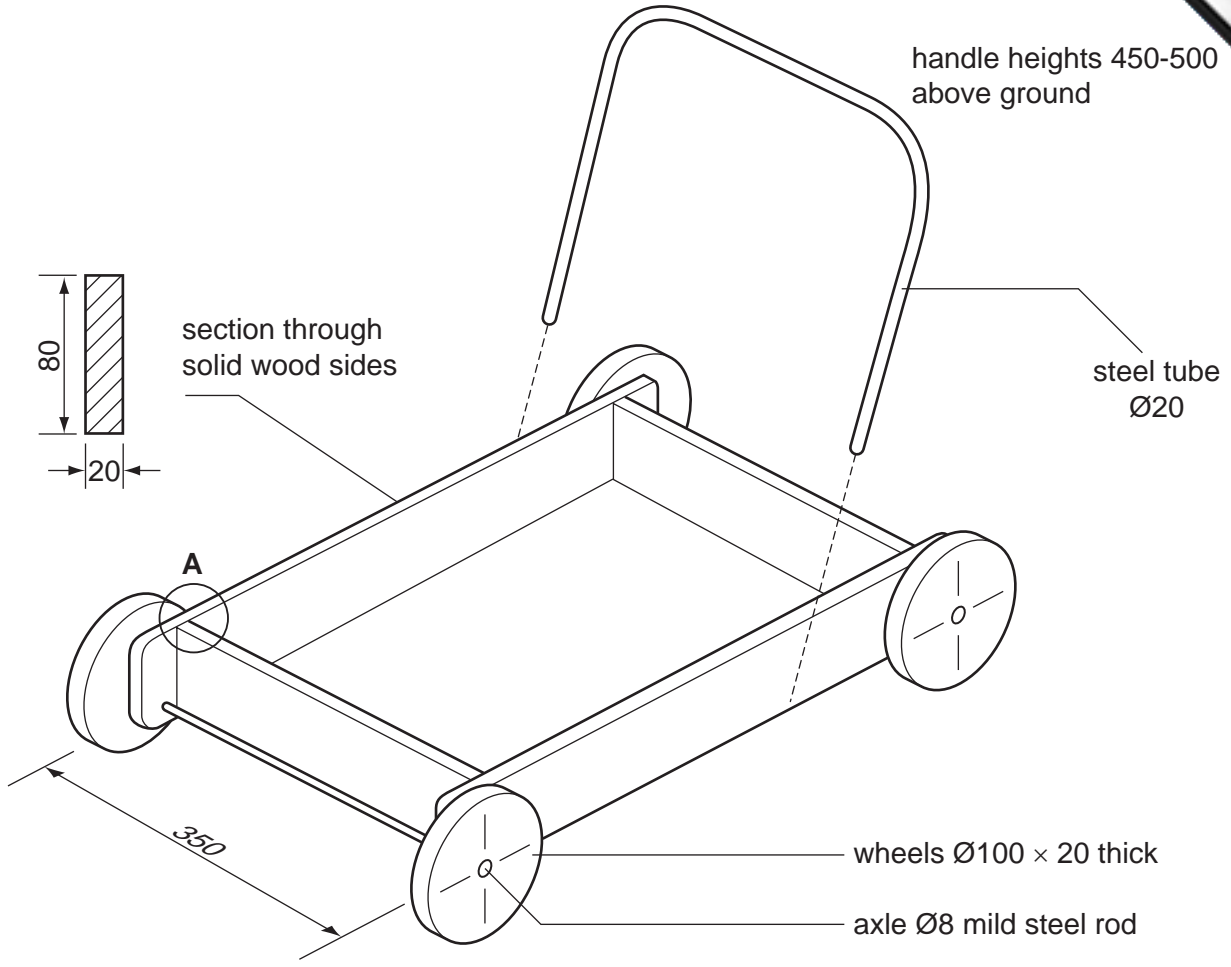
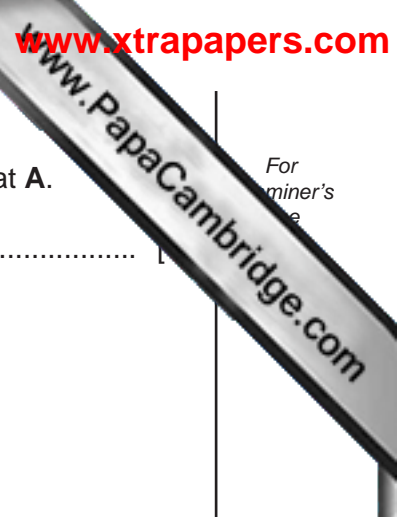

Fig. 13

- (a) (i) Name a hardwood commonly used in the manufacture of children's toys.  
..... [1]
- (ii) State **one** property of hardwood that makes it suitable.  
..... [1]



For  
miner's  
e

(b) Name and sketch **two** constructions that could be used to join the sides at A.

Name .....

Sketch

[3]

Name .....

[1]

Sketch

[3]

(c) The handle must be capable of height adjustment and removal.

Use sketches and notes to complete the design of the handle to show how it can be:

- fitted to the sides of the truck;
- adjusted and secured at **three** different heights;
- easily removed.

[6]

(d) Use sketches and notes to show how the wheels could be prevented from coming off the axle. Consider the safety of a child using the truck in your method.

[3]



(e) The wheels could be produced on a lathe.

Use sketches and notes to show how **one** wheel could be produced.

Include details of the preparation of the wood used for the wheel before it is set up on the lathe.

For  
miner's  
e

www.PapaCambridge.com

[6]





---

Permission to reproduce items where third-party owned material protected by copyright is included has been sought and cleared where possible. Every reasonable effort has been made by the publisher (UCLES) to trace copyright holders, but if any items requiring clearance have unwittingly been included the publisher will be pleased to make amends at the earliest possible opportunity.

University of Cambridge International Examinations is part of the Cambridge Assessment Group. Cambridge Assessment is the brand name of University of