



**Cambridge International Examinations**  
Cambridge International General Certificate of Secondary Education

CANDIDATE  
NAME

CENTRE  
NUMBER

--	--	--	--	--

CANDIDATE  
NUMBER

--	--	--	--



**DESIGN AND TECHNOLOGY**

**0445/33**

Paper 3 Resistant Materials

**October/November 2014**

**1 hour**

Candidates answer on the Question Paper.

No Additional Materials are required.

**To be taken together with Paper 1 in one session of 2 hours 15 minutes.**

**READ THESE INSTRUCTIONS FIRST**

Write your Centre number, candidate number and name on all the work you hand in.

Write in blue or black pen.

You may use an HB pencil for any diagrams, graphs or rough working.

Do not use staples, paper clips, glue or correction fluid.

**DO NOT WRITE IN ANY BARCODES.**

**Section A**

Answer **all** questions in this section.

**Section B**

Answer **one** question in this section.

You may use a calculator.

The total of the marks for this paper is 50.

The number of marks is given in brackets [ ] at the end of each question or part question.

For Examiner's Use	
<b>Section A</b>	
<b>Section B</b>	
<b>Total</b>	

This document consists of **18** printed pages and **2** blank pages.

**Section A**

Answer **all** questions in this section.

1 Fig. 1 shows three products made from different metals.

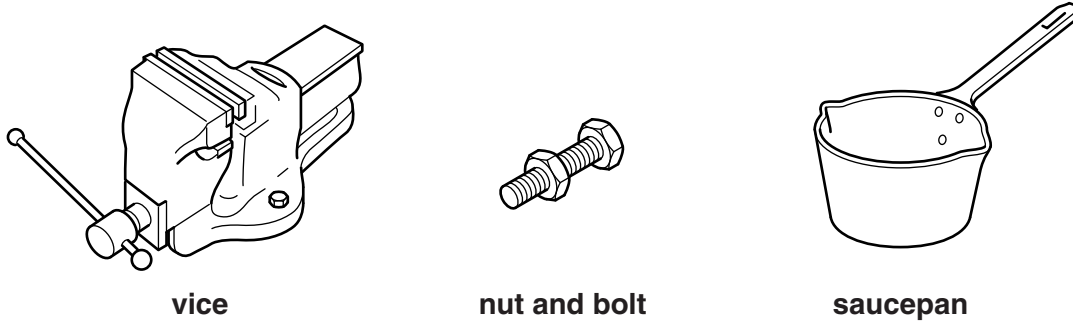

**Fig. 1**

Select a metal from the list below that could be used to make each product.

- aluminium      cast iron      brass      mild steel      lead**

vice .....

nut and bolt .....

saucepan .....[3]

2 Fig. 2 shows a wheel brace and twist drill being used to drill a hole in wood.

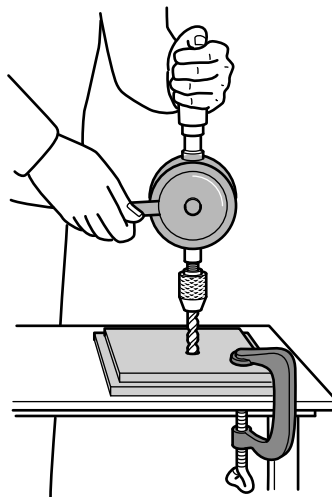

**Fig. 2**

Give **two** reasons why scrap wood is clamped underneath the wood being drilled.

1 .....

2 .....[2]

3 Complete the table below by naming each tool and giving a specific use.

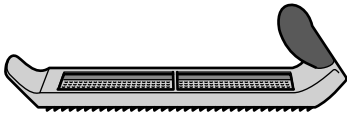
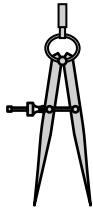
Tool	Name	Specific use
		
		

[4]

4 Complete the drawing below to show a sliding bevel.

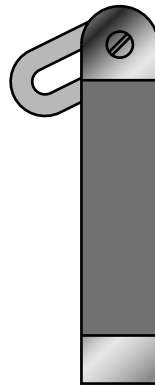

[2]

5 Name the **two** methods of filing shown in Fig. 3.

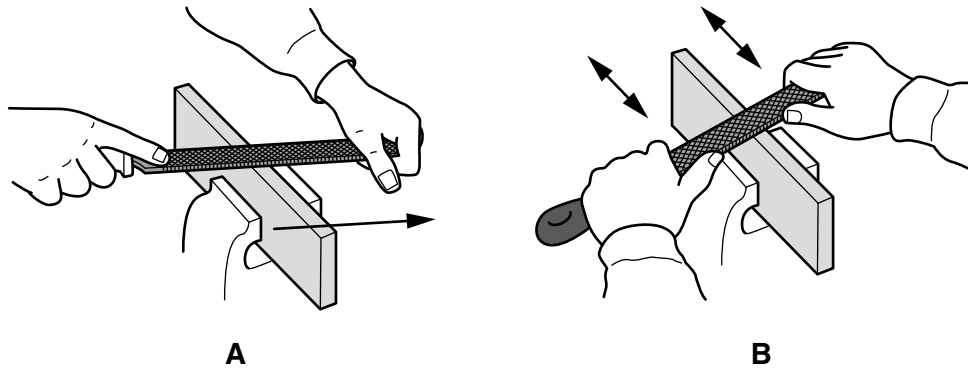

Fig. 3

A .....

B ..... [2]

6 Fig. 4 shows a cross-pein hammer.

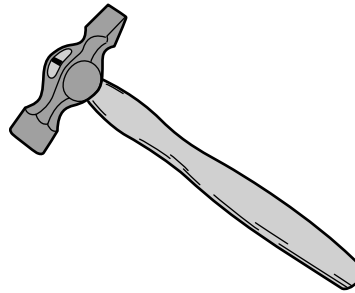

Fig. 4

(a) The hammer handle is made from ash.

State **one** property of ash that makes it suitable for the hammer handle.

.....[1]

(b) Give **one** reason why one end of the hammer head is wedge shaped.

.....[1]

7 Fig. 5 shows a cycle helmet.

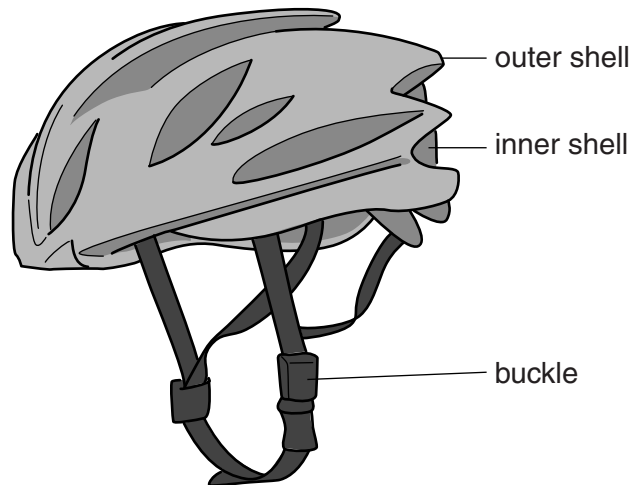

Fig. 5

Name a specific plastic used to make the:

(a) outer shell;

.....[1]

(b) inner shell;

.....[1]

(c) buckle.

.....[1]

8 Fig. 6 shows a board made from solid wood.

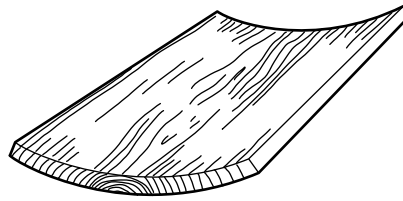

Fig. 6

(a) Name the fault that has occurred in the board.

.....[1]

(b) Give **one** reason why the fault has occurred.

.....[1]

9 Fig. 7 shows part of a table top and a rail.

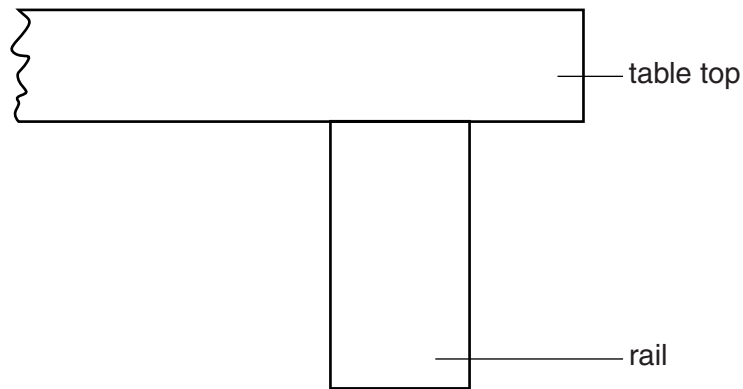

Fig. 7

(a) Complete Fig. 7 to show how the rail could be fixed to the top using a screw. [2]

(b) Give **one** benefit of using screws when constructing products made from wood.

.....[1]

10 Fig. 8 shows sheet metal being cut.

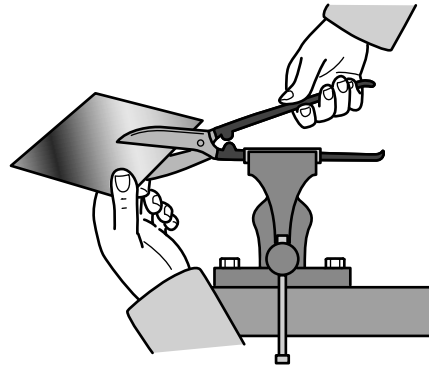

Fig. 8

(a) Name the tool used to cut the sheet metal.

.....[1]

(b) Give **one** benefit of holding the tool in the vice while cutting the sheet metal.

.....[1]

**Section B**

Answer **one** question from this section.

- 11** Fig. 9 shows a play table for children.  
The play table is made from 18 mm thick MDF and supplied as flat-pack for self-assembly.

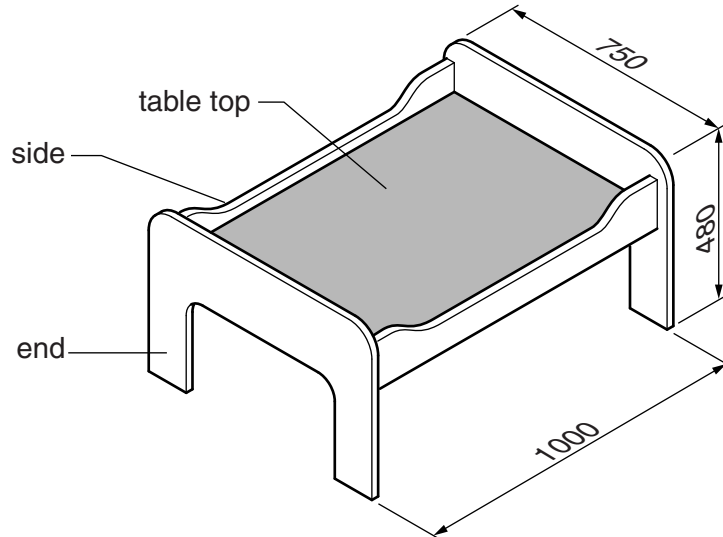

**Fig. 9**

- (a)** Describe **two** features of the design of the play table that make it suitable for children 3-6 years of age.

1 .....

2 .....[2]

- (b) (i)** Give **two** benefits of using a template to mark out the shapes of the sides and ends.

1 .....

2 .....[2]

- (ii)** Name **one** electrically powered saw that could be used to cut out the shapes of the sides and ends.

.....[1]

(c) (i) Give **two** benefits of using MDF for the play table.

1 .....

2 ..... [2]

(ii) The sides and the ends of the play table will be finished by spray painting.  
Give **two** advantages of spray painting rather than applying the paint with a brush.

1 .....

2 ..... [2]

(d) The table top will be covered with a plastic laminate.

(i) Give **one** reason for covering the table top with a plastic laminate.

..... [1]

(ii) Name a suitable adhesive that could be used to glue a plastic laminate to the table top.

..... [1]

(e) Use sketches and notes to show how one end and one side could be joined using KD (knock-down) fittings.

[3]



- (f) Use sketches and notes to show how the table top could be supported inside the sides and ends. Your method must allow for removal.

[3]

- (g) Use sketches and notes to show a modification to the play table so that it could be lifted easily.  
Include details describing how the modification would be carried out in a school workshop.

[3]

10

- (h) The play table could be made using legs and rails made from solid wood. Use sketches and notes to show how the play table could be made from solid wood. Show the sizes of the legs and rails on your sketches.

[5]

12 Fig. 10 shows a workstation for a laptop computer. The workstation is made from 16mm thick melamine faced chipboard and will be wall-mounted.

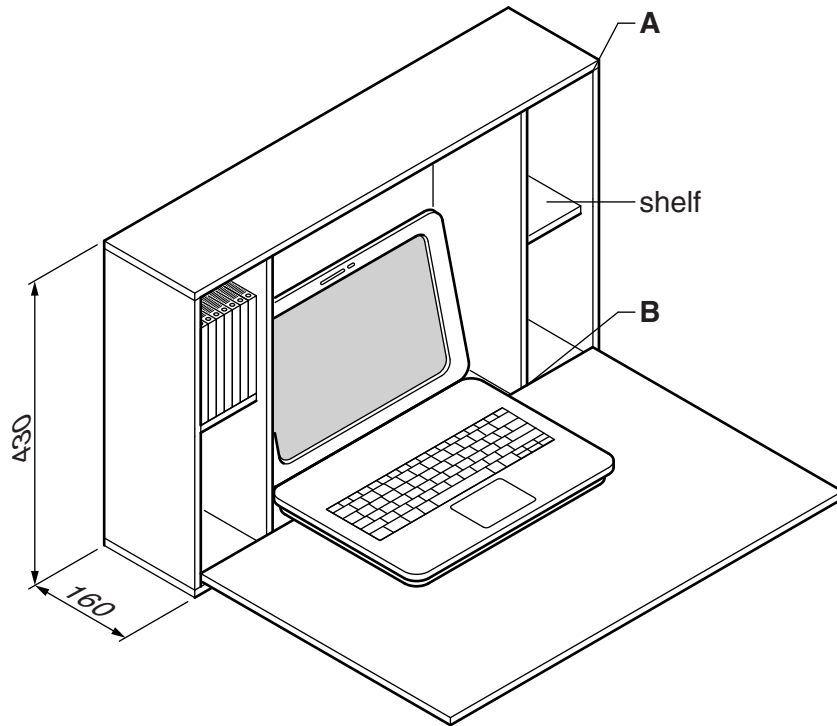

Fig. 10

(a) Give **one** advantage and **one** disadvantage of using melamine faced chipboard for the workstation.

Advantage .....

Disadvantage .....[2]

(b) Sketch and name a corner joint at **A**.

Name of joint .....[4]

(c) (i) Name **two** marking out tools, other than a pencil and rule, that could be used to mark out the joint named in (b).

1 .....

2 .....[2]

(ii) Give the specific names of **two** other tools that could be used to produce the joint named in (b).

1 .....

2 .....[2]

(d) Sketch and name a permanent joint that could be used to join the upright partition to the base at **B**.

Name of joint ..... [4]

(e) Use sketches and notes to show how each shelf could be adjusted to three different heights.

[3]

- (f) The workstation has a 4 mm thick plywood back.  
Use sketches and notes to show how the back of the workstation could be strengthened so that it could be screwed to a wall.

[3]

- (g) The design of the workstation could involve the use of a variety of pre-manufactured fittings.
  - (i) Describe how **three** different pre-manufactured fittings could be used in the construction of the workstation.

- 1 .....
- 2 .....
- 3 ..... [3]

- (ii) Give **two** advantages of using pre-manufactured fittings.

- 1 .....
- 2 ..... [2]

13 Fig. 11 shows an incomplete design for a desk tidy made from acrylic. The base is not shown.

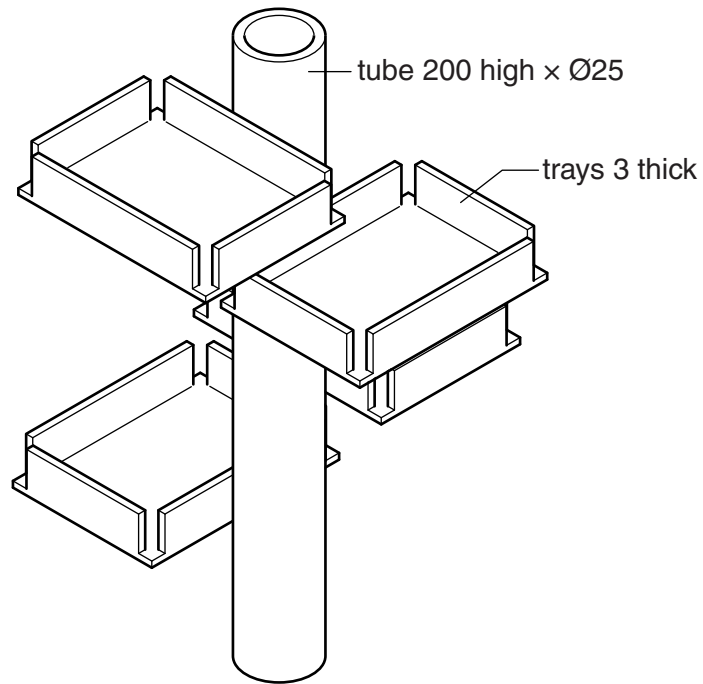

Fig. 11

(a) Give **two** benefits of making the desk tidy from acrylic.

1 .....

2 .....[2]

15

(b) Fig. 12 shows details of one tray marked out on acrylic sheet.

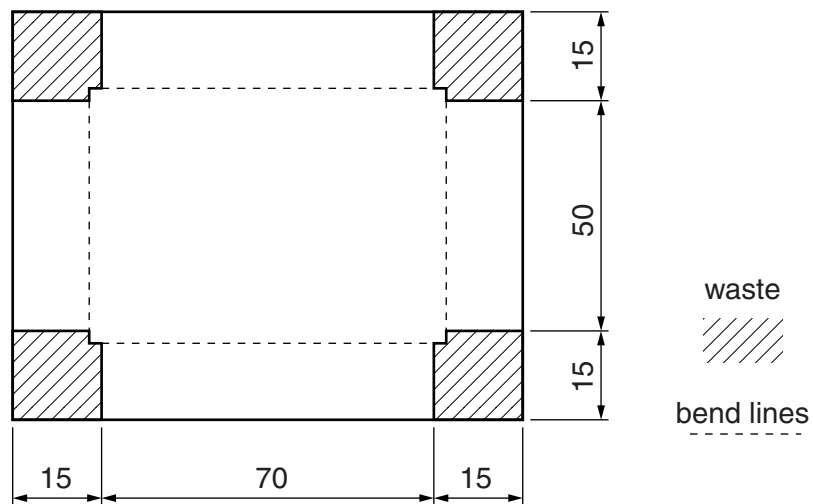

**Fig. 12**

- (i) Use sketches and notes to show how the tray could be cut out and the edges made flat and smooth. Show how the acrylic would be held securely during the process.

[4]

(ii) Use sketches and notes to show how the sides of the tray could be bent to shape. Include the following details:

- the method of heating the acrylic;
- use of a former;
- the method of holding the acrylic while it cools.

[5]



- (c) Fig. 13 shows a cross-sectional view of an extrusion machine used to produce the tube for the desk tidy.

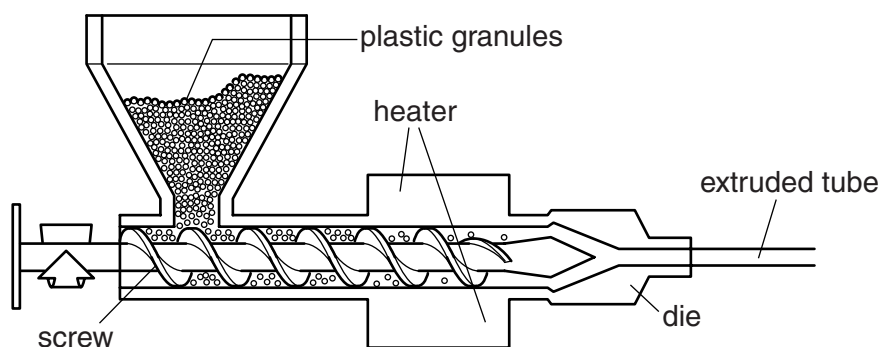

Fig. 13

Complete the table to show the stages in producing the extruded tube.

Stage	Process
1	
2	
3	
4	The extruded tube cools.

[3]

- (d) Use sketches and notes to show how **one** of the trays could be attached to the tube. Your method must allow the tray to be removed quickly and must include fittings made only from acrylic.

[5]

- (e) (i) Use sketches and notes to show a design for a base into which the tube will fit permanently. Include details of sizes and construction.

[4]

- (ii) Use sketches and notes to show how you would check that the tube is upright when fitted to the base.

[2]



**BLANK PAGE**

---

Permission to reproduce items where third-party owned material protected by copyright is included has been sought and cleared where possible. Every reasonable effort has been made by the publisher (UCLES) to trace copyright holders, but if any items requiring clearance have unwittingly been included, the publisher will be pleased to make amends at the earliest possible opportunity.

Cambridge International Examinations is part of the Cambridge Assessment Group. Cambridge Assessment is the brand name of University of Cambridge Local Examinations Syndicate (UCLES), which is itself a department of the University of Cambridge.