



**Cambridge International Examinations**  
Cambridge International General Certificate of Secondary Education

CANDIDATE  
NAME

CENTRE  
NUMBER

--	--	--	--	--

CANDIDATE  
NUMBER

--	--	--	--



**DESIGN AND TECHNOLOGY**

**0445/43**

Paper 4 Systems and Control

**October/November 2014**

**1 hour**

Candidates answer on the Question Paper.

No Additional Materials are required.

**To be taken together with Paper 1 in one session of 2 hours and 15 minutes.**

**READ THESE INSTRUCTIONS FIRST**

Write your Centre number, candidate number and name on all the work you hand in.

Write in dark blue or black pen.

You may use an HB pencil for any diagrams, graphs or rough working.

Do not use staples, paper clips, glue or correction fluid.

**DO NOT WRITE IN ANY BARCODES.**

**Section A**

Answer **all** questions in this section.

**Section B**

Answer **one** question in this section.

You may use a calculator.

The total of the marks for this paper is 50.

The number of marks is given in brackets [ ] at the end of each question or part question.

For Examiner's Use	
Section A	
Section B	
<b>Total</b>	

This document consists of **17** printed pages and **3** blank pages.

**Section A**

Answer **all** questions in this section.

- 1 (a) Fig. 1 shows a small pulley system that can be used for lifting heavy pieces of machinery.

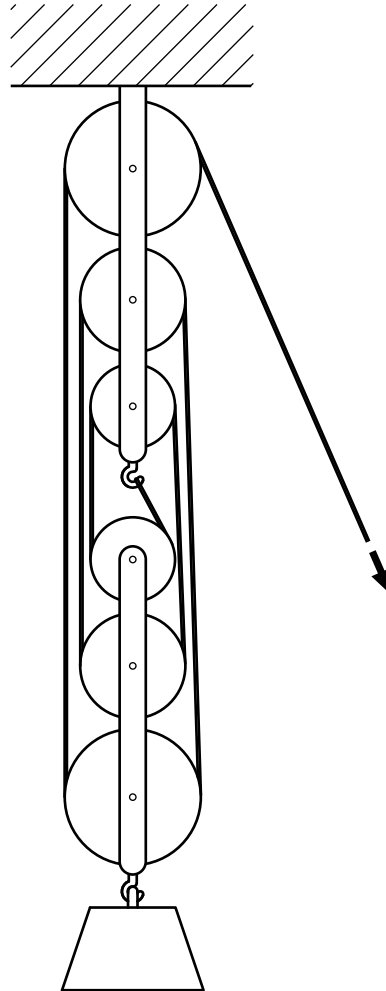

**Fig. 1**

Give **two** effects of using a pulley system.

- 1 .....
- 2 ..... [2]

- (b) (i) State how the mechanical advantage gained from using the pulley system can be determined.

..... [1]

- (ii) State the mechanical advantage in the system shown in Fig. 1.

..... [1]

3

2 (a) Pneumatic tools are often used for production work.  
Give **two** benefits of using compressed air to power tools.

1 .....

.....

2 .....

.....

[2]

(b) Name **one** tool that can be powered by compressed air.

.....[1]

3 Fig. 2 shows two shafts at 90° to each other.

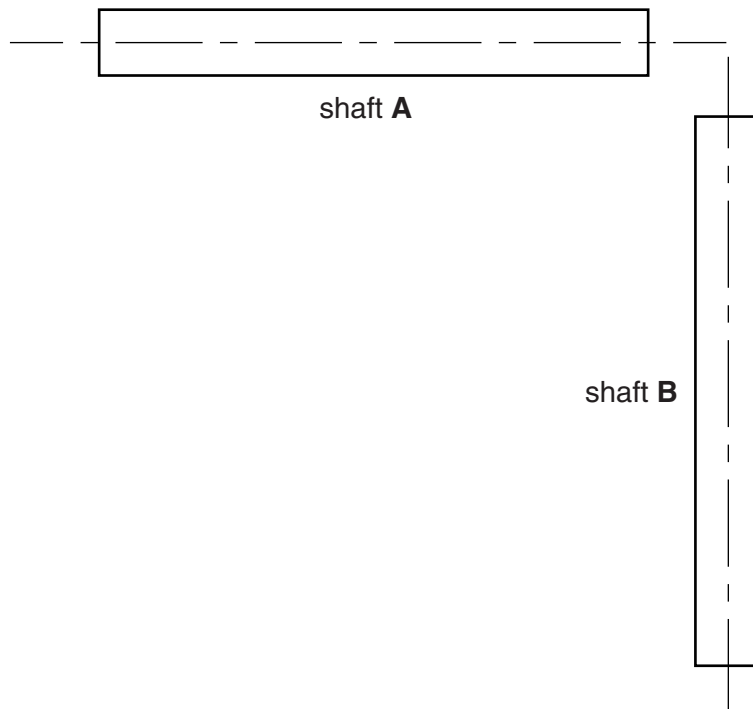

Fig. 2

Draw on Fig. 2 to show a method of transmitting drive from shaft A to shaft B with no change in speed. [3]

- 4 Fig. 3 shows an LED lamp that plugs into a computer USB socket. The printed circuit layout with LEDs and resistors in position is also shown.

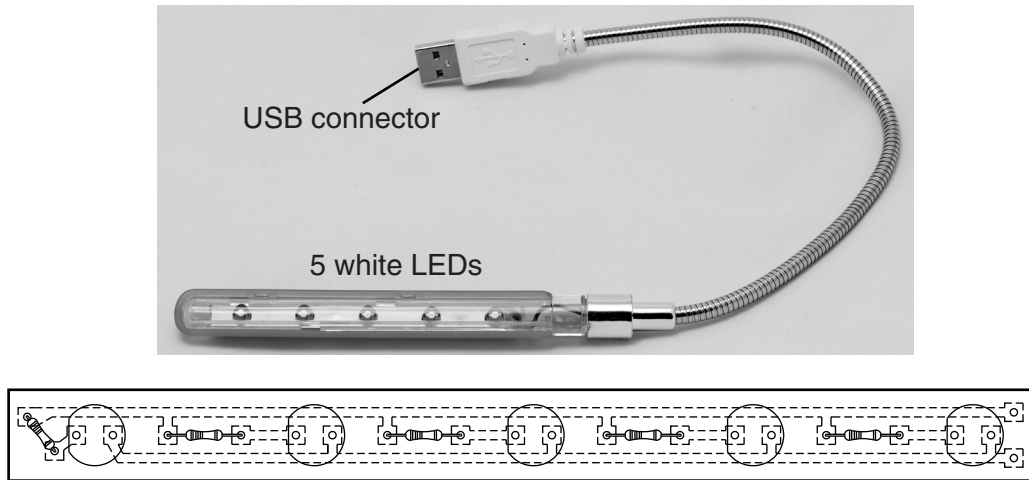

Fig. 3

- (a) The LEDs have been connected to the circuit in parallel. Give **one** reason for using this method of connection.

.....[1]

- (b) Each LED must be inserted correctly into the circuit. Describe **two** methods that can be used to identify the cathode on an LED.

1 .....

2 .....

[2]

- 5 Use sketches and notes to describe the procedure for fitting and soldering an LED into a circuit board.

[4]

6 Modern car bodies use shell structures with no framework or chassis.

(a) Explain how sheet materials used for car bodies can be strengthened.

.....  
 .....  
 ..... [2]

(b) Some parts of a car body known as crumple zones are designed to deform on impact. Give **one** reason for crumple zones being used in a car body.

..... [1]

7 Describe how stress in a structural material can be calculated.

.....  
 .....  
 ..... [2]

8 Fig. 4 shows a footbridge suspended from a tubular steel column.



**Fig. 4**

An adjuster for one of the steel suspension wires is shown on the left. Describe how turning the adjuster alters the height of the bridge.

.....  
 .....  
 ..... [3]

**Section B**

Answer **one** question from this section.

- 9 (a) (i) Give the meaning of the term *moment* in structures.

.....  
 ..... [2]

- (ii) Fig. 5 shows a roof truss resting on two walls.

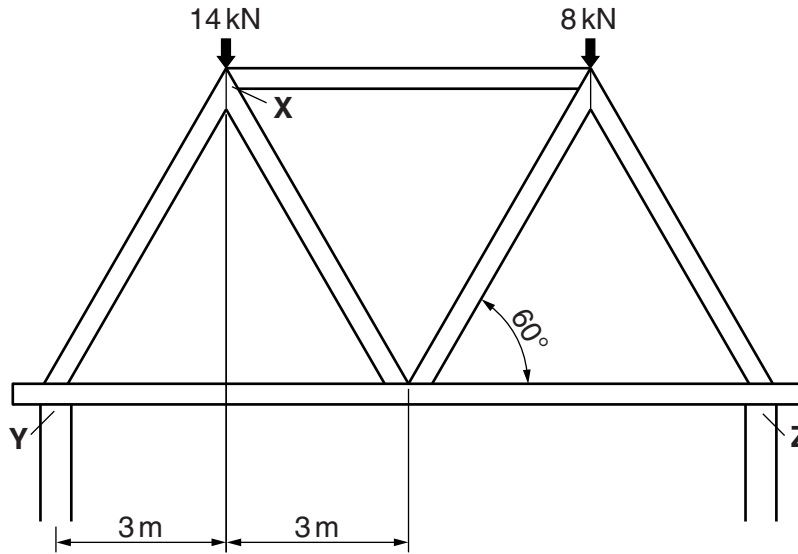

**Fig. 5**

Use the principle of moments to complete the calculation of the values of reactions at **Y** and **Z**,  $R_Y$  and  $R_Z$ .

Taking moments about **Y**:  $R_Z \times 12 = (14 \times 3) + (8 \times 9)$

.....  
 .....  
 ..... [4]

- (iii) Fig. 6 shows an enlarged view of the roof truss joint at **X**.

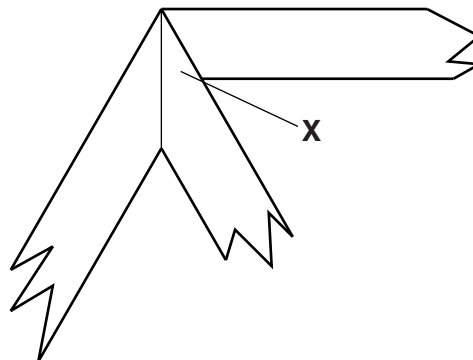

**Fig. 6**

Draw a gusset plate at point **X** on Fig. 6 and show how it will be fixed in position. [3]

(b) Concrete is commonly used as a structural material in building construction.

(i) Give **two** advantages of using concrete rather than bricks for large buildings.

1 .....

2 .....

[2]

(ii) Explain how the tensile strength of concrete can be increased.

.....

.....[2]

(iii) Fig. 7 shows a concrete beam and a steel box section, both could be placed above an opening in a wall.

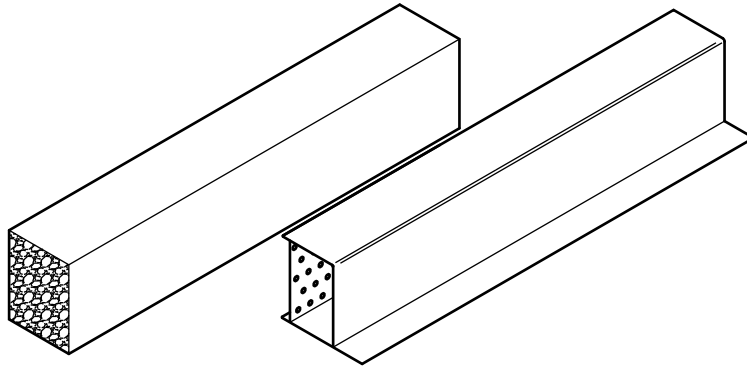

Fig. 7

Give **two** reasons for using a steel box section rather than a concrete beam.

1 .....

.....

2 .....

.....

[2]

- (c) Fig. 8 shows part of a bird feeding platform that is to be made as a free-standing structure with a single central support. The support is shown resting on the ground.

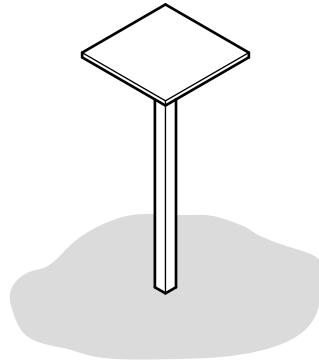

Fig. 8

- (i) Use sketches and notes to show a suitable structure for the base of the central support. Include details of materials and constructions used.

[4]

- (ii) The structure must remain in equilibrium during use.

Describe what is meant by *equilibrium* in a structure.

.....  
.....[2]



(d) Fig. 9 shows a hardwood drawer constructed in a traditional way using dovetail joints and a modern drawer constructed from hollow PVC sections.



drawer made using dovetail construction



drawer made using glued joints on hollow PVC section

Fig. 9

(i) Explain why traditional methods of joining wood are not often used on modern furniture.

.....  
.....  
.....[2]

(ii) Give **two** benefits of using manufactured board when constructing furniture.

1 .....  
2 ..... [2]

10 (a) Fig. 10 shows three examples of tools that use a ratchet and pawl mechanism.



Fig. 10

- (i) Give **one** reason for using a ratchet and pawl mechanism in the tools shown.  
 .....[1]
- (ii) Give the conversion of motion that takes place when the ratchet and pawl mechanism is in use.  
 input motion .....  
 output motion ..... [2]
- (iii) Explain why the tools in Fig. 10 need a method of reversing the ratchet action.  
 .....  
 .....  
 ..... [2]
- (iv) State which of the tools in Fig. 10 gives the least mechanical advantage to the user.  
 ..... [1]

(b) A cam and lever follower which are part of a mechanical toy are shown in Fig. 11.

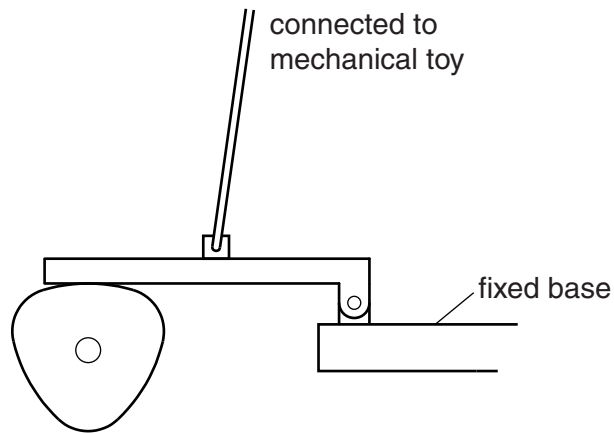

Fig. 11

(i) Describe the action of the follower for one rotation of the camshaft.

.....  
 ..... [2]

(ii) State the order of lever used in the follower.

..... [1]

(iii) Label Fig. 11 to show the position of the load, effort and fulcrum on the lever follower. [3]

(iv) Fig. 12 shows the cam outline from Fig. 11. Use notes and sketches to show a modified lever follower that will provide more movement.

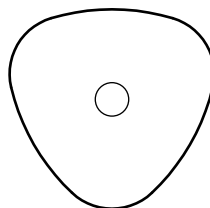

Fig. 12

[3]

(c) A small bench pillar drill is shown in Fig. 13.

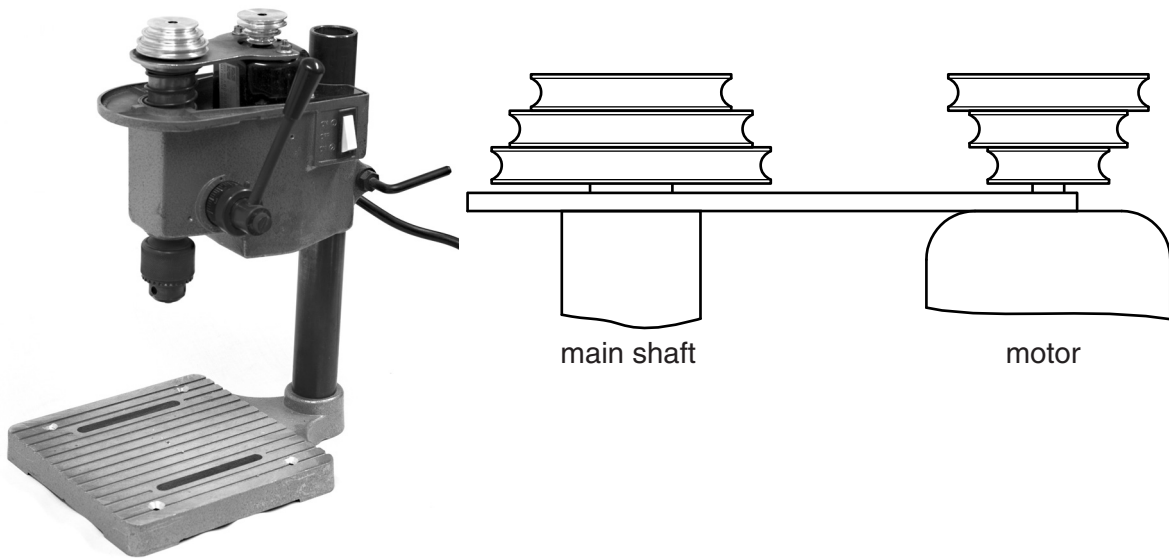
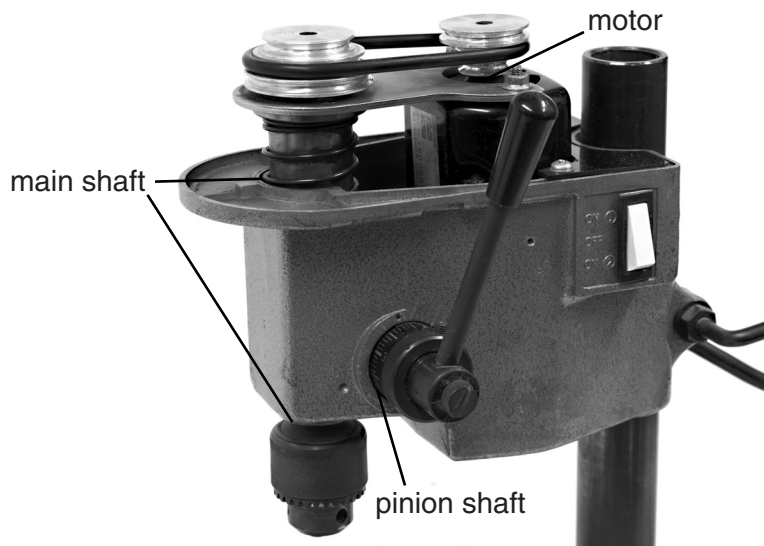

Fig. 13

(i) Draw the belt in the position that will give the fastest drilling speed. [1]

(ii) Fig. 14 identifies three areas of the drill unit that will require bearings. Complete the table by choosing from the list below to show the most suitable type of bearing for each shaft.



- bronze plain bearing    steel plain bearing
  - ball bearings    roller bearings
- bearing type

main shaft	
motor shaft	
pinion shaft	

Fig. 14

[3]

(iii) Most bearings require lubrication. Give **two** reasons why lubrication of bearings is necessary.

- 1 .....
- 2 .....

[2]

(iv) Name a bearing material that does not require lubrication.

.....[1]

(d) Fig. 15 shows a pulley fitted to a shaft.

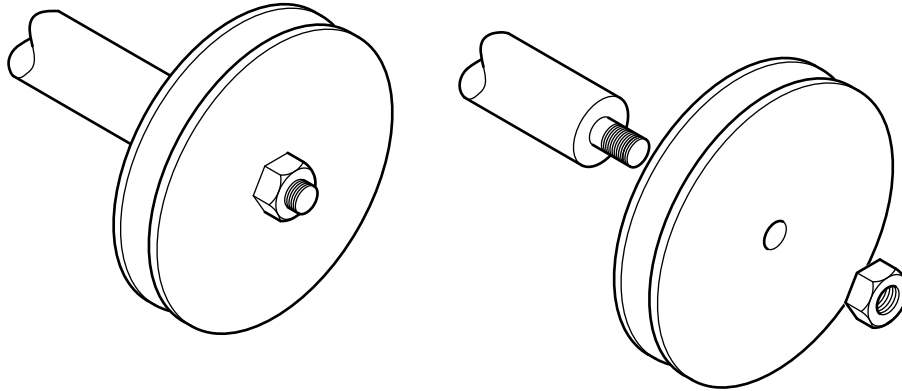

**Fig. 15**

Use notes and sketches to show how the pulley and shaft assembly can be modified:

- to prevent the pulley from slipping on the shaft;
- to prevent the nut from coming loose during use.

[3]

- 11 (a) An external door lock is to be remotely operated using a light-sensitive switch to provide a signal that will unlock the door.

Fig. 16 shows a light-sensitive switch circuit which operates when light is blocked from an LDR sensor by placing a finger over the sensor.

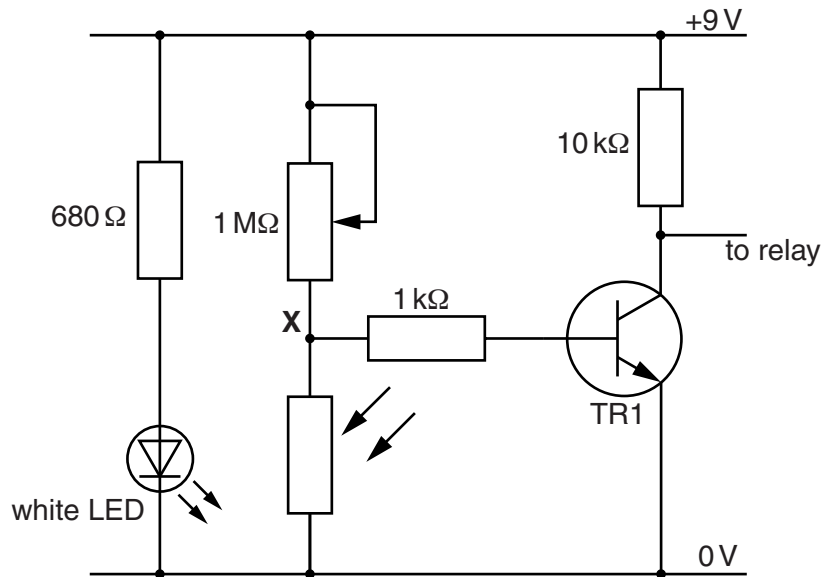

Fig. 16

- (i) Explain why a white LED light source is used in the switch rather than natural light.

.....  
 ..... [2]

- (ii) State the voltage that can be expected at point X when TR1 switches on.

..... [1]

- (iii) Describe how the 1 MΩ potentiometer is used to set up the switch for use.

.....  
 .....  
 ..... [3]

- (iv) Use notes and sketches to show a simple casing design to hold the LED light source and the LDR in position on a wall.  
The casing should allow a finger to be placed between the two components to operate the switch.

[4]

- (b) The signal from the light-sensitive switch operates a relay (RLA1) with a solenoid (S1) connected to the output terminals.  
Fig. 17 shows the relay and solenoid circuit.

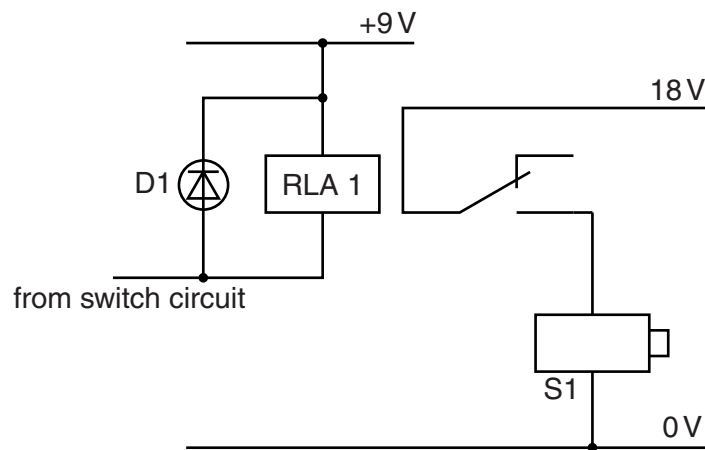

Fig. 17

- (i) The solenoid lock and the switch circuit operate at different voltages.  
Explain how the two voltages are isolated from each other.

.....  
 .....  
 .....[2]

- (ii) Describe the type of movement provided by a solenoid.

.....[1]

(iii) Fig. 18 shows the solenoid resistance being tested with a multimeter.

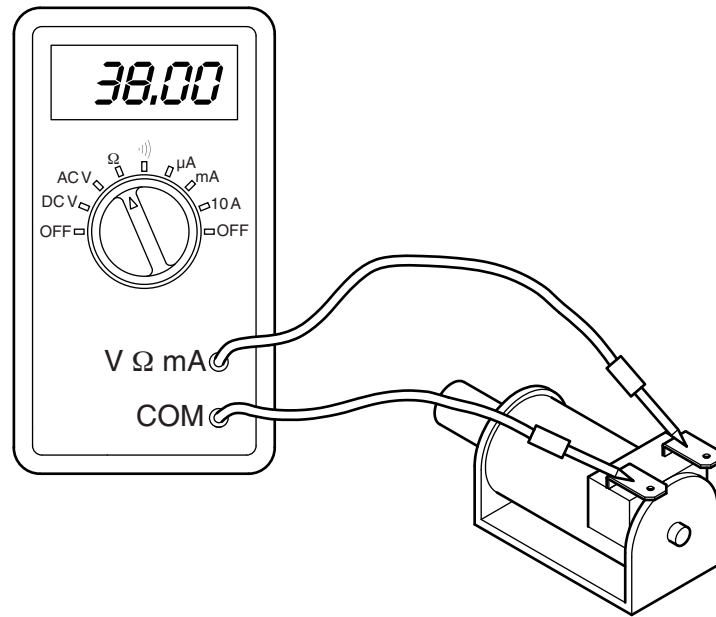

Fig. 18

Calculate the current that will flow in the circuit when the solenoid is connected to an 18V supply. Use the formula  $I = V / R$ .

.....

.....

.....[3]

(c) To control the time that the solenoid lock is held open a monostable time delay is used. This will keep the solenoid switched on for 3 seconds. The monostable circuit and IC are shown in Fig. 19.

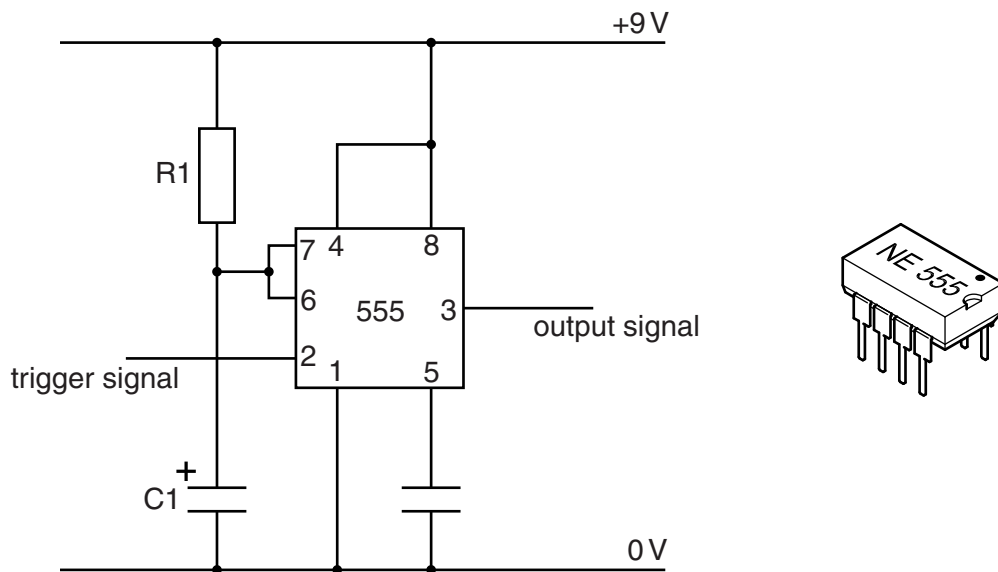

Fig. 19



- (i) The 555 timer IC is manufactured in an 8 pin dil package.  
Describe how the user of the package can identify pin 1 of the IC.

.....  
.....[2]

- (ii) When the trigger pin (2) goes from high to low, the output pin (3) goes high for 3 seconds.  
Complete the graph below to show the output signal.

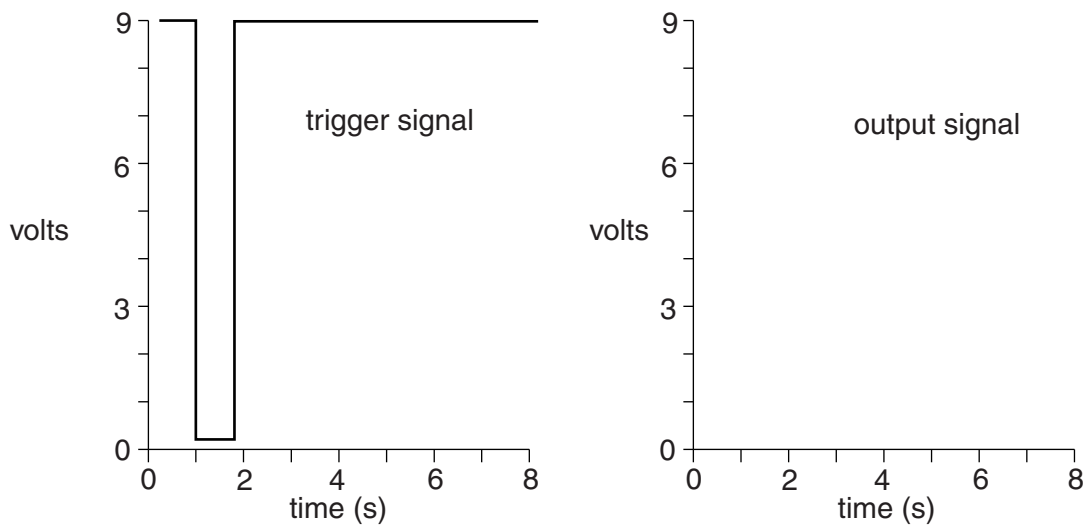

[2]

- (iii) Describe what will happen if the trigger pin remains low for longer than 3 seconds.

.....  
.....  
.....[2]

- (d) The delay can be altered by using a rotary switch to connect different resistors to the circuit.  
Fig. 20 shows a rotary switch.  
Use notes and sketches to explain how a rotary switch works.

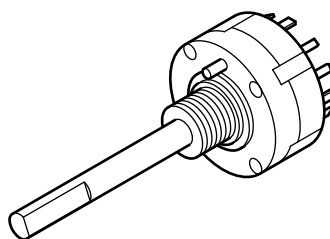

Fig. 20

[3]





**BLANK PAGE**

---

Permission to reproduce items where third-party owned material protected by copyright is included has been sought and cleared where possible. Every reasonable effort has been made by the publisher (UCLES) to trace copyright holders, but if any items requiring clearance have unwittingly been included, the publisher will be pleased to make amends at the earliest possible opportunity.

Cambridge International Examinations is part of the Cambridge Assessment Group. Cambridge Assessment is the brand name of University of Cambridge Local Examinations Syndicate (UCLES), which is itself a department of the University of Cambridge.