



UNIVERSITY OF CAMBRIDGE INTERNATIONAL EXAMINATIONS
International General Certificate of Secondary Education

CANDIDATE
NAME

CENTER
NUMBER

--	--	--	--	--

CANDIDATE
NUMBER

--	--	--	--

* 2 9 2 2 1 8 6 6 0 7 *

MATHEMATICS (US)

0444/33

Paper 3 (Core)

October/November 2013

2 hours

Candidates answer on the Question Paper.

Additional Materials: Geometrical instruments
Electronic calculator

READ THESE INSTRUCTIONS FIRST

Write your Center number, candidate number and name on all the work you hand in.
Write in dark blue or black pen.
You may use a pencil for any diagrams or graphs.
Do not use staples, paper clips, highlighters, glue or correction fluid.
DO NOT WRITE IN ANY BARCODES.

Answer **all** questions.
If work is needed for any question it must be shown in the space provided.
Electronic calculators should be used.
If the degree of accuracy is not specified in the question, and if the answer is not exact, give the answer to three significant digits.
Give answers in degrees to one decimal place.
For π , use either your calculator value or 3.142.

The number of points is given in parentheses [] at the end of each question or part question.
The total of the points for this paper is 104.

Write your calculator model in the box below.

This document consists of **19** printed pages and **1** blank page.



Formula List

Area, A , of triangle, base b , height h .

$$A = \frac{1}{2}bh$$

Area, A , of circle, radius r .

$$A = \pi r^2$$

Circumference, C , of circle, radius r .

$$C = 2\pi r$$

Lateral surface area, A , of cylinder of radius r , height h .

$$A = 2\pi rh$$

Surface area, A , of sphere of radius r .

$$A = 4\pi r^2$$

Volume, V , of prism, cross-sectional area A , length l .

$$V = Al$$

Volume, V , of cylinder of radius r , height h .

$$V = \pi r^2 h$$

Volume, V , of sphere of radius r .

$$V = \frac{4}{3}\pi r^3$$

- 1 (a) A regular polygon has 9 sides.
For this polygon, calculate
- (i) the size of one exterior angle,

Answer(a)(i) [2]

- (ii) the size of one interior angle.

Answer(a)(ii) [1]

(b)

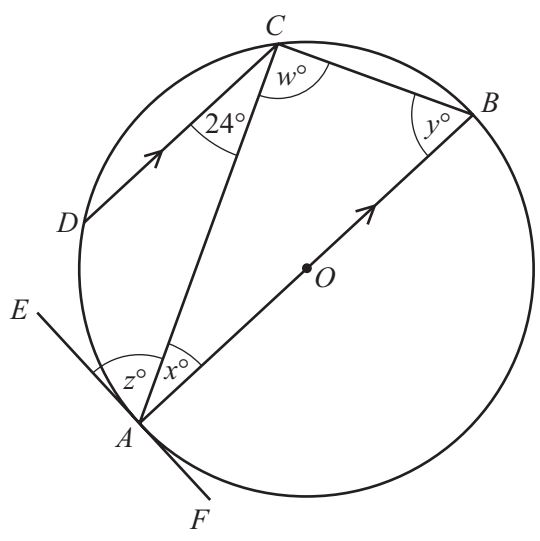

NOT TO SCALE

In the diagram, A, B, C and D are points on the circumference of a circle, center O .
 AB is the diameter and EF is a tangent to the circle at A .
 AB is parallel to DC and angle $ACD = 24^\circ$.

Find

- (i) w ,

Answer(b)(i) $w =$ [1]

- (ii) x ,

Answer(b)(ii) $x =$ [1]

- (iii) y .

Answer(b)(iii) $y =$ [1]

(c) Complete the statement.

$z =$ because

..... [2]

2 Adam owns a farm.

- (a) He plans to keep twenty hens.
He works out what he thinks this will cost.

Complete the following table.

Item	Cost (\$)
Equipment	500
20 hens costing \$12 each	
3 years supply of feed costing \$25 per month	
TOTAL	

[3]

- (b) The equipment actually costs \$600.

The ratio of costs is equipment : hens : feed = 5 : 3 : 9 .

- (i) Show that the total cost is now \$2040.

Answer(b)(i)

[2]

- (ii) Adam actually buys more than 20 hens, each costing \$12.

How many hens does he buy?

Answer(b)(ii) [2]

5

(c) Adam makes \$2920 from selling his hens' eggs.
Calculate his percentage profit on the \$2040.

Answer(c) % [2]

(d) Adam borrows \$1500 for 3 years at a rate of 5.5% per year compound interest.
Calculate the interest he will pay, correct to the nearest cent.

Answer(d) \$ [3]

3 The diagram shows four quadrilaterals drawn on a 1 cm^2 grid.

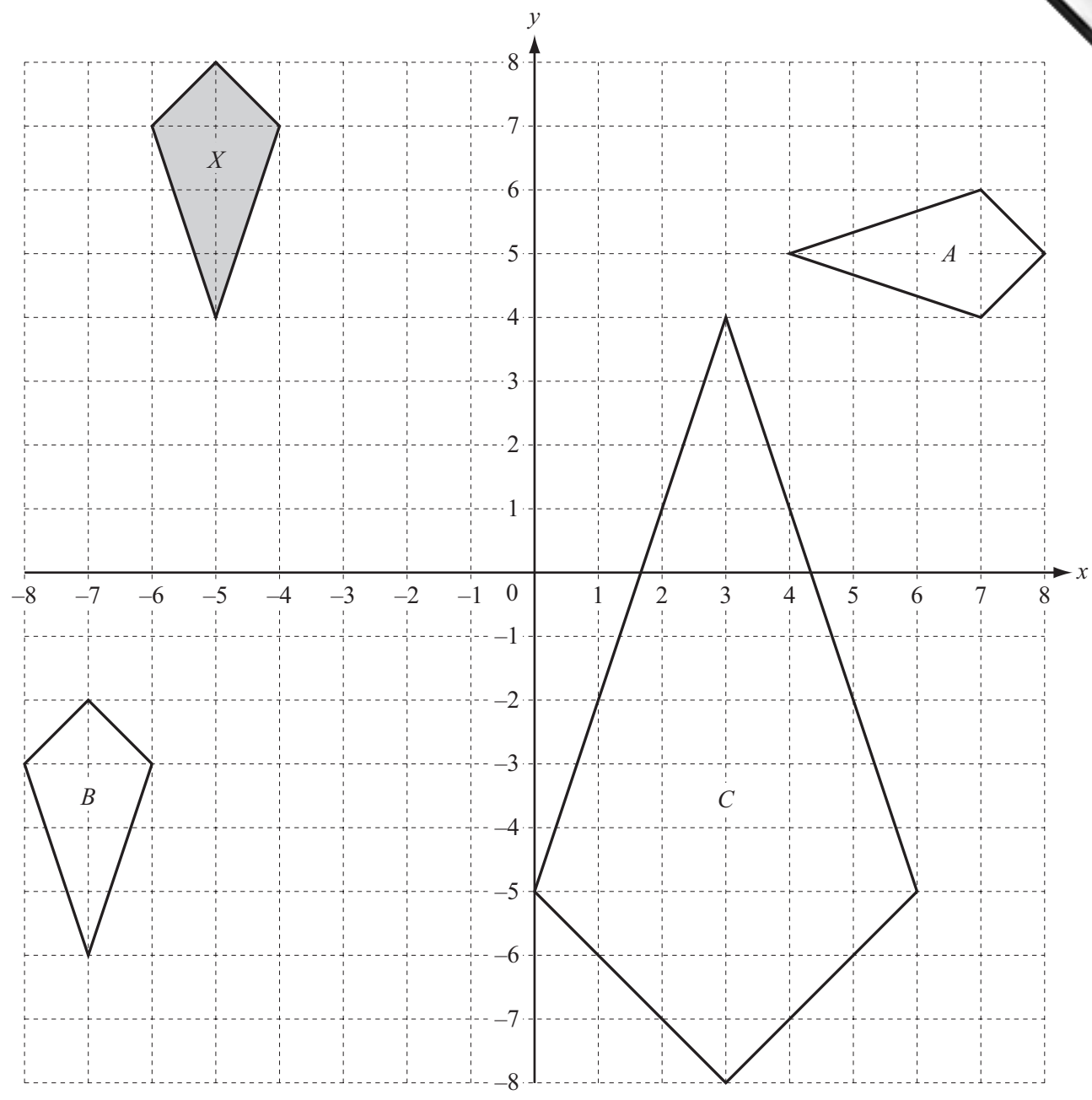

(a) Write down the mathematical name of the quadrilateral X.

Answer(a) [1]

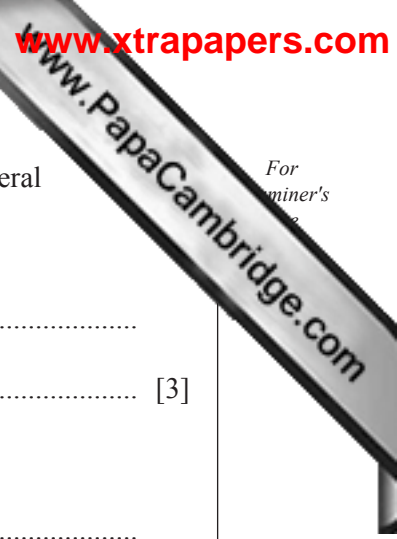

For
aminer's

(b) Describe fully the **single** transformation that maps quadrilateral X onto quadrilateral

(i) A ,

Answer(b)(i)

..... [3]

(ii) B ,

Answer(b)(ii)

..... [2]

(iii) C .

Answer(b)(iii)

..... [3]

(c) (i) Calculate the longest side of quadrilateral X .
Show that your answer rounds to 3.16 cm, correct to 3 significant digits.

Answer(c)(i)

[2]

(ii) Calculate the perimeter of quadrilateral X .

Answer(c)(ii) cm [3]

(iii) Find the perimeter of quadrilateral C .

Answer(c)(iii) cm [1]

4 Loki is playing in a playground.

(a) The diagram shows a ramp in the playground.

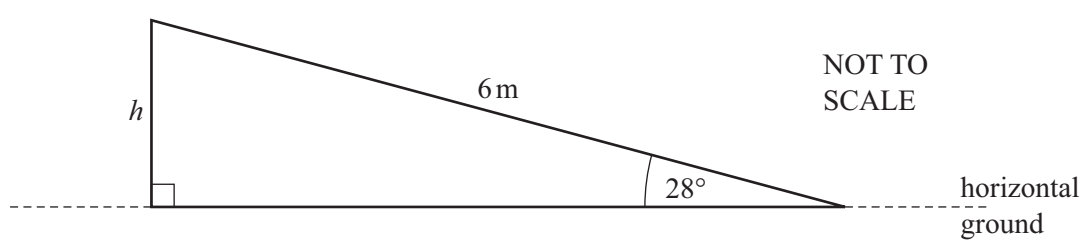

Loki runs up the ramp to the top.

Using trigonometry, calculate h , the height Loki is standing above the horizontal ground.

Answer(a) $h = \dots\dots\dots$ m [2]

(b) The diagram below shows the cross-section of a tunnel in the playground.

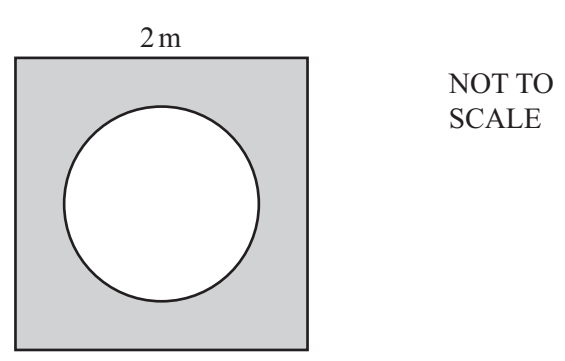

The entrance to the tunnel is a circle of **diameter** 1.5 m cut into a concrete square of side 2 m.

Calculate the area of the concrete, shown shaded, in the cross-section.
State the units of your answer.

Answer(b) $\dots\dots\dots$ [4]

(c)

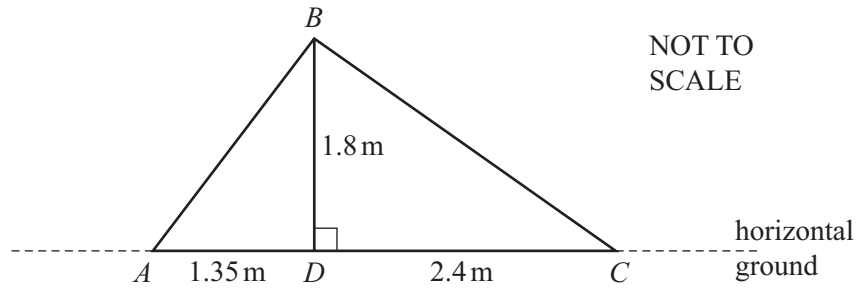

The diagram above shows a side view of the playground slide.
 Loki climbs up the steps from A to B and then slides down from B to C .
 The length of the vertical support, BD , is 1.8 m.
 $AD = 1.35$ m and $DC = 2.4$ m.

(i)

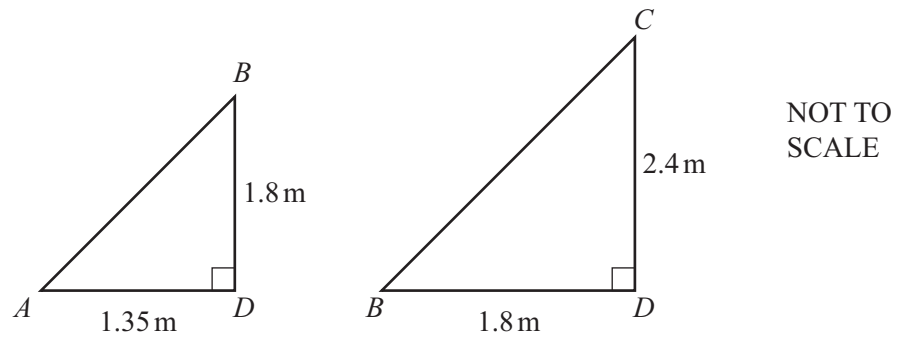

Explain why triangle ABD is **similar** to triangle BCD .

Answer(c)(i)
 [1]

(ii) Write down the scale factor of the enlargement.

Answer(c)(ii) [1]

5 (a) (i) Complete the table for $y = 5 + 3x - x^2$.

x	-2	-1	0	1	2	3	4	5
y	-5		5	7		5		-5

[3]

(ii) On the grid, draw the graph of $y = 5 + 3x - x^2$ for $-2 \leq x \leq 5$.

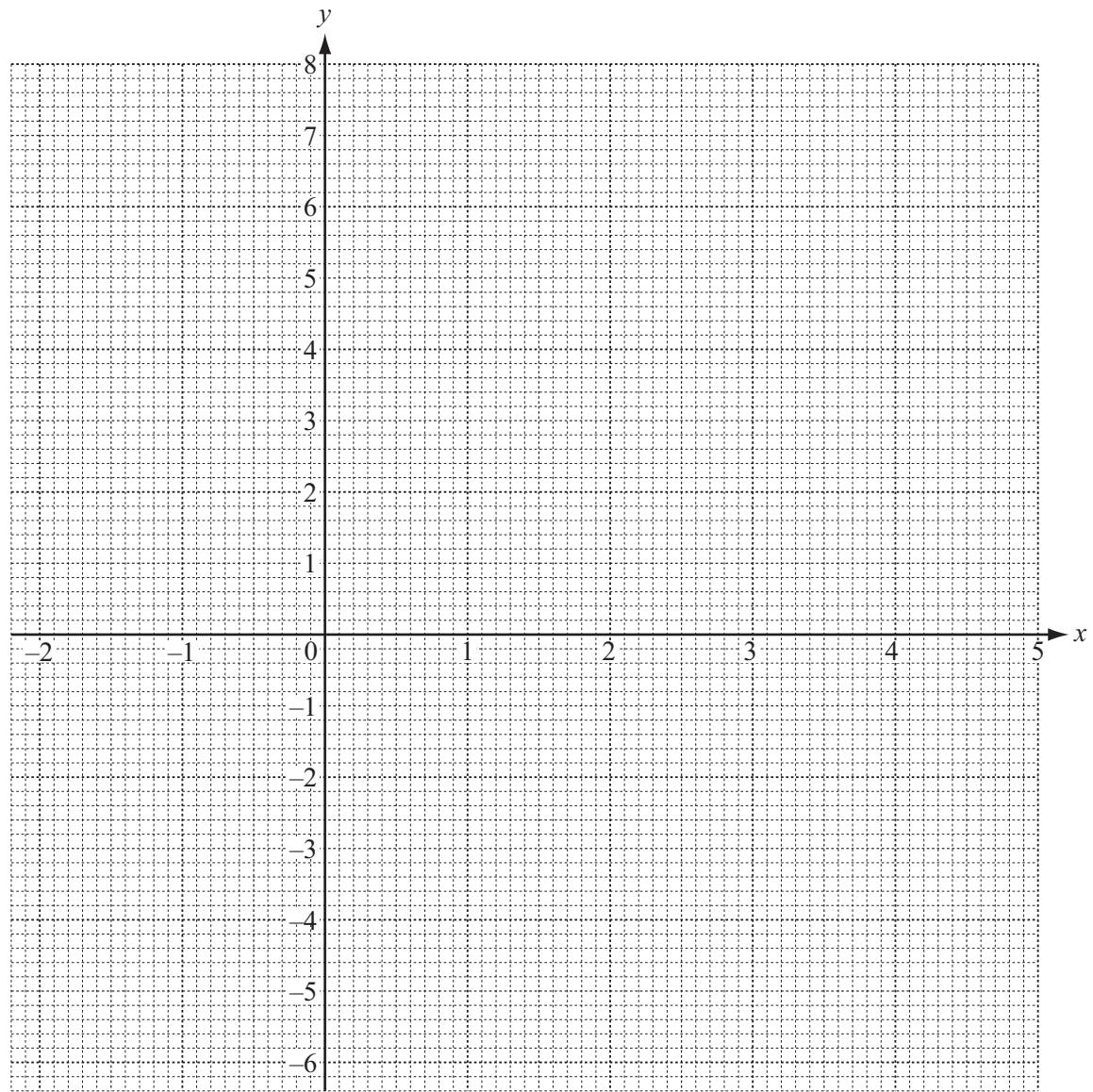

[4]

(b) Use your graph to solve the equation $5 + 3x - x^2 = 0$.

Answer(b) $x = \dots\dots\dots$ or $x = \dots\dots\dots$ [2]

- (c) (i) On the grid, draw the axis of symmetry of $y = 5 + 3x - x^2$.
- (ii) Write down the equation of this axis of symmetry.

Answer(c)(ii) [1]

- (d) (i) On the grid, draw a straight line from $(-1, 1)$ to $(3, 5)$. [1]
- (ii) Work out the slope of this line.

Answer(d)(ii) [2]

- (iii) Write down the equation of this line in the form $y = mx + b$.

Answer(d)(iii) $y =$ [1]

6 Alison scored the following number of runs in 15 cricket matches.

12	3	27	35	0
7	52	4	18	30
18	7	94	61	7

(a) For these scores,

(i) work out the median,

Answer(a)(i) [2]

(ii) write down the mode,

Answer(a)(ii) [1]

(iii) calculate the mean.

Answer(a)(iii) [2]

(b) These are the averages for the number of runs scored by Bethan in the 15 matches.

Median = 21 Mode = 13 Mean = 20

Alison says that her scores are better than Bethan's scores.
Bethan says that her scores are better than Alison's scores.

Explain how they could both be correct.

Answer(b)

.....

..... [2]

(c) Alison puts her 15 scores into 4 groups and shows them in a pie chart.

(i) Complete the table.

Score	Frequency	Sector Angle
0 to 25	9	216°
26 to 50		
51 to 75		
76 to 100		

[3]

(ii) Complete the pie chart and label the sectors.

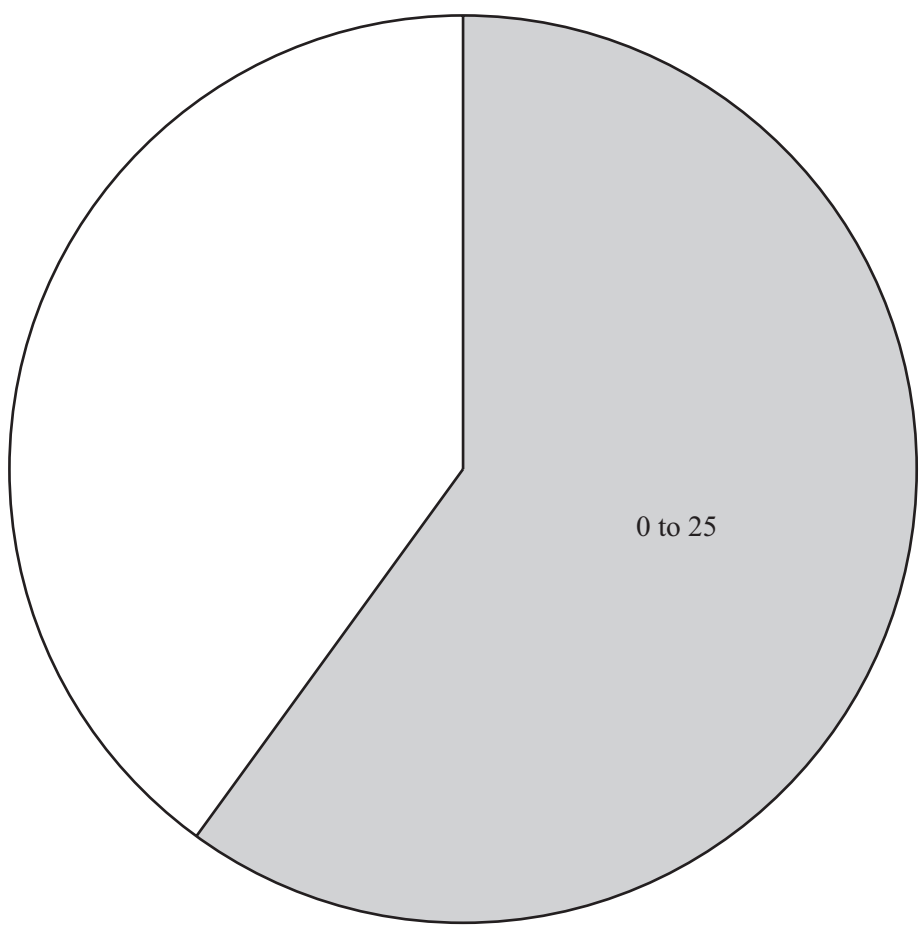

[3]

(d) Find the probability that in the next match Alison will score more than 25 runs. Give your answer as a fraction in simplest form.

Answer(d) [2]

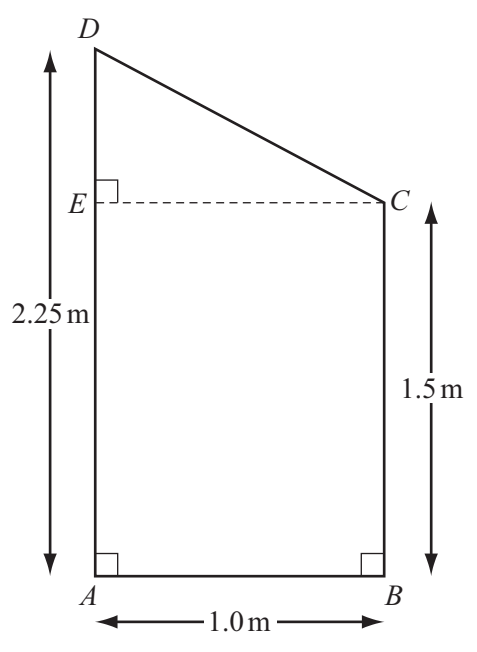

NOT TO SCALE

The diagram shows a trapezoid $ABCD$.
 $AB = 1.0\text{ m}$, $AD = 2.25\text{ m}$, $BC = 1.5\text{ m}$ and angle $DEC = 90^\circ$.

(a) Using trigonometry, calculate angle DCE .

Answer(a) Angle $DCE = \dots\dots\dots$ [3]

(b) Calculate the area of the trapezoid $ABCD$.

Answer(b) $\dots\dots\dots\text{ m}^2$ [2]

(c) $ABCD$ is the cross-section of a box.
 The box is 2 m long.

Calculate the volume of the box.

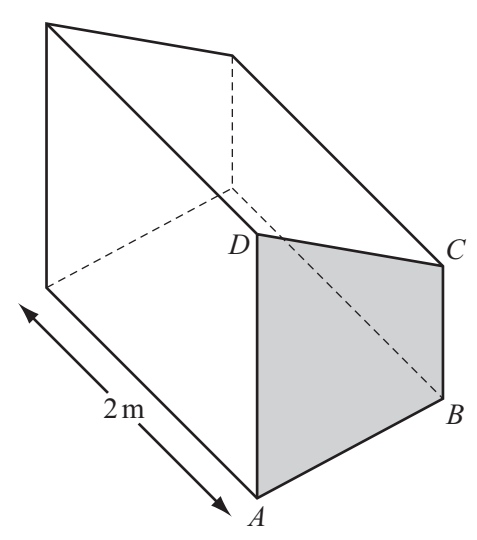

Answer(c) $\dots\dots\dots\text{ m}^3$ [1]

(d) The boxes are manufactured and tested for quality.
The probability that a box is faulty is 0.04 .

(i) Write down the probability that a box is **not** faulty.

Answer(d)(i) [1]

(ii) During one week, 250 boxes are manufactured.

How many of these boxes are expected to be faulty?

Answer(d)(ii) [2]

8 Here is a sequence of patterns made using identical polygons.

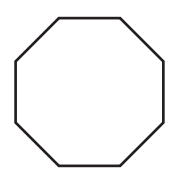

Pattern 1

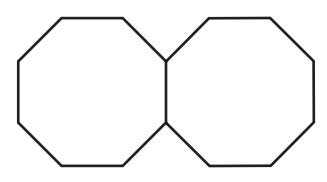

Pattern 2

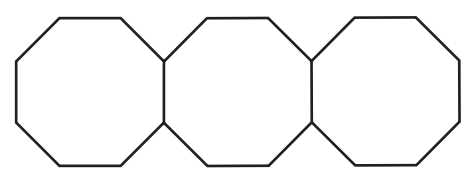

Pattern 3

(a) Write down the mathematical name of the polygon in Pattern 1.

Answer(a) [1]

(b) Complete the table for the number of vertices (corners) and the number of lines in Pattern 3, Pattern 4 and Pattern 7.

Pattern	1	2	3	4		7
Number of vertices	8	14				
Number of lines	8	15				

[5]

(c) (i) Find an expression for the number of **vertices** in Pattern n .

Answer(c)(i) [2]

(ii) Work out the number of vertices in Pattern 23.

Answer(c)(ii) [1]

(d) Find an expression for the number of **lines** in Pattern n .

Answer(d) [2]

(e) Work out an expression, in its simplest form, for

(number of lines in Pattern n) – (number of vertices in Pattern n).

Answer(e) [2]

9 (a) The formula for the volume, V , of a cone with radius r , and height h , is $V = \frac{1}{3}\pi r^2 h$.

(i) To make r the subject of this formula, the first step is $3V = \pi r^2 h$.

Show the remaining steps to solve for r .

Answer(a)(i) $r = \dots\dots\dots$ [2]

(ii) An ice-cream cone has a volume of 141 cm^3 and height 15 cm .

Show that the radius of the cone is 3 cm , correct to the nearest whole number.

Answer(a)(ii)

[2]

(b) The open end of an ice-cream cone is a circle of radius 3 cm .

Calculate the circumference of this circle.

Answer(b) $\dots\dots\dots \text{ cm}$ [2]

19

- (c) The volume of a ball of ice-cream is 113 cm^3 .
The ball of ice-cream costs \$2.15 .

Calculate the cost of 1 cm^3 of the ice-cream.
Give your answer in cents, correct to 1 decimal place.

Answer(c) cents [3]

Permission to reproduce items where third-party owned material protected by copyright is included has been sought and cleared where possible. Every reasonable effort has been made by the publisher (UCLES) to trace copyright holders, but if any items requiring clearance have unwittingly been included the publisher will be pleased to make amends at the earliest possible opportunity.

University of Cambridge International Examinations is part of the Cambridge Assessment Group. Cambridge Assessment is the brand name of University of Cambridge Local Examinations Syndicate (UCLES), which is itself a department of the University of Cambridge.