



UNIVERSITY OF CAMBRIDGE INTERNATIONAL EXAMINATIONS  
International General Certificate of Secondary Education

CANDIDATE  
NAME

CENTRE  
NUMBER

--	--	--	--	--

CANDIDATE  
NUMBER

--	--	--	--

\* 2 8 5 3 9 3 2 8 6 5 \*

**MATHEMATICS**

**0580/31**

Paper 3 (Core)

**May/June 2011**

**2 hours**

Candidates answer on the Question Paper.

Additional Materials:

Electronic calculator  
Mathematical tables (optional)

Geometrical instruments  
Tracing paper (optional)

**READ THESE INSTRUCTIONS FIRST**

Write your Centre number, candidate number and name on all the work you hand in.

Write in dark blue or black pen.

You may use a pencil for any diagrams or graphs.

Do not use staples, paper clips, highlighters, glue or correction fluid.

**DO NOT WRITE IN ANY BARCODES.**

Answer **all** questions.

If working is needed for any question it must be shown below that question.

Electronic calculators should be used.

If the degree of accuracy is not specified in the question, and if the answer is not exact, give the answer to three significant figures. Give answers in degrees to one decimal place.

For  $\pi$ , use either your calculator value or 3.142.

At the end of the examination, fasten all your work securely together.

The number of marks is given in brackets [ ] at the end of each question or part question.

The total of the marks for this paper is 104.

This document consists of **16** printed pages.



1 Mr and Mrs Clark and their three children live in the USA and take a holiday in Europe.

(a) Mr Clark changes \$500 into euros (€) when the exchange rate is €1 = \$1.4593.

Calculate how much he receives.  
Give your answer correct to 2 decimal places.

Answer(a) € ..... [2]

(b) Tickets for an amusement park cost €62 for an adult and €52 for a child.

Work out the cost for Mr and Mrs Clark and their three children to visit the park.

Answer(b) € ..... [3]

(c) Mr Clark sees a notice:

<p style="text-align: center;"><b>SPECIAL OFFER!</b></p> <p style="text-align: center;"><b>Family ticket €200</b></p>
-----------------------------------------------------------------------------------------------------------------------

Work out €200 as a percentage of your answer to **part (b)**.

Answer(c) ..... % [1]

3

- (d) Mrs Clark buys 6 postcards at €0.98 each. She pays with a €10 note.

Calculate how much change she will receive.

Answer(d) € ..... [2]

- (e) Children under a height of 130 cm are not allowed on one of the rides in the park. Helen Clark is 50 inches tall.

Use 1 inch = 2.54 cm to show that she will not be allowed on this ride.

Answer(e)

[1]

---

2

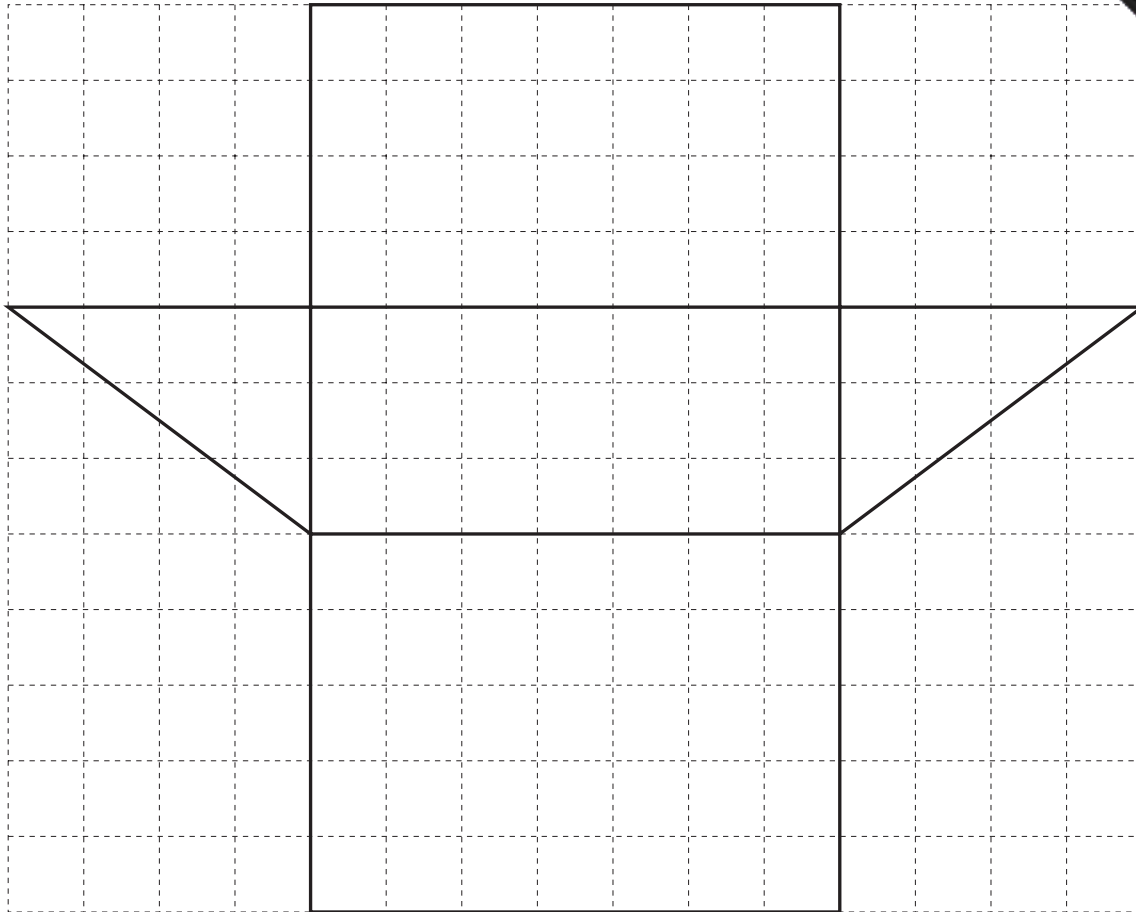

The shape above is the net of a solid drawn on a 1 cm square grid.

(a) Write down the geometrical name of the solid.

Answer(a) ..... [1]

(b) Find the perimeter of the net.

Answer(b) ..... cm [1]

5

(c) Work out

(i) the area of one of the triangles,

Answer(c)(i) ..... cm<sup>2</sup> [2]

(ii) the volume of the solid.

Answer(c)(ii) ..... cm<sup>3</sup> [2]

(d) A cuboid of length 4 cm and width 3 cm has the same volume as the solid.

Calculate the height of the cuboid.

Answer(d) ..... cm [2]

---

3 (a)  $x = 3m - k$

Find the value of

(i)  $x$  when  $m = 2$  and  $k = -4$ ,

Answer(a)(i) ..... [2]

(ii)  $m$  when  $x = 19$  and  $k = 5$ .

Answer(a)(ii) ..... [3]

(b) Expand the brackets.

$$g(7f - g^2)$$

Answer(b) ..... [2]

(c) Factorise completely.

$$18h^2 - 12hj$$

Answer(c) ..... [2]

(d) Make  $m$  the subject of the formula.

$$t = 8m + 15$$

Answer(d)  $m =$  ..... [2]

(e) Solve the equation.

$$p + 3 = 3(p - 5)$$

Answer(e)  $p =$  ..... [3]

4

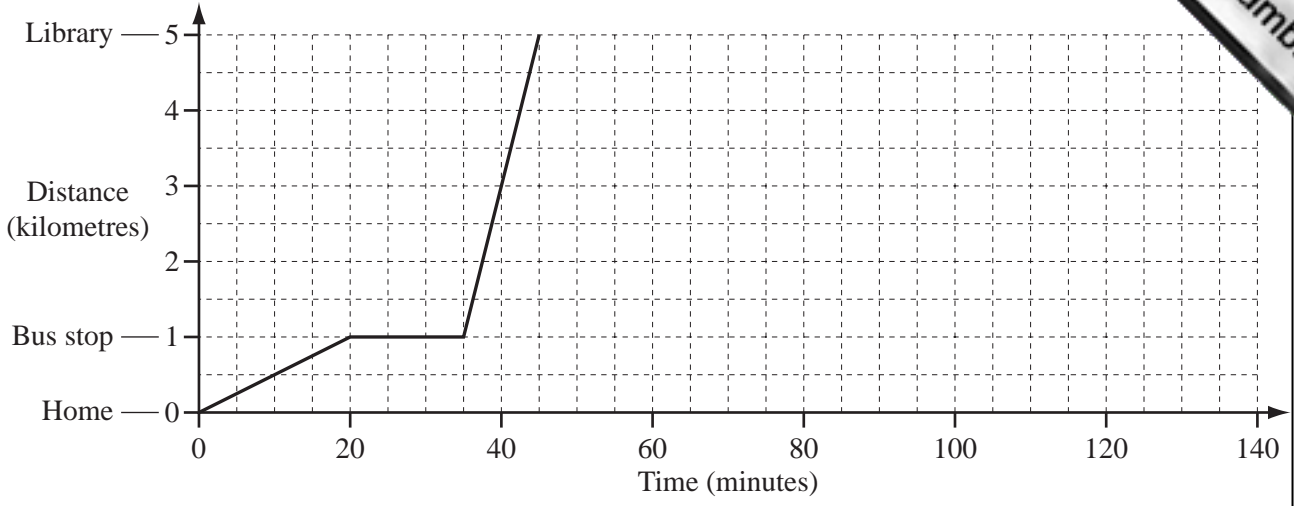

Sonia travels from home to the library.  
 She walks to the bus stop and waits for a bus to take her to the library.

(a) Write down

(i) the distance to the bus stop,  
 Answer(a)(i) ..... km [1]

(ii) how many minutes Sonia waits for a bus,  
 Answer(a)(ii) ..... min [1]

(iii) how many minutes the bus journey takes to the library.  
 Answer(a)(iii) ..... min [1]

(b) Calculate, in kilometres per hour,

(i) Sonia's walking speed,  
 Answer(b)(i) ..... km/h [1]

(ii) the speed of the bus,  
 Answer(b)(ii) ..... km/h [2]

(iii) the average speed for Sonia's journey from home to the library.  
 Answer(b)(iii) ..... km/h [3]

(c) Sonia works in the library for one hour.  
 Then she travels home by car.  
 The average speed of the car is 30 km/h.

Complete the travel graph. [2]

5

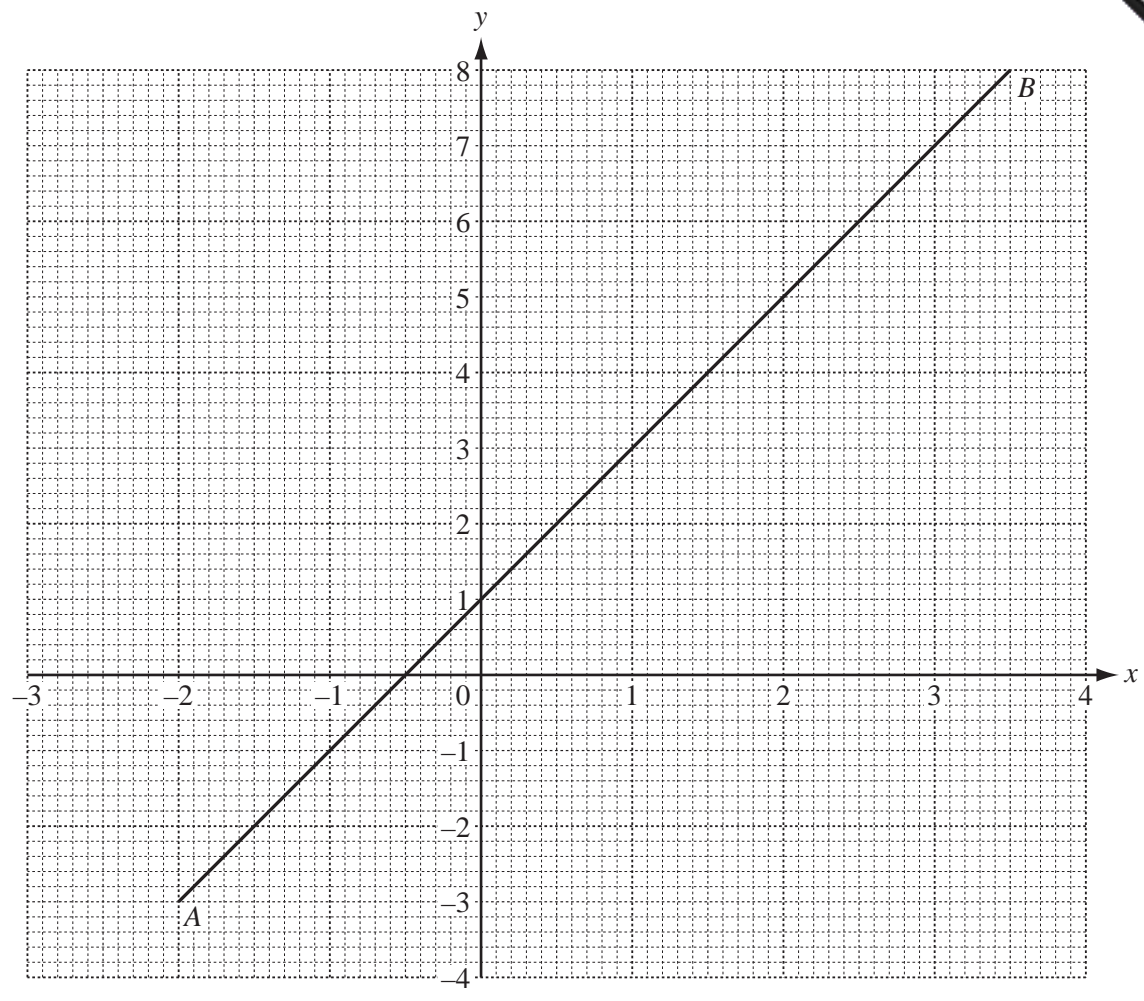

(a) (i) Find the gradient of the line  $AB$ .

Answer(a)(i) ..... [2]

(ii) Write down the equation of the line  $AB$  in the form  $y = mx + c$ .

Answer(a)(ii)  $y =$  ..... [2]



(b) The table shows some values of the function  $y = x^2 - 2$ .

$x$	-3	-2	-1	0	1	2	3
$y$	7		-1		-1		7

- (i) Complete the table. [2]
- (ii) On the grid, draw the graph of  $y = x^2 - 2$  for  $-3 \leq x \leq 3$ . [4]
- (iii) Use your graph to solve the equation  $x^2 - 2 = 0$ .

*Answer(b)(iii)*  $x =$  ..... or  $x =$  ..... [2]

(c) Write down the co-ordinates of the points where your graph meets the line  $AB$ .

*Answer(c)* ( ..... , ..... ) and ( ..... , ..... ) [2]

---

10

- 6 (a) 103 112 125 132 144 159 161

From the list above, write down

(i) a square number,

Answer(a)(i) ..... [1]

(ii) a cube number,

Answer(a)(ii) ..... [1]

(iii) a prime number,

Answer(a)(iii) ..... [1]

(iv) an odd number which is a multiple of 3.

Answer(a)(iv) ..... [1]

(b) Write 88 as a product of prime numbers.

Answer(b) ..... [2]

(c) Find the highest common factor of 72 and 96.

Answer(c) ..... [2]

(d) Find the lowest common multiple of 15 and 20.

Answer(d) ..... [2]



7 (a)

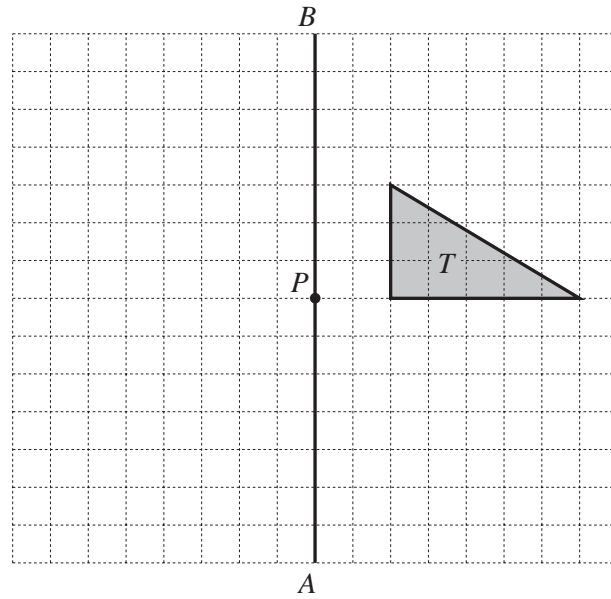

- (i) Reflect triangle  $T$  in the line  $AB$ .  
Label your image  $X$ . [1]
- (ii) Rotate triangle  $T$  through  $90^\circ$  clockwise about the point  $P$ .  
Label your image  $Y$ . [2]

(b)

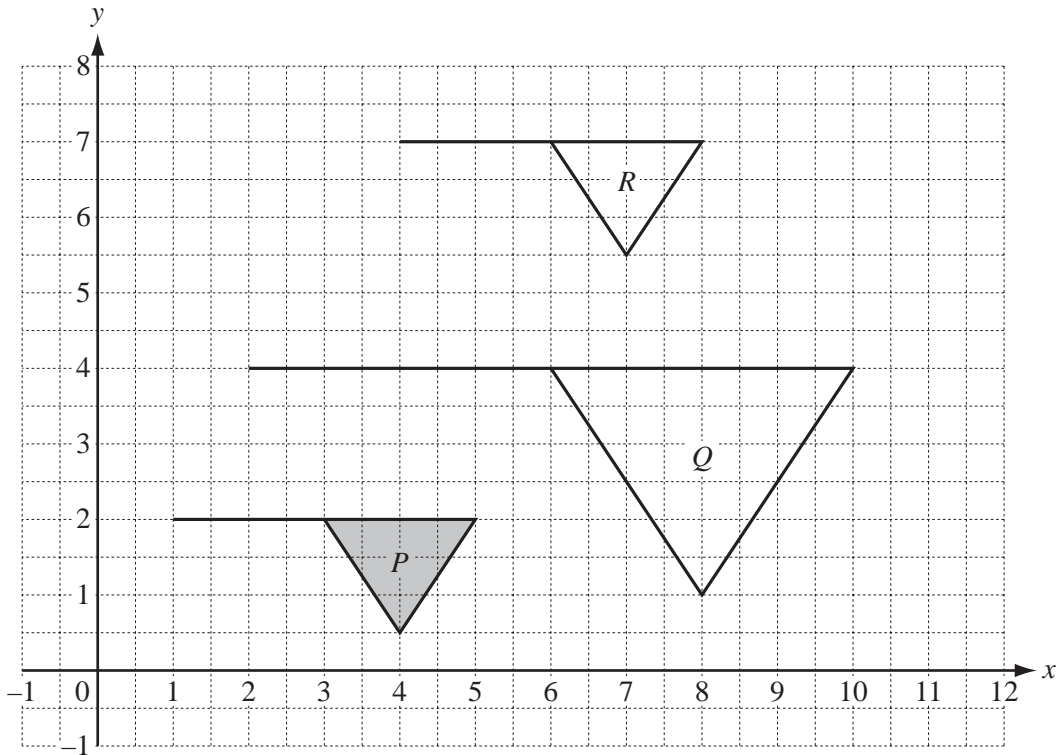

Describe the **single** transformation which maps

- (i) flag  $P$  onto flag  $Q$ ,  
*Answer(b)(i)* ..... [3]

- (ii) flag  $P$  onto flag  $R$ .  
*Answer(b)(ii)* ..... [2]

- 8 30 students took a vocabulary test.  
The marks they scored are shown below.

7	8	5	8	3	2
6	6	3	3	6	2
7	1	5	10	2	6
6	5	8	1	2	7
3	1	5	3	10	3

- (a) Complete the frequency table below.

The first five frequencies have been completed for you.  
You may use the tally column to help you.

Mark	Tally	Frequency
1		3
2		4
3		6
4		0
5		4
6		
7		
8		
9		
10		

[3]

(b) (i) Find the range.

Answer(b)(i) ..... [1]

(ii) Write down the mode.

Answer(b)(ii) ..... [1]

(iii) Find the median.

Answer(b)(iii) ..... [2]

(iv) Calculate the mean.

Answer(b)(iv) ..... [3]

(c) A student is chosen at random.

Find the probability that the student scored

(i) 1 mark,

Answer(c)(i) ..... [1]

(ii) 4 marks,

Answer(c)(ii) ..... [1]

(iii) fewer than 6 marks.

Answer(c)(iii) ..... [1]

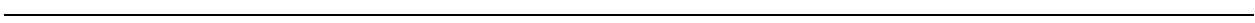

- 9 (a) In the space below, construct the triangle  $ABC$  with  $AB = 10$  cm and  $AC = 12$  cm.  
Leave in your construction arcs.  
The line  $BC$  is already drawn.



[2]

(b) Measure angle  $ABC$ .

Answer(b) Angle  $ABC =$  ..... [1]

(c) (i) Using a straight edge and compasses only, and leaving in your construction arcs, construct the perpendicular bisector of  $BC$ . [2]

(ii) This bisector cuts  $AC$  at  $P$ .

Mark the position of  $P$  on the diagram and measure  $AP$ .

Answer(c)(ii)  $AP =$  ..... cm [1]

(d) Construct the locus of all the points inside the triangle which are 5 cm from  $A$ . [1]

(e) Shade the region inside the triangle which is

- nearer to  $B$  than to  $C$
- and
- less than 5 cm from  $A$ . [2]

Question 10 is printed on the next page.

10 (a)

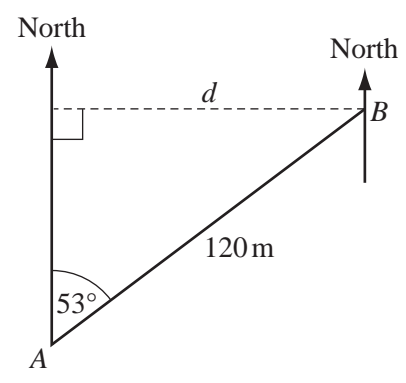

NOT TO SCALE

$B$  is 120 m from  $A$  on a bearing of  $053^\circ$ .  
Calculate

(i) the distance  $d$ ,

Answer(a)(i)  $d =$  ..... m [2]

(ii) the bearing of  $A$  from  $B$ .

Answer(a)(ii) ..... [1]

(b)

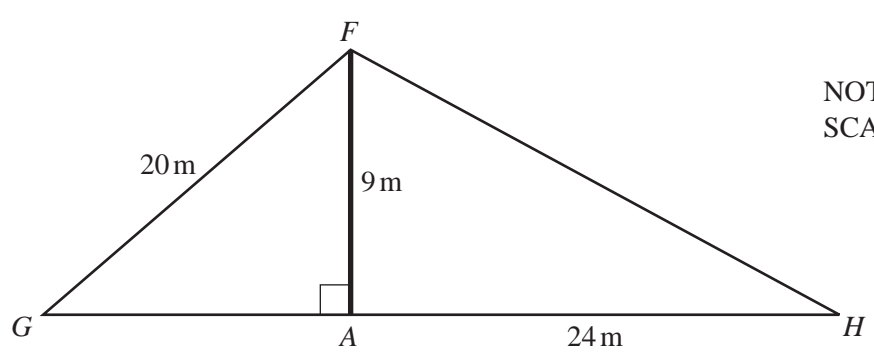

NOT TO SCALE

A vertical flagpole,  $AF$ , is 9 m high.  
It is held in place by two straight wires  $FG$  and  $FH$ .  
 $FG = 20$  m and  $AH = 24$  m.  
 $G$ ,  $A$  and  $H$  lie in a straight line on horizontal ground.  
Calculate

(i) angle  $FHA$ ,

Answer(b)(i) Angle  $FHA =$  ..... [2]

(ii) the distance  $GA$ .

Answer(b)(ii)  $GA =$  ..... m [3]

Permission to reproduce items where third-party owned material protected by copyright is included has been sought and cleared where possible. Every reasonable effort has been made by the publisher (UCLES) to trace copyright holders, but if any items requiring clearance have unwittingly been included, the publisher will be pleased to make amends at the earliest possible opportunity.