



UNIVERSITY OF CAMBRIDGE INTERNATIONAL EXAMINATIONS
International General Certificate of Secondary Education

CANDIDATE NAME

CENTRE NUMBER

CANDIDATE NUMBER

* 5 1 5 6 9 0 4 3 9 9 *

PHYSICAL SCIENCE **0652/62**
Paper 6 Alternative to Practical **October/November 2013**
1 hour

Candidates answer on the Question Paper.
No Additional Materials are required.

READ THESE INSTRUCTIONS FIRST

Write your Centre number, candidate number and name on all the work you hand in.
Write in dark blue or black pen.
You may use a pencil for any diagrams or graphs.
Do not use staples, paper clips, glue or correction fluid.
DO NOT WRITE IN ANY BARCODES.

Answer **all** questions.
Electronic calculators may be used.
You may lose marks if you do not show your working or if you do not use appropriate units.

At the end of the examination, fasten all your work securely together.
The number of marks is given in brackets [] at the end of each question or part question.

This document consists of **20** printed pages.

1 The science teacher is investigating the heating effect of an electric current. The heating apparatus and the electrical circuit are shown in Fig. 1.1.

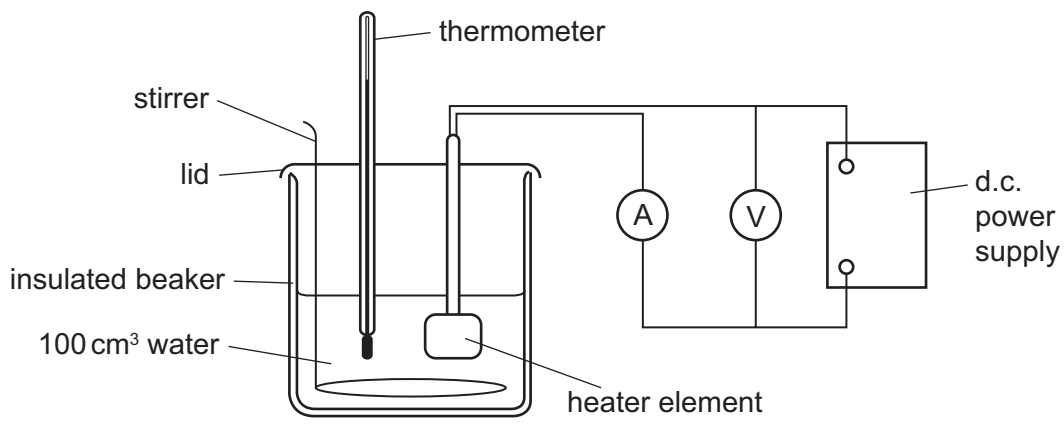

Fig. 1.1

- He places 100cm³ of water in the insulated beaker with the heater, stirrer and thermometer.
- He places the lid on the beaker.
- He reads the temperature of the water, and records it in Table 1.2. (on page 4).
- He switches on the current.
- Every two minutes he reads the temperature to the nearest 0.5°C and records it in Table 1.2.
- He reads the meters and records the current and voltage in Table 1.1.

Table 1.1

current / A	
voltage / V	

(a) (i) Fig. 1.2 shows the ammeter and voltmeter readings during the experiment.

Read the meters to the nearest 0.1 A and 0.5 V and record the results in Table 1.1. [2]

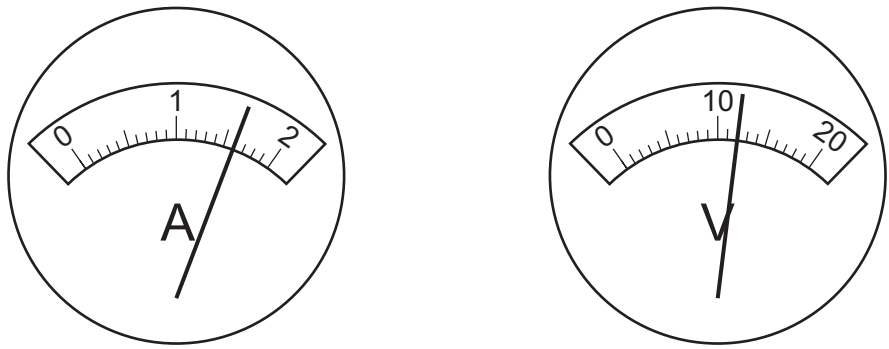

Fig. 1.2

3

(ii) Calculate the power output of the heater.

Use the formula $power = voltage \times current$.

power = W [1]

(iii) Calculate the total energy used by the heater in 10 minutes.

Use the formula $energy = power \times time \text{ in seconds}$.

energy = J [1]

(b) (i) Fig. 1.3 shows the temperatures missing from Table 1.2.

Read the thermometers to the nearest 0.5°C and record the temperatures in Table 1.2 on page 4. [2]

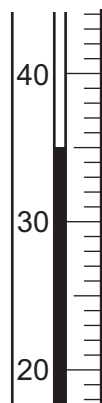

time $t = 6$ minutes

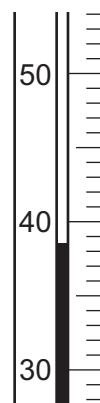

time $t = 8$ minutes

Fig. 1.3

(ii) Calculate the total temperature rise at times $t = 6$ and $t = 8$ minutes and complete Table 1.2 on page 4.

[1]

Table 1.2

time t /minutes	0	2	4	6	8	10
temperature/ $^{\circ}\text{C}$	22.0	26.5	30.5			42.5
temperature rise/ $^{\circ}\text{C}$	0	4.5	8.5			20.5

(c) Explain how the teacher tried to prevent heat loss from the water during the experiment. Fig. 1.1 will help you.

.....
..... [1]

(d) (i) Complete the sentence below.

Electrical energy is transformed to energy during
the experiment. [1]

(ii) Explain how the behaviour of the water molecules changes during the experiment.

.....
.....
..... [1]

Please turn over for Question 2.

2 A student is finding the mass and volume of a metre rule and then calculating the density of the material of which it is made.

The teacher has given him an unknown mass, **M**, to use in the experiment.

The apparatus is shown in Fig. 2.1.

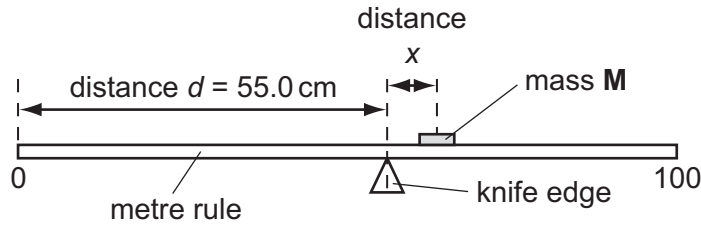

Fig. 2.1

- The student places the knife edge under the 55.0 cm. mark of the rule so that distance $d = 55.0$ cm.
- He places mass **M** on the right-hand side of the rule and adjusts its position until the rule is balanced.
- He records in Table 2.1 the position of mass **M** on the rule and calculates x , the distance between the knife edge and the centre of mass **M**.
- He adjusts the knife edge so that $d = 60.0$ cm.
- He moves mass **M** until the rule is balanced again.
- He records the new position of mass **M**, then calculates and records the new value of x .
- He repeats the procedure for the other values of d shown in Table 2.1.

(a) (i) Fig. 2.2 shows the positions of **M** when $d = 60.0$ cm and 70.0 cm.

For each knife edge position, read the rule and record, in Table 2.1, the position of the centre of **M**. [2]

(ii) Calculate the missing values of x , the distance from the knife edge to the centre of **M**, and record them in Table 2.1.

[2]

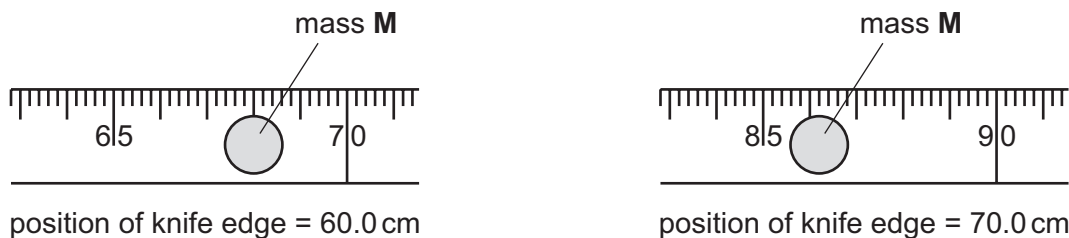
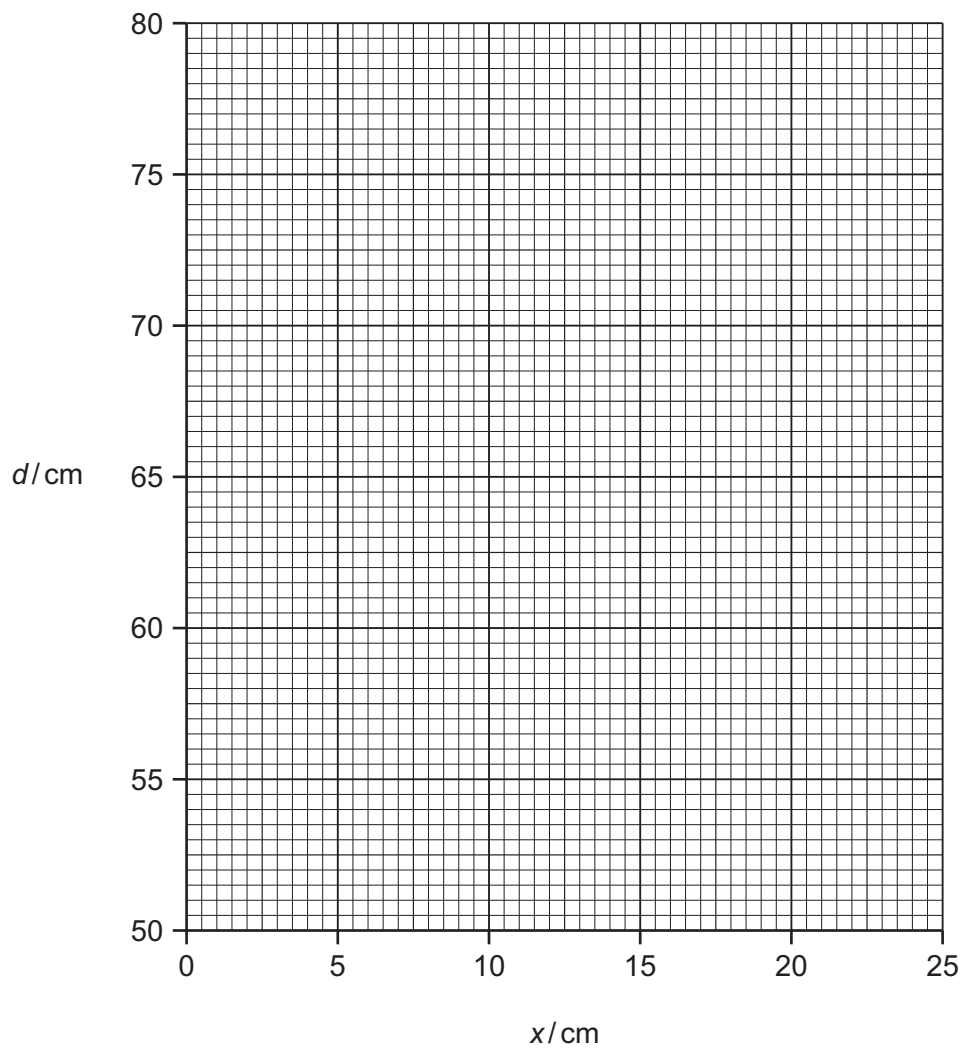

Fig. 2.2

Table 2.1

distance d /cm	position of mass M /cm	distance x /cm
55.0	58.8	3.8
60.0		
65.0	77.1	12.1
70.0		
75.0	94.4	19.9

(b) (i) On the grid provided, plot a graph of d against x . Draw the best straight line.



[2]

(ii) Find the gradient of the line. Show on your graph the values that you calculate the gradient.

gradient = [2]

(c) The teacher says that the mass of the metre rule, m , is given by the equation

$$\text{mass of rule, } m = \frac{150}{\text{gradient}}$$

Use this equation to calculate the mass of the rule.

$m = \dots\dots\dots$ g [1]

(d) The student measures the dimensions of the metre rule, shown in Fig. 2.3. He wants to use the mass and volume of the rule to determine the density of the material.

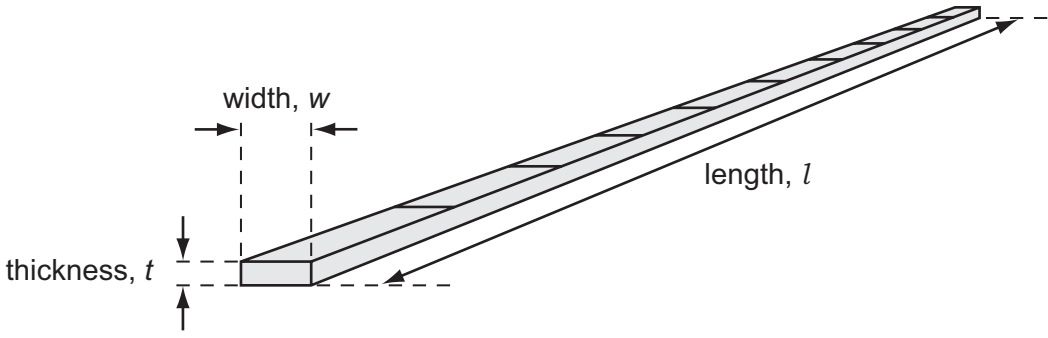

Fig. 2.3

Use the symbols l , w , t and m to write a formula that the student can use to find the density.

density of the material =

[1]

Please turn over for Question 3.

3 A student is carrying out tests to identify the ions present in solution X.

Table 3.1 shows the tests, observations and conclusions that he has made. Complete Table 3.1.

Table 3.1

	test	observation	conclusion
(a) (i)	To a spatula load of solid X, slowly add dilute nitric acid, with shaking, until the solid has dissolved. Divide the solution into two parts, for use in (a)(iii) and (b)(i) .	Some [1] are seen rising in the solution. A green solution is formed.	A gas is given off. Solid X contains ions of metals known as [1]
(ii)	Test the gas given off from (a)(i) using limewater.	The limewater turns [1]	Solid X contains carbonate ions.
(iii)	To the first part of the solution from (a)(i) add an equal volume of aqueous silver nitrate.	A [1] is formed.	Solid X contains chloride ions.
(b) (i)	To the second part of the solution from (a)(i) add ammonia solution, with shaking, until it is in excess. Filter the mixture.	A brown precipitate and a dark blue filtrate are obtained.	The brown precipitate is iron(III) [1]

test	observation	conclusion
<p>(ii) To a sample of the filtrate from (b)(i) add dilute sulfuric acid until the mixture is just acid. Test with</p> <p>..... [1]</p> <p>paper to show that the mixture is acid.</p>	<p>The colour of the mixture of the filtrate with dilute sulfuric acid is</p> <p>..... [1]</p>	<p>The filtrate contains copper(II) ions.</p>
<p>(iii) To a sample of the residue from (b)(i) add hydrochloric acid and shake until it has dissolved.</p>	<p>The colour of the solution is</p> <p>..... [1]</p>	<p>The residue contains iron(III) ions.</p>

(c) The student has concluded that solution **X** contains copper(II), iron(III), chloride and sulfate ions.

Write the name and formula of two salts that could have been used to make solution **X**.

name of salt 1

formula

name of salt 2

formula

[2]

4 The teacher is showing the science class the distillation of crude petroleum. He produces four different fractions. The experiment is shown in Fig. 4.1.

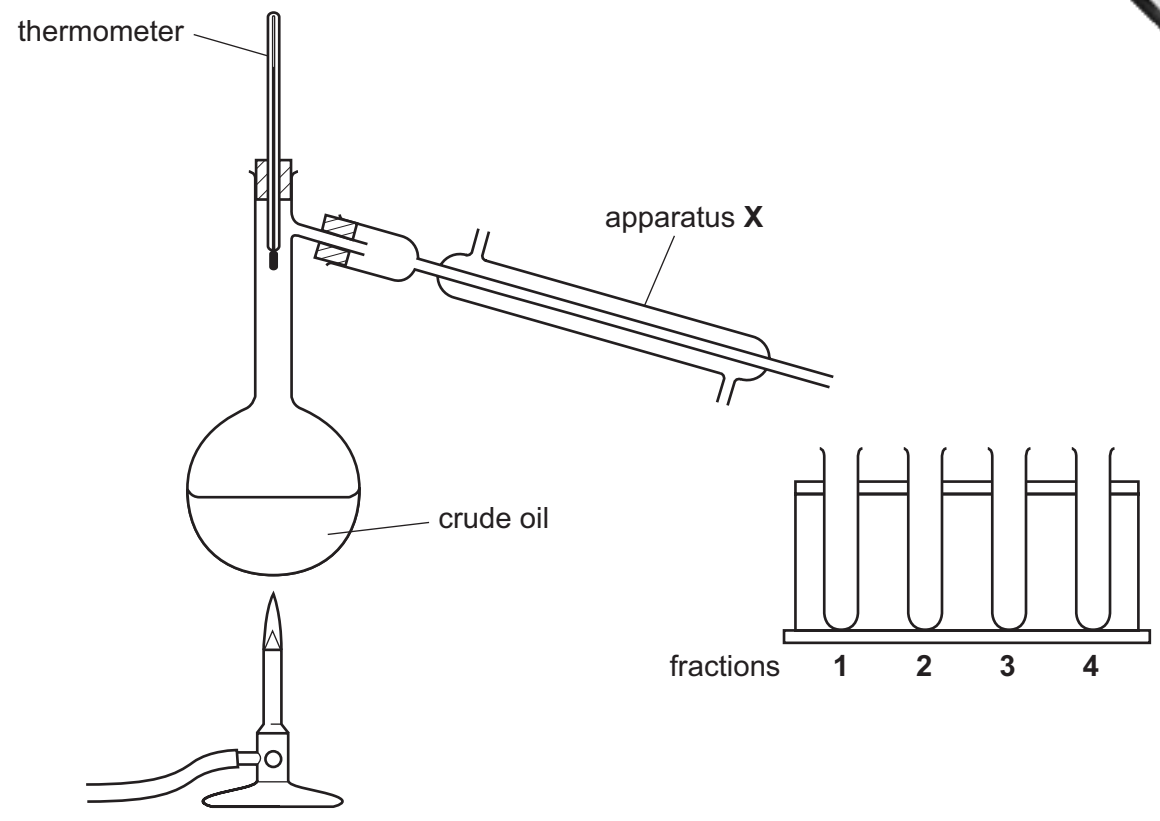

Fig. 4.1

The teacher warms the flask using a small flame. The crude petroleum begins to boil. The vapour of the first fraction reaches the thermometer and passes into the long tube inside the apparatus marked X.

- (a) (i) Name the piece of apparatus marked X. [1]
- (ii) The outer jacket of apparatus X must be kept full of cold running water.

On Fig. 4.1, draw and label arrows to show where the water runs *in* and *out*. [2]

When the temperature of the vapour reaches 120°C the teacher begins to collect the second fraction.

He collects fraction 3 and fraction 4 at higher temperatures. The boiling ranges of the four fractions are shown in Table 4.1.

Table 4.1

fraction number	1	2	3	4
boiling range / °C	60–120	120–150	150–180	180–240

(b) (i) As well as the difference in the boiling range temperatures, suggest **one** physical property that is different for each of the fractions.

..... [1]

(ii) Suggest **one** way in which the molecules in fraction 1 differ from those in fraction 4.

.....
..... [1]

(c) The teacher says that one of the substances in fraction 1 is hexane, a member of the alkane homologous series.

A molecule of hexane contains 6 carbon atoms and 14 hydrogen atoms arranged in a straight chain.

Draw a diagram showing all the atoms and bonds in a molecule of hexane.

[2]

(d) The teacher has placed some of the liquid from fraction 2 in a burner, shown in Fig. 4.2.

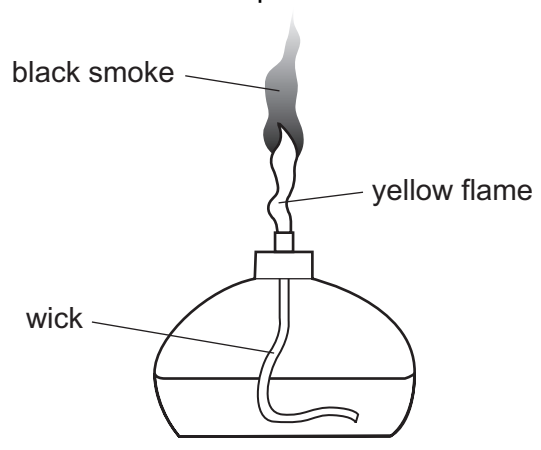

Fig. 4.2

He sets the burner alight. The flame is yellow. Black smoke is seen.

Explain why black smoke comes out of the flame.

.....
.....
..... [2]

(e) When crude oil escapes from a drilling rig, severe damage may be done to the environment

Give **one** example of this damage, stating which petroleum fraction obtained in the experiment above is most likely to cause this type of damage.

.....

.....

..... [1]

Please turn over for Question 5.

- 5 A student is comparing three colourless samples of vinegar, **A**, **B** and **C**. He wants out how much acid is in each sample by titrating with aqueous sodium hydroxide.
- He measures out 50 cm³ of sample **A** and places it in a conical flask.
 - He adds 3 drops of an indicator.
 - He fills a burette to the 0.0 cm³ mark with aqueous sodium hydroxide and adds it drop by drop to the conical flask until the indicator changes colour.
 - He reads the burette scale and records the volume in Table 5.1.
 - He repeats the procedure using samples **B** and **C**.

Table 5.1

sample	A	B	C
volume of aqueous sodium hydroxide used / cm ³			

(a) (i) Fig. 5.1 shows the burette scales for samples **A**, **B** and **C**.

Read the scales and enter the volumes in Table 5.1.

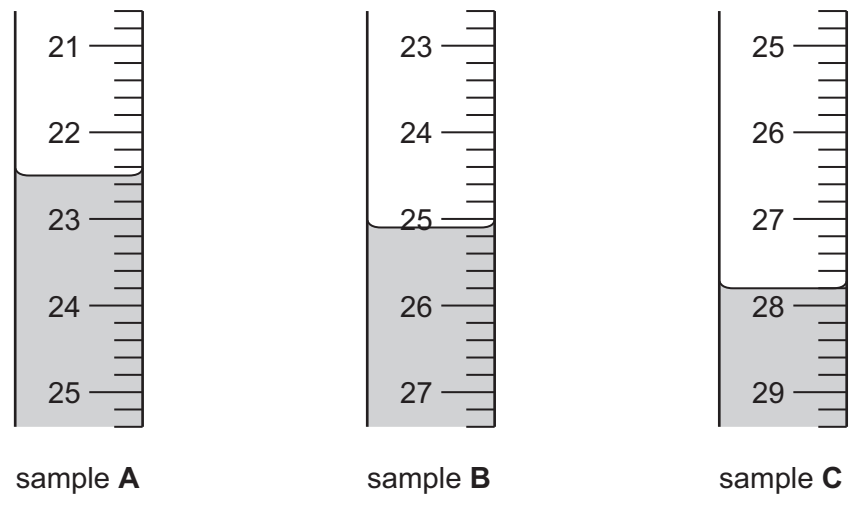

Fig. 5.1

[3]

(ii) Complete the sentence.

..... is the most concentrated sample and
 is the least concentrated sample of vinegar. [1]

(b) (i) Vinegar contains ethanoic acid. During the reaction between vinegar and aqueous sodium hydroxide a salt, sodium ethanoate is formed.

Complete the word equation for the reaction between ethanoic acid and sodium hydroxide to form sodium ethanoate.



(ii) Vinegar is a weak acid.

Suggest what colour Universal Indicator (full-range indicator) will turn if it is added to vinegar.

..... [1]

(c) The student wants to make a sample of sodium ethanoate.

Describe carefully how he can use the results of this experiment to prepare pure dry crystals of sodium ethanoate.

.....

.....

.....

.....

..... [4]

6 The science class is studying waves made by a vibrating spring.

A piece of spring steel about 25 cm long has a pen fixed at one end. The other end is firmly clamped. When the spring is pulled to one side and then released, it vibrates for a few seconds. The pen makes a mark on a piece of paper that is pulled along while the spring is vibrating.

This is shown in Fig. 6.1.

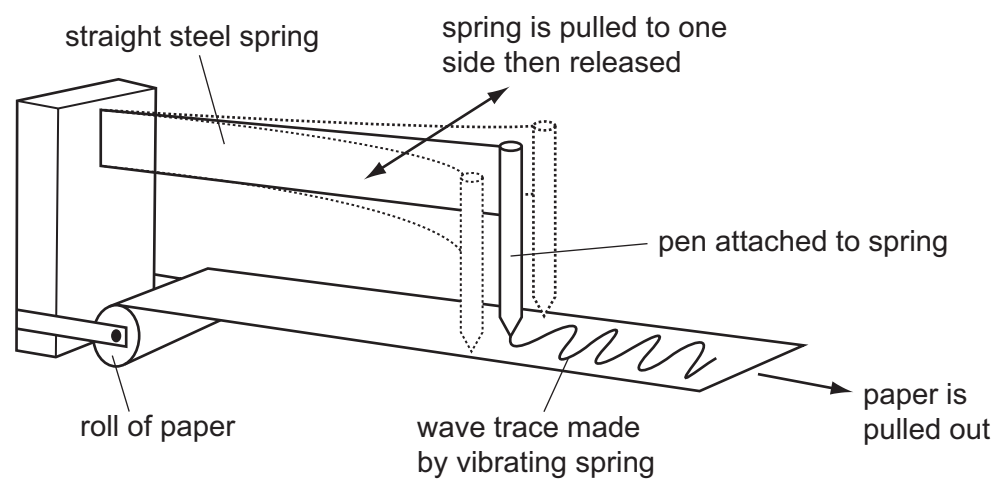

Fig. 6.1

The paper is pulled along at a constant speed. Fig. 6.2 shows the wave drawn by the pen. A student has numbered the waves.

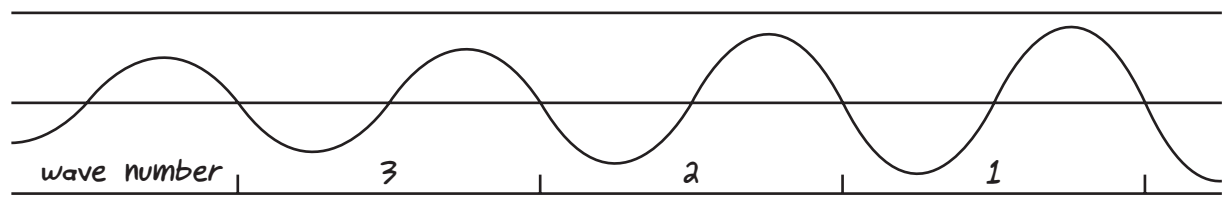

Fig. 6.2

(a) (i) Describe how the amplitude of the wave changes from **wave 1** to **wave 3**.

..... [1]

(ii) Use a ruler to measure to the nearest 0.1 cm the wavelength of one of the waves in Fig. 6.2. Use the marks that the student has made.

wavelength = cm [1]

(iii) The paper moved at a constant speed of 10 cm/s. Use the equation $speed = frequency \times wavelength$ and your answer to part (ii) to calculate the frequency of the waves caused by the vibration of the steel spring.

frequency = Hz [2]

The apparatus shown in Fig. 6.1 is then used to find the acceleration of a trolley rolling down a slope. This is shown in Fig. 6.3.

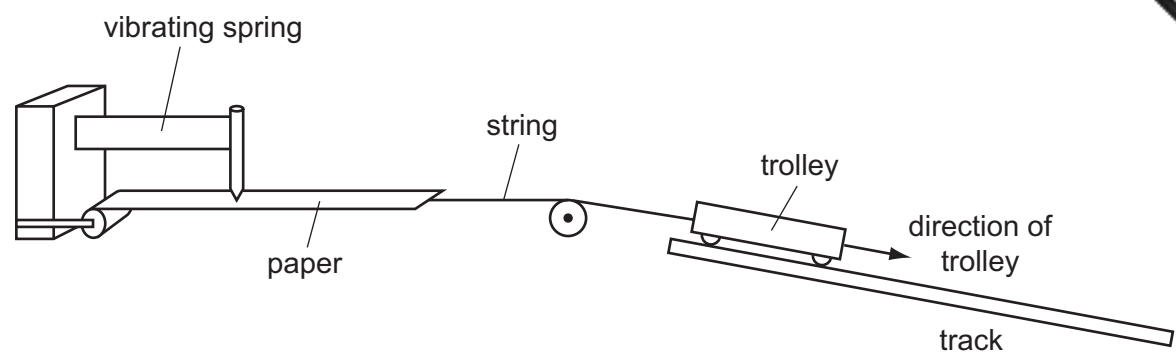

Fig. 6.3

The spring is adjusted so that it vibrates 4 times every second. One complete wave takes 0.25 s.

The trace made by the pen as the trolley moves down the slope is shown in Fig. 6.4. A student has numbered waves 1 – 9 on the trace.

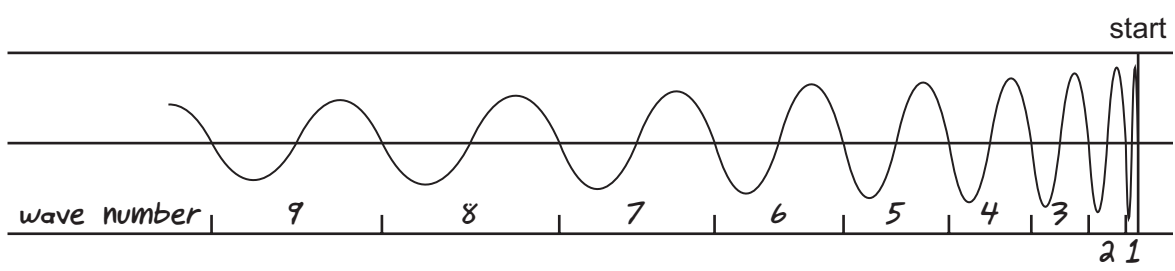

Fig. 6.4

(b) (i) Use a ruler to measure the wavelength of wave 4 to the nearest 0.1 cm. Use the marks that the student has made.

wavelength = cm [1]

(ii) Calculate the average speed of the trolley at this point on the trace. Remember that one wave takes 0.25 s. Give the units of speed of the trolley.

speed of the trolley at wave 4 = unit [2]

(c) (i) Measure the wavelength of **wave 9** to the nearest 0.1 cm.

wavelength = cm [1]

(ii) Calculate the average speed of the trolley at this point.

speed of the trolley at **wave 9** = [1]

(d) Use your results from parts (b)(ii) and (c)(ii) to show that the trolley accelerates as it moves down the slope.

.....
..... [1]

Permission to reproduce items where third-party owned material protected by copyright is included has been sought and cleared where possible. Every reasonable effort has been made by the publisher (UCLES) to trace copyright holders, but if any items requiring clearance have unwittingly been included, the publisher will be pleased to make amends at the earliest possible opportunity.

University of Cambridge International Examinations is part of the Cambridge Assessment Group. Cambridge Assessment is the brand name of University of Cambridge Local Examinations Syndicate (UCLES), which is itself a department of the University of Cambridge.