



# Cambridge IGCSE™

CANDIDATE  
NAME

CENTRE  
NUMBER

--	--	--	--	--	--

CANDIDATE  
NUMBER

--	--	--	--

## PHYSICAL SCIENCE

0652/42

Paper 4 Theory (Extended)

October/November 2020

1 hour 15 minutes

You must answer on the question paper.

No additional materials are needed.

### INSTRUCTIONS

- Answer **all** questions.
- Use a black or dark blue pen. You may use an HB pencil for any diagrams or graphs.
- Write your name, centre number and candidate number in the boxes at the top of the page.
- Write your answer to each question in the space provided.
- Do **not** use an erasable pen or correction fluid.
- Do **not** write on any bar codes.
- You may use a calculator.
- You should show all your working and use appropriate units.

### INFORMATION

- The total mark for this paper is 80.
- The number of marks for each question or part question is shown in brackets [ ].
- The Periodic Table is printed in the question paper.

This document has **24** pages. Blank pages are indicated.



1 Fig. 1.1 shows a small irregularly shaped rock.

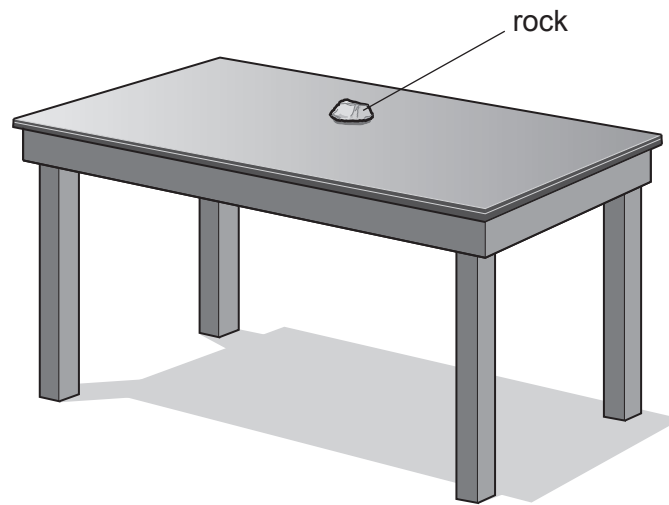

Fig. 1.1

(a) (i) State the name of the apparatus used to find the mass of the rock.

..... [1]

(ii) Describe an experimental procedure that is used to find the volume of the irregularly shaped rock.

Include in your description the readings which must be taken and how the value is calculated.

.....  
.....  
.....  
.....  
..... [3]

(b) The mass of the rock is 150g and its volume is 35 cm<sup>3</sup>.

Calculate the density of the rock.

density = ..... g/cm<sup>3</sup> [2]

3

(c) A student pushes a different rock, of mass 12 kg, up the slope shown in Fig. 1.2.

[ $g = 10 \text{ N/kg}$ ]

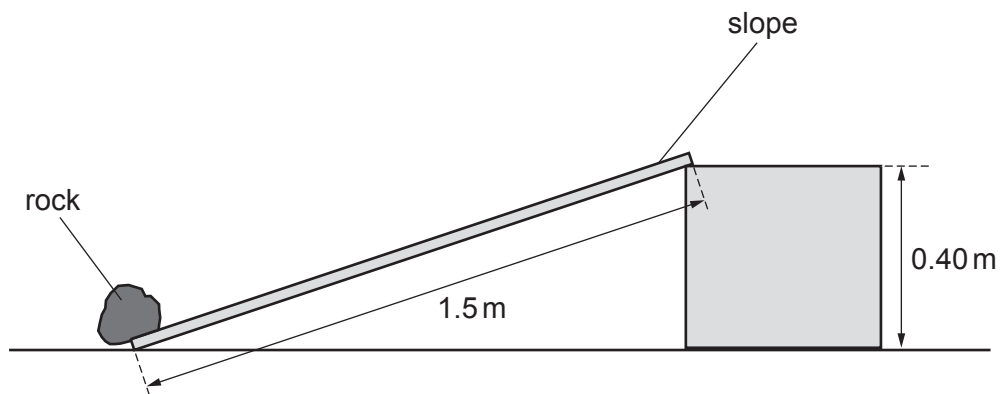

Fig. 1.2

(i) Calculate the work that the student does against gravity.

work done = ..... J [2]

(ii) Name **one** other force that the student does work against while pushing the rock up the slope.

..... [1]

[Total: 9]

2 Three states of matter are solid, liquid and gas.

(a) Complete Table 2.1 to compare the structure of a liquid and a gas in terms of particle separation, particle arrangement and particle motion.

**Table 2.1**

	liquid	gas
particle separation	..... .....	..... .....
particle arrangement	..... .....	..... .....
particle motion	..... .....	..... .....

[4]

(b) Fig. 2.1 shows how the temperature of a substance varies when it is cooled for a period of time.

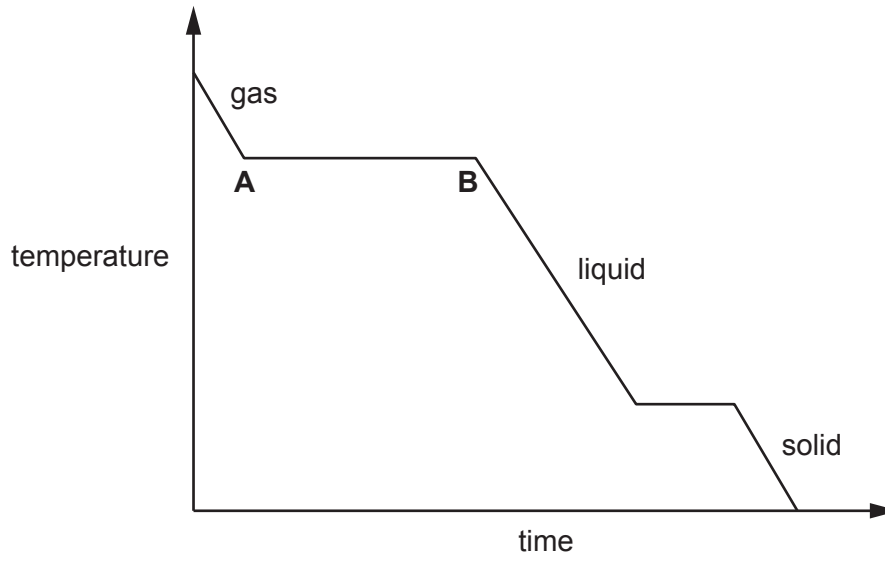

Fig. 2.1

Explain what is happening between points A and B on the graph.

.....

.....

.....

.....

.....

.....

..... [3]

[Total: 7]

3 Fig. 3.1 shows the electromagnetic spectrum.

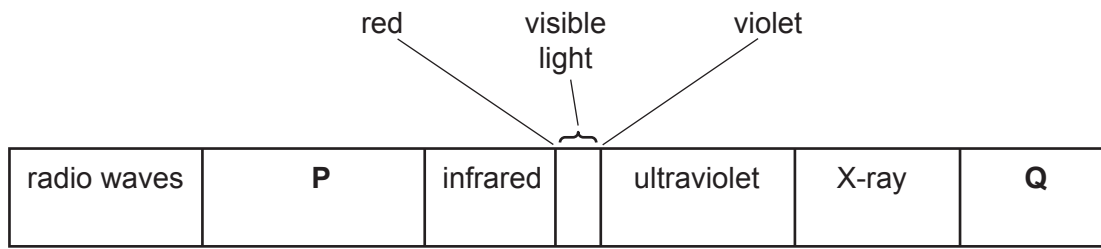

Fig. 3.1

(a) Name the electromagnetic radiation found at P and Q.

P .....

Q .....

[2]

(b) Fig. 3.2 shows apparatus used to disperse sunlight into the colours of the spectrum.

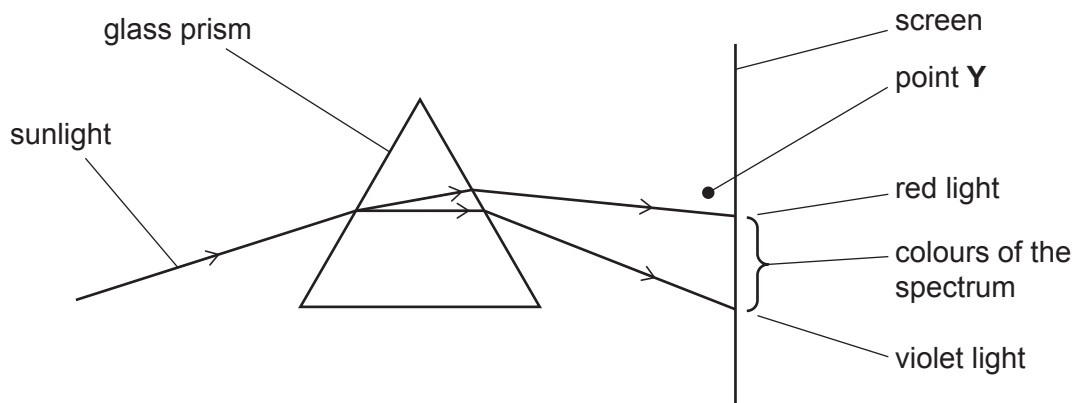

Fig. 3.2

A thermometer is placed at point Y.

The temperature shown by the thermometer rises.

(i) Suggest why the temperature rises.

.....  
 ..... [1]

(ii) The bulb of the thermometer is painted black.

State why this increases the temperature rise.

.....  
 ..... [1]

(c) Sound waves are not part of the electromagnetic spectrum.

Sound waves need a medium in which to travel.

Explain, in terms of molecular movement and separation, how a sound wave passes through a medium.

.....

.....

.....

..... [3]

[Total: 7]

4 A chemist has two samples, **A** and **B**, of medicinal drugs.

The chemist thinks that the samples are a drug called aspirin.

The chemist investigates the melting point of each drug sample.

The results are shown in Table 4.1.

**Table 4.1**

sample	melting point / °C
<b>A</b>	131–132
<b>B</b>	130–134

The melting point of aspirin is 135 °C.

(a) Explain why the samples do **not** have an exact melting point of 135 °C.

.....

.....

.....

..... [2]



- (b) The chemist decides to use chromatography to confirm whether the samples are aspirin.

The chemist dissolves the samples to form solutions and compares them with a known sample of aspirin solution.

The result is called a chromatogram.

- (i) All of the sample solutions are colourless.

State how the results can be made visible on the chromatogram.

.....  
..... [1]

- (ii) Describe how the chemist uses the chromatogram to confirm whether the samples are aspirin.

.....  
.....  
.....  
..... [2]

- (c) The molecular formula for aspirin is  $C_9H_8O_4$ .

Determine the relative molecular mass,  $M_r$ , of aspirin.

[ $A_r$ : C, 12; H, 1; O, 16]

$M_r$  of aspirin = ..... [1]

(d) The structure of aspirin is shown in Fig. 4.1.

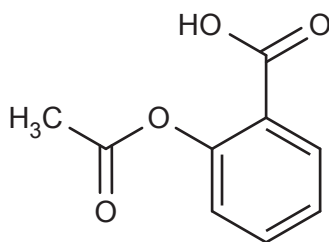

Fig. 4.1

Explain why the structure shows that aspirin is **not** an alkane.

.....  
 ..... [1]

(e) Aspirin reacts with sodium hydroxide to form a salt with sodium.

Table 4.2 shows the charges on an aspirin ion and a sodium ion.

Table 4.2

name	formula of ion	charge of ion
aspirin ion	$C_9H_7O_4^-$	-1
sodium ion	$Na^+$	+1

Determine the formula of the ionic compound formed when the aspirin ion and sodium ion combine.

..... [1]

(f) Aspirin contains the element carbon.

Two isotopes of carbon are carbon-12 and carbon-13.

(i) Explain how these two isotopes are different from each other.

.....  
 ..... [1]

(ii) Explain why the isotopes of carbon have the same chemical properties.

.....  
 ..... [1]

[Total: 10]

**Question 5 begins over the page**

5 An object **O** is placed in front of a plane mirror.

Fig. 5.1 shows the position of the object **O** and a partially completed ray diagram.

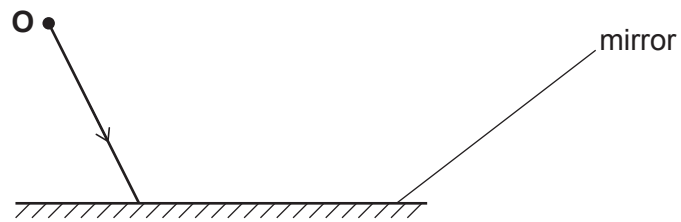

**Fig. 5.1**

(a) On Fig. 5.1:

- complete the ray diagram to show the path of the ray after reflection
- mark the position of the image of the object and label it **I**.

[2]

(b) A candle is placed in front of a converging lens.

Fig. 5.2 shows two rays of light leaving the tip of the candle flame.

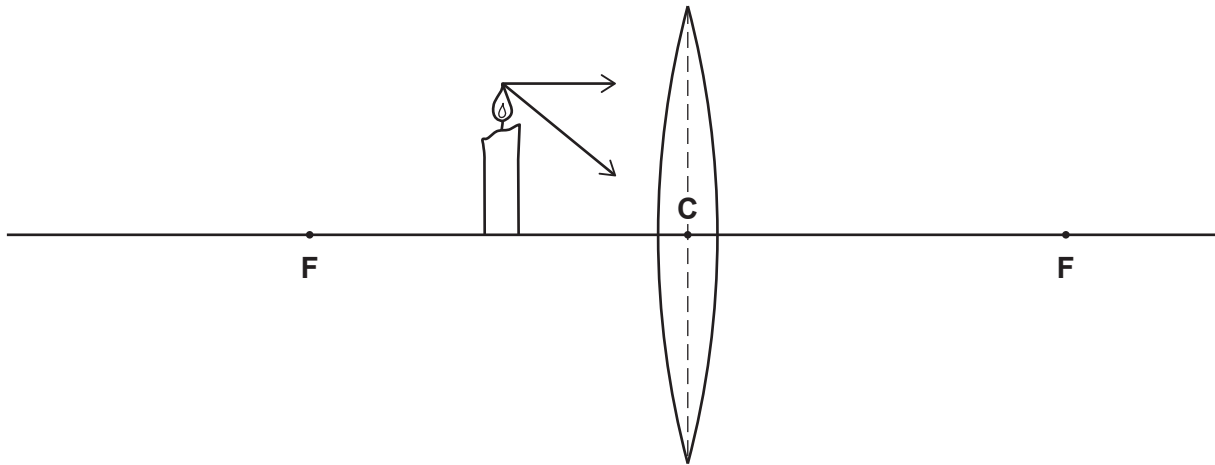

Fig. 5.2

The points labelled **F** are the principal foci of the lens.

Point **C** is the centre of the lens.

On Fig. 5.2, complete:

- (i) the rays of light to show their paths as they approach the lens and pass through it [2]
- (ii) the diagram to show how and where the image is formed. [2]

(c) The image formed in (b) is upright.

State **two** other characteristics of the image.

1 .....

2 ..... [2]

[Total: 8]

14

6 Nitrogen and hydrogen react to form ammonia,  $\text{NH}_3$ .

(a) The equation for the reaction is shown.

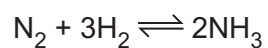

Calculate the mass of ammonia that can be produced from 4.0g of nitrogen.

[ $A_r$ : N, 14; H, 1]

mass of  $\text{NH}_3$  = ..... g [3]

(b) A molecule of nitrogen has the formula  $N_2$ .

Draw a dot-and-cross diagram to represent the bonding in a molecule of nitrogen,  $N_2$ .

Only show the outer electrons of each atom.

[3]

(c) Nitrogen monoxide is a pollutant produced in car engines.

(i) Write **two** word equations that show how nitrogen monoxide is removed by a catalytic converter.

1 .....

2 .....

[2]

(ii) State the role of the catalyst in the catalytic converter.

.....

..... [1]

[Total: 9]

- 7 The circuit in Fig. 7.1 shows a battery of electromotive force (e.m.f.) 6.0 V connected in a circuit. The circuit also includes a thermistor, a resistor of resistance  $3.0\ \Omega$  and a lamp of fixed resistance  $6.0\ \Omega$ .

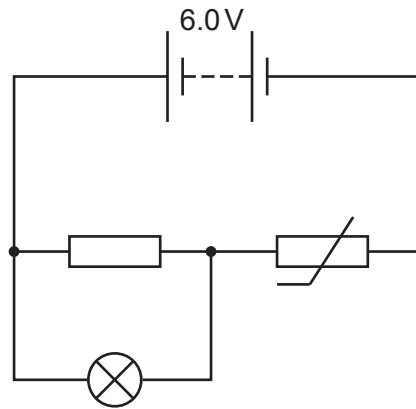

**Fig. 7.1**

- (a) (i) The resistor and the lamp are connected in parallel.  
Calculate the resistance of this combination.

resistance = .....  $\Omega$  [2]

- (ii) The resistance of the thermistor is  $48\ \Omega$ .  
Calculate the total resistance in the circuit.

resistance = .....  $\Omega$  [1]

- (iii) Calculate the current in the battery.

current = ..... A [2]

- (iv) Calculate the potential difference (p.d.) across the thermistor.

potential difference = ..... V [2]



(b) The temperature increases.

(i) Explain why the lamp shines more brightly when the temperature of the thermistor increases.

.....  
.....  
..... [2]

(ii) Suggest **one** use of this circuit.

.....  
..... [1]

[Total: 10]

- 8 Fig. 8.1 shows the structure of an organic compound, 3-bromo-cyclohexan-1-ol.

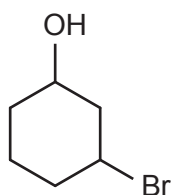

**Fig. 8.1**

The *cyclo* part of the name of this compound is because there is a ring shape,  .  
The *hex* part is because there are six carbon atoms.  
The *bromo* part is because the compound contains a bromine atom.

- (a) Describe what the *-ol* part of the name refers to.

..... [1]

- (b) The equation shows the formation of an alcohol,  $\text{CH}_3\text{CH}_2\text{OH}$ .

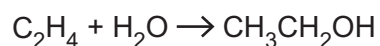

State the type of reaction this equation represents.

..... [1]

- (c) The rate of this reaction increases with increasing temperature.

Explain why.

.....  
.....  
.....  
..... [2]

(d) Fig. 8.2 shows an energy level diagram for an endothermic reaction.

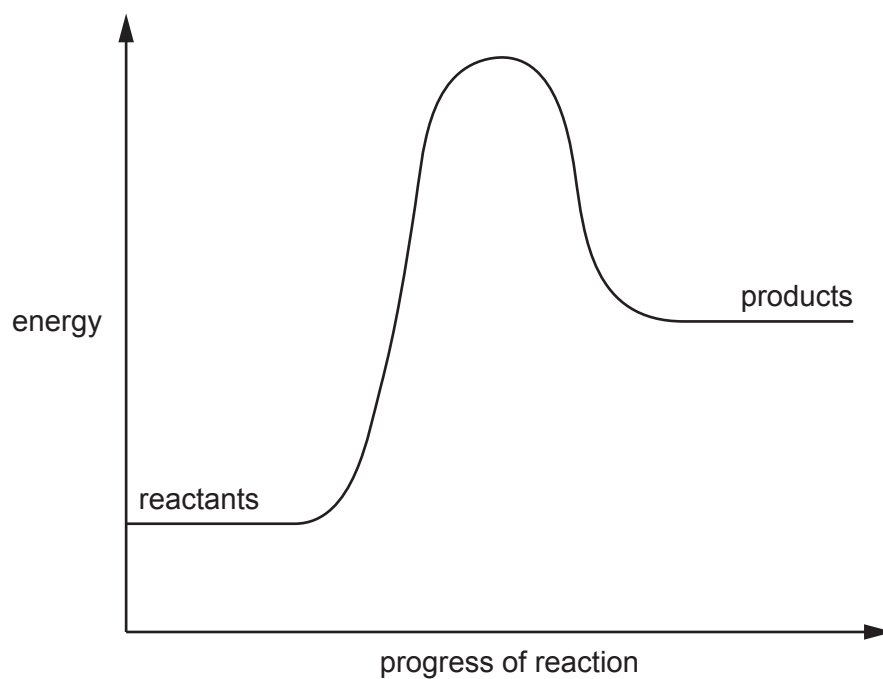

**Fig. 8.2**

On Fig. 8.2, use labelled arrows to show:

- the activation energy
- the overall change in energy.

[2]

[Total: 6]

- 9 A radioactive source emits both  $\alpha$ -particles and  $\beta$ -particles.

Fig. 9.1 shows the path of  $\alpha$ -particles from the source as they pass through a uniform electric field.

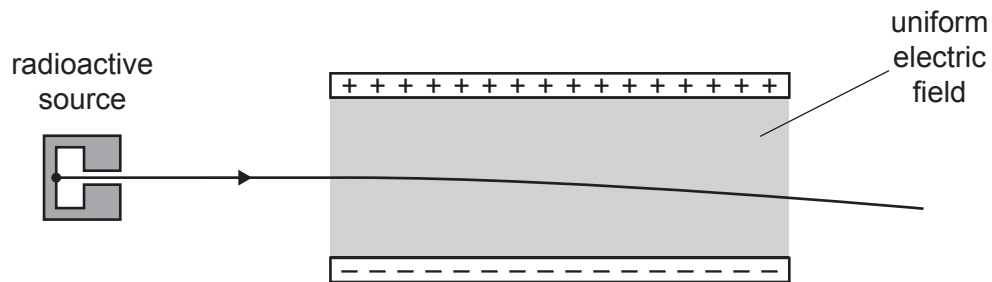

**Fig. 9.1**

- (a) Explain why the  $\alpha$ -particles follow the curved path shown in Fig. 9.1.

.....  
 .....  
 ..... [2]

- (b) The  $\beta$ -particles travel at a similar speed to the  $\alpha$ -particles.

On Fig. 9.1, draw the path of the  $\beta$ -particles in the electric field. [2]

- (c) The isotope polonium-209 ( $^{209}_{84}\text{Po}$ ) decays by emitting an  $\alpha$ -particle.

Complete the equation showing this decay.

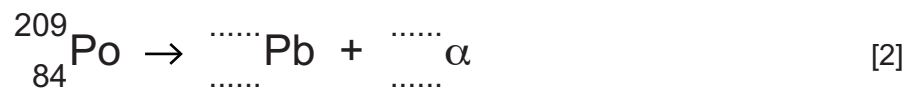

[Total: 6]

10 Chlorine and bromine are halogens in Group VII of the Periodic Table.

(a) (i) Complete the word equation for the reaction of chlorine with aqueous sodium bromide.

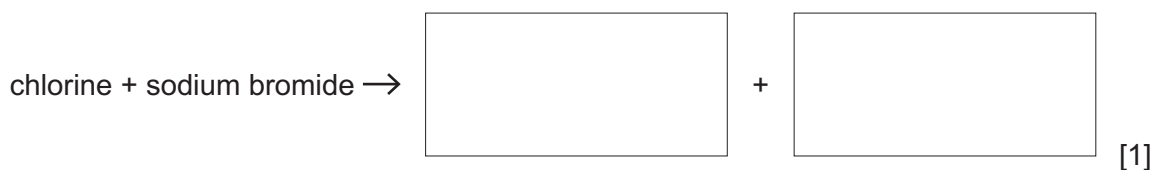

(ii) In this reaction, the chlorine is reduced and the bromide ions are oxidised.

State the name of this type of reaction.

..... [1]

(b) Predict the outcome of adding astatine to aqueous sodium chloride.

Give a reason for your answer.

.....  
 .....  
 .....  
 ..... [2]

(c) Data about Group VII elements are shown in Table 10.1.

**Table 10.1**

element	symbol	melting point /°C	boiling point /°C	state at room temperature	colour
fluorine	F	-219	-188	gas	.....
chlorine	Cl	.....	-34	gas	yellow-green
bromine	Br	-7	59	.....	red-brown
iodine	.....	114	184	solid	purple
astatine	At	300	350	solid	black

Complete Table 10.1. [4]

[Total: 8]



**BLANK PAGE**

---

Permission to reproduce items where third-party owned material protected by copyright is included has been sought and cleared where possible. Every reasonable effort has been made by the publisher (UCLES) to trace copyright holders, but if any items requiring clearance have unwittingly been included, the publisher will be pleased to make amends at the earliest possible opportunity.

To avoid the issue of disclosure of answer-related information to candidates, all copyright acknowledgements are reproduced online in the Cambridge Assessment International Education Copyright Acknowledgements Booklet. This is produced for each series of examinations and is freely available to download at [www.cambridgeinternational.org](http://www.cambridgeinternational.org) after the live examination series.

Cambridge Assessment International Education is part of the Cambridge Assessment Group. Cambridge Assessment is the brand name of the University of Cambridge Local Examinations Syndicate (UCLES), which itself is a department of the University of Cambridge.

