



Cambridge IGCSE™

CANDIDATE
NAME
CENTRE
NUMBER

--	--	--	--	--

CANDIDATE
NUMBER

--	--	--	--

**PHYSICAL SCIENCE****0652/51**

Paper 5 Practical Test

October/November 2020**1 hour 15 minutes**

You must answer on the question paper.

You will need: The materials and apparatus listed in the confidential instructions

INSTRUCTIONS

- Answer **all** questions.
- Use a black or dark blue pen. You may use an HB pencil for any diagrams or graphs.
- Write your name, centre number and candidate number in the boxes at the top of the page.
- Write your answer to each question in the space provided.
- Do **not** use an erasable pen or correction fluid.
- Do **not** write on any bar codes.
- You may use a calculator.
- You should show all your working and use appropriate units.

INFORMATION

- The total mark for this paper is 40.
- The number of marks for each question or part question is shown in brackets [].
- Notes for use in qualitative analysis are provided in the question paper.

For Examiner's Use	
1	
2	
3	
4	
Total	

This document has **16** pages. Blank pages are indicated.

1 You are going to investigate the reaction between magnesium ribbon and hydrochloric acid.

(a) (i) **Procedure**

- Measure 25 cm³ of hydrochloric acid using a measuring cylinder. Pour this into a boiling tube.
- Measure the initial temperature of the hydrochloric acid. Record this temperature to the nearest 0.5 °C in Table 1.1 in the row for one piece of magnesium ribbon.
- Add one piece of magnesium ribbon to the hydrochloric acid in the boiling tube and measure the highest temperature reached. Record this temperature to the nearest 0.5 °C in Table 1.1.
- Rinse the boiling tube and thermometer.
- Repeat the procedure using two, three and four pieces of magnesium ribbon.

Table 1.1

number of pieces of magnesium ribbon	initial temperature of hydrochloric acid / °C	highest temperature reached / °C	temperature rise / °C
1			
2			
3			
4			

[3]

(ii) Calculate the rise in temperature for each reaction.
Record these values in Table 1.1.

[1]

(b) Describe **two** observations that show that the magnesium has reacted completely with the hydrochloric acid.

observation 1

observation 2

[2]

(c) Describe the relationship between the number of pieces of magnesium ribbon and the temperature rise of the reaction.

.....

..... [1]

(d) State **one** variable that must be controlled during this reaction.

..... [1]

(e) Procedure

- Measure 10 cm³ of hydrochloric acid and pour it into a boiling tube.
- Add 5 drops of universal indicator (full range indicator).
- Record the colour of the solution in the boiling tube.
- Add pieces of magnesium ribbon slowly until no more reacts.
- Record the colour changes which take place in the boiling tube.
- Test the gas given off and identify it.

(i) State the colour of the universal indicator in hydrochloric acid.

Describe the colour changes which take place in the boiling tube as the magnesium reacts.

colour of universal indicator in hydrochloric acid

colour changes in boiling tube

.....

[1]

(ii) Describe the test you used to identify the gas given off.

State the observation that identifies the gas and state the identity of the gas.

test

observation

identity

[2]

(f) One way to investigate the rate of the reaction between magnesium and hydrochloric acid is to collect the gas given off and measure the volume of gas collected every minute.

Draw a **labelled** diagram of the assembled apparatus used for this experiment.

You are **not** to do this experiment.

[2]

[Total: 13]

2 You are going to investigate the magnification produced by a converging lens.

Refer to Fig. 2.1 when following the instructions.

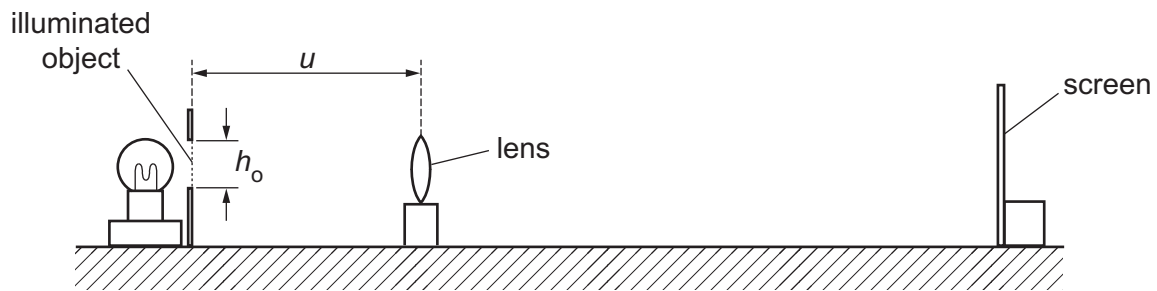

Fig. 2.1

(a)

- Switch on the lamp.
- Set the distance u between the illuminated object and the lens to 25.0 cm.
- Move the screen until a sharp image of the triangle is seen on the screen.
- Measure the height h_i of the image on the screen and record your value in Table 2.1.
- Repeat the procedure for values of $u = 30.0$ cm, 35.0 cm, 40.0 cm and 45.0 cm.
- Switch off the lamp.

Table 2.1

u /cm	h_i /cm	J
25.0		
30.0		
35.0		
40.0		
45.0		

- Measure and record the height h_o of the triangular-shaped hole of the illuminated object.

$$h_o = \dots\dots\dots \text{ cm [1]}$$

(b) Calculate a value of a quantity J for each value of u , using your measurements for h_o and h_i in (a).

Use the equation:

$$J = \frac{h_o}{h_i}$$

Record the values in Table 2.1.

[1]

- (c) (i) Plot a graph of u (vertical axis) against J .

You do not have to start your graph at the origin (0, 0).

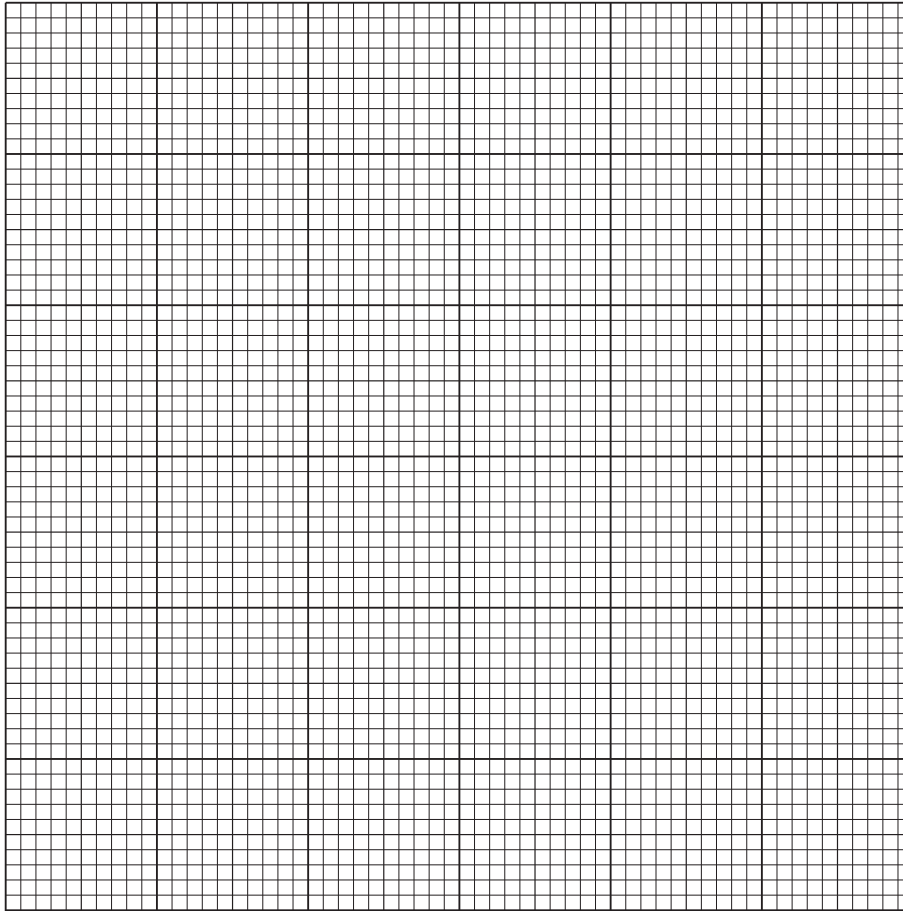

[3]

- (ii) Draw the line of best fit.

[1]

- (d) Calculate the gradient G of the line.

Show all working and indicate on your graph the points you used to calculate the gradient.

$G = \dots\dots\dots$ [2]

- (e) State **one** precaution that you take in this experiment to obtain accurate readings.

.....
 [1]

- (f) One difficulty in measuring the height of the image is that the ruler and your hand cast a shadow over the image.

Suggest an improvement to the apparatus or the arrangement of the apparatus to overcome this difficulty.

.....
..... [1]

[Total: 10]

Question 3 begins over the page

- 3 You are going to investigate the stretching of two identical springs. One of the springs has been set up for you as shown in Fig. 3.1.

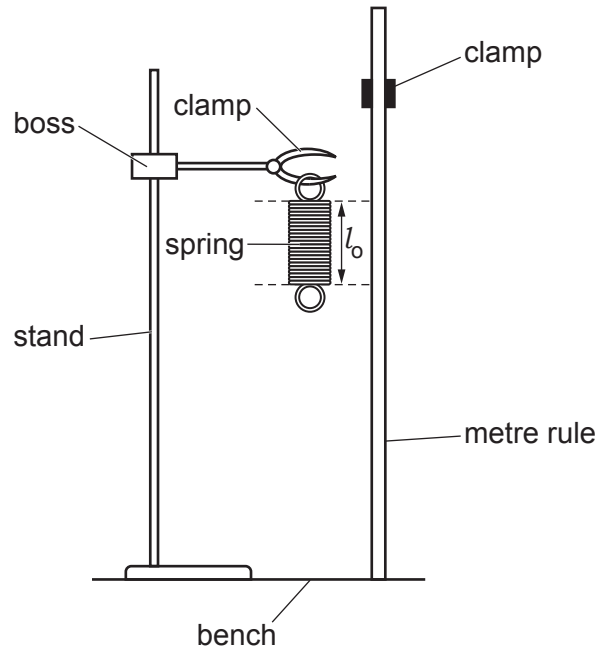

Fig. 3.1

(a) (i)

- Do not remove the spring from the clamp.
- Measure the unstretched length l_0 of the spring in centimetres, to the nearest millimetre. Do not include the loops at the end of the spring in your measurement.

$l_0 = \dots\dots\dots$ cm

- Record l_0 in Table 3.1 at load $L = 0.0\text{ N}$.
- Place a load $L = 1.0\text{ N}$ on the spring.
- Use the metre rule to measure the new length l of the coiled part of the spring in centimetres to the nearest millimetre.

$l = \dots\dots\dots$ cm

- Record l in Table 3.1 at load $L = 1.0\text{ N}$.
- Repeat the procedure using loads of 2.0 N and 3.0 N .

Table 3.1

L/N	l/cm	x/cm
0.0		
1.0		
2.0		
3.0		

[2]

(ii) Calculate the extension x of the spring for each load in Table 3.1.

Use the equation:

$$x = l - l_0$$

[1]

(b) Calculate the spring constant k_1 of the spring when $L = 3.0\text{N}$.

Use the equation:

$$k_1 = \frac{L}{x}$$

where x is the extension of the spring at $L = 3.0\text{N}$.

Give your answer to a suitable number of significant figures.

$$k_1 = \dots\dots\dots \text{N/cm} \quad [2]$$

- (c) (i)
- Remove the loads from the spring.
 - Attach a second identical spring to the bottom of the first spring by linking the loops. Do not remove the spring from the clamp. Fig. 3.2 shows how the springs should be arranged.

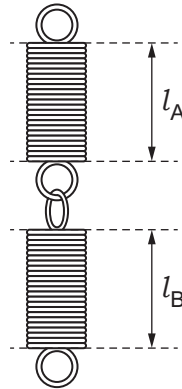

Fig. 3.2

The total length l_C of the coiled part of both springs is the sum of l_A and l_B .

- Use the metre rule to measure the individual lengths l_A and l_B as indicated on Fig. 3.2.
- Calculate and record l_C where:

$$l_C = l_A + l_B$$

$$l_C = \dots\dots\dots \text{ cm}$$

- Place a load $L = 3.0\text{ N}$ on the spring.
- Use the metre rule to measure and record the new individual lengths.
- Calculate and record the new combined length l_D of the coiled part of both springs.

$$l_D = \dots\dots\dots \text{ cm [1]}$$

- (ii) Calculate the extension x_2 of the combined springs.

Use the equation:

$$x_2 = l_D - l_C$$

$$x_2 = \dots\dots\dots \text{ cm [1]}$$

- (d) Calculate the spring constant k_2 of the combined springs when $L = 3.0\text{ N}$.

Use the equation:

$$k_2 = \frac{L}{x_2}$$

$$k_2 = \dots\dots\dots \text{ N/cm [1]}$$

- (e) The student suggests that the spring constant k_2 of the combined springs is equal to half of the spring constant k_1 of just one of the springs.

Explain whether the calculated values of k_1 and k_2 support this suggestion within the limits of experimental error.

.....

 [1]

- (f) The student plans to investigate the relationship between k_1 and k_2 in more detail.

Suggest **one** change to the procedure that will enable the student to do this.

.....

 [1]

[Total: 10]

4 Lemon juice and lime juice both contain acids.

Acids are neutralised by alkalis.

Plan an experiment to compare the amount of acid in lemon juice and lime juice.

You may use any common laboratory apparatus, aqueous sodium hydroxide, any test reagents and a lemon and a lime.

Your plan should include:

- a brief description of the method including the apparatus you would use
- safety precautions AND explain why these are needed
- the variables to control
- the measurements you will make
- an explanation of how you would use your results to reach a conclusion.

A diagram is not required but you may draw one if it helps to explain your plan.

You will **not** be doing this experiment.

.....

.....

.....

.....

.....

NOTES FOR USE IN QUALITATIVE ANALYSIS

Tests for anions

<i>anion</i>	<i>test</i>	<i>test result</i>
carbonate (CO_3^{2-})	add dilute acid	effervescence, carbon dioxide produced
chloride (Cl^-) [in solution]	acidify with dilute nitric acid, then add aqueous silver nitrate	white ppt.
bromide (Br^-) [in solution]	acidify with dilute nitric acid, then add aqueous silver nitrate	cream ppt.
nitrate (NO_3^-) [in solution]	add aqueous sodium hydroxide, then aluminium foil; warm carefully	ammonia produced
sulfate (SO_4^{2-}) [in solution]	acidify, then add aqueous barium nitrate	white ppt.

Tests for aqueous cations

<i>cation</i>	<i>effect of aqueous sodium hydroxide</i>	<i>effect of aqueous ammonia</i>
ammonium (NH_4^+)	ammonia produced on warming	–
calcium (Ca^{2+})	white ppt., insoluble in excess	no ppt. or very slight white ppt.
copper (Cu^{2+})	light blue ppt., insoluble in excess	light blue ppt., soluble in excess, giving a dark blue solution
iron(II) (Fe^{2+})	green ppt., insoluble in excess	green ppt., insoluble in excess
iron(III) (Fe^{3+})	red-brown ppt., insoluble in excess	red-brown ppt., insoluble in excess
zinc (Zn^{2+})	white ppt., soluble in excess, giving a colourless solution	white ppt., soluble in excess, giving a colourless solution

Tests for gases

<i>gas</i>	<i>test and test result</i>
ammonia (NH ₃)	turns damp red litmus paper blue
carbon dioxide (CO ₂)	turns limewater milky
chlorine (Cl ₂)	bleaches damp litmus paper
hydrogen (H ₂)	'pops' with a lighted splint
oxygen (O ₂)	relights a glowing splint

Flame tests for metal ions

<i>metal ion</i>	<i>flame colour</i>
lithium (Li ⁺)	red
sodium (Na ⁺)	yellow
potassium (K ⁺)	lilac
copper(II) (Cu ²⁺)	blue-green

Permission to reproduce items where third-party owned material protected by copyright is included has been sought and cleared where possible. Every reasonable effort has been made by the publisher (UCLES) to trace copyright holders, but if any items requiring clearance have unwittingly been included, the publisher will be pleased to make amends at the earliest possible opportunity.

To avoid the issue of disclosure of answer-related information to candidates, all copyright acknowledgements are reproduced online in the Cambridge Assessment International Education Copyright Acknowledgements Booklet. This is produced for each series of examinations and is freely available to download at www.cambridgeinternational.org after the live examination series.

Cambridge Assessment International Education is part of the Cambridge Assessment Group. Cambridge Assessment is the brand name of the University of Cambridge Local Examinations Syndicate (UCLES), which itself is a department of the University of Cambridge.