

UNIVERSITY OF CAMBRIDGE INTERNATIONAL EXAMINATIONS
International General Certificate of Secondary Education

PHYSICS

0625/01

Paper 1 Multiple Choice

May/June 2005

45 minutes

Additional Materials: Multiple Choice Answer Sheet
Soft clean eraser
Soft pencil (type B or HB is recommended)

READ THESE INSTRUCTIONS FIRST

Write in soft pencil.

Do not use staples, paper clips, highlighters, glue or correction fluid.

Write your name, Centre number and candidate number on the Answer Sheet in the spaces provided unless this has been done for you.

There are **forty** questions on this paper. Answer **all** questions.

For each question there are four possible answers **A, B, C** and **D**. Choose the **one** you consider correct and record your choice in **soft pencil** on the separate Answer Sheet.

Read the instructions on the Answer Sheet very carefully.

Each correct answer will score one mark. A mark will not be deducted for a wrong answer.

Any rough working should be done in this booklet.

This document consists of **17** printed pages and **3** blank pages.



- 1 A decorator wishes to calculate the area of a bathroom tile so that he can estimate the amount of adhesive that he needs to buy.

What must he use?

- A a measuring cylinder only
 - B a ruler only
 - C a measuring cylinder and a clock only
 - D a measuring cylinder and a ruler only
- 2 The three balls shown are dropped from a bench.

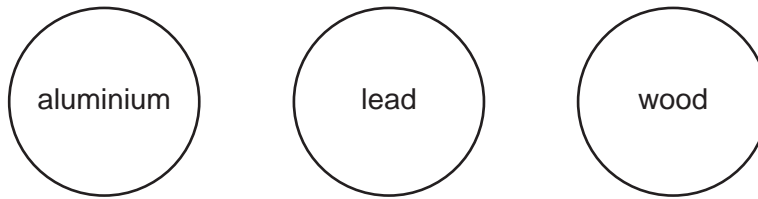

Which balls have the same acceleration?

- A aluminium and lead only
 - B aluminium and wood only
 - C lead and wood only
 - D aluminium, lead and wood
- 3 A car accelerates from traffic lights. The graph shows how the car's speed changes with time.

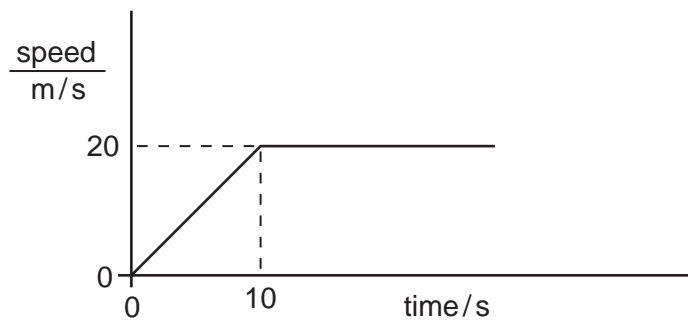

How far does the car travel before it reaches a steady speed?

- A 10 m
- B 20 m
- C 100 m
- D 200 m

- 4 Which statement is correct?
- A The mass of a bottle of water at the North Pole is different from its mass at the Equator.
 - B The mass of a bottle of water is measured in newtons.
 - C The weight of a bottle of water and its mass are the same thing.
 - D The weight of a bottle of water is one of the forces acting on it.
- 5 Two blocks X and Y are placed on a beam as shown. The beam balances on a pivot at its centre.

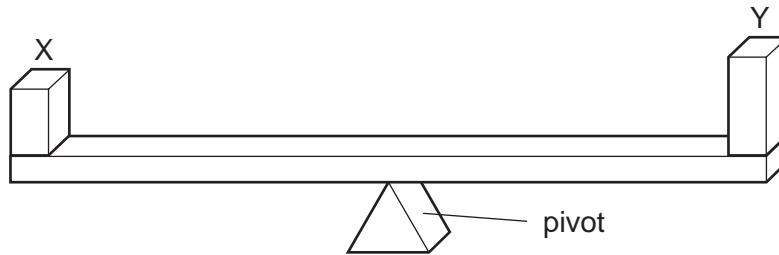

What does this show about X and Y?

- A They have the same mass and the same density.
 - B They have the same mass and the same weight.
 - C They have the same volume and the same density.
 - D They have the same volume and the same weight.
- 6 The masses of a measuring cylinder before and after pouring some liquid into it are shown in the diagram.

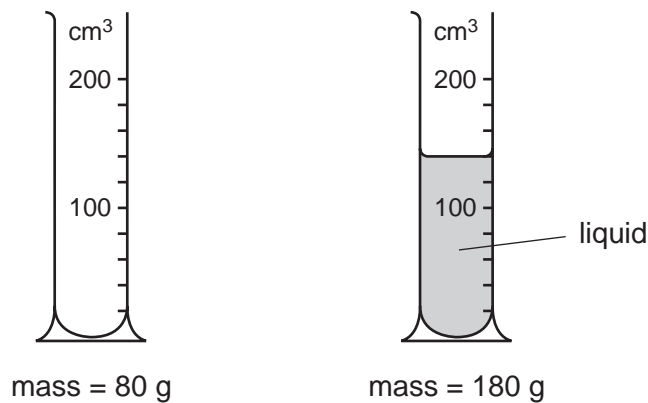

What is the density of the liquid?

- A $\frac{100}{120} \text{ g/cm}^3$
- B $\frac{100}{140} \text{ g/cm}^3$
- C $\frac{180}{120} \text{ g/cm}^3$
- D $\frac{180}{140} \text{ g/cm}^3$

- 7 A girl and a boy are pulling in opposite directions on a rope. The forces acting on the rope are shown in the diagram.

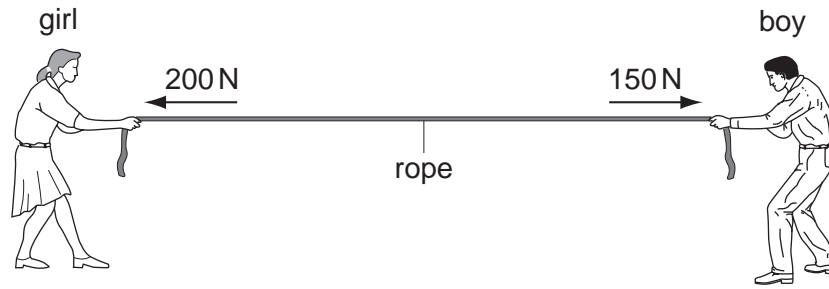

Which single force has the same effect as the two forces shown?

- A 50 N acting towards the girl
 - B 350 N acting towards the girl
 - C 50 N acting towards the boy
 - D 350 N acting towards the boy
- 8 Objects with different masses are hung on a 10 cm spring. The diagram shows how much the spring stretches.

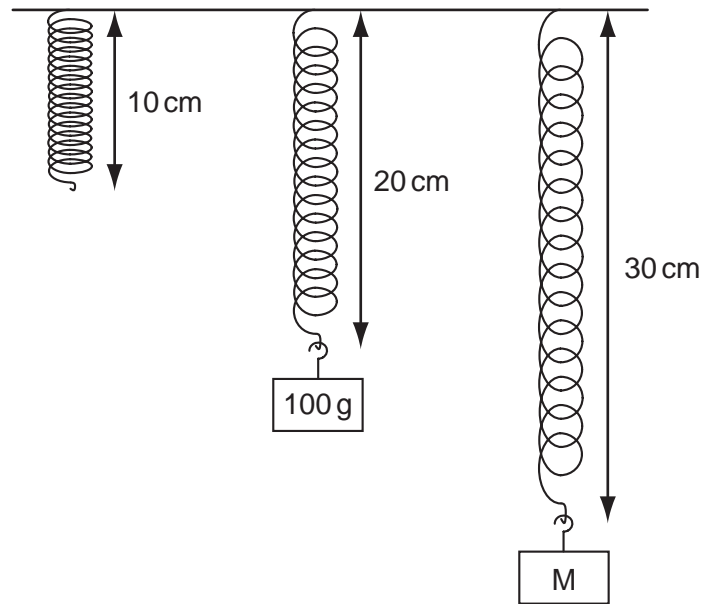

The extension of the spring is directly proportional to the mass hung on it.

What is the mass of object M?

- A 110 g
- B 150 g
- C 200 g
- D 300 g

9 What is designed to change electrical energy into kinetic energy?

- A capacitor
- B generator
- C motor
- D transformer

10 A power station uses nuclear fission to obtain energy.

In this process, nuclear energy is **first** changed into

- A chemical energy.
- B electrical energy.
- C gravitational energy.
- D internal energy.

11 A ball is released from rest and rolls down a track from the position shown.

What is the furthest position the ball could reach?

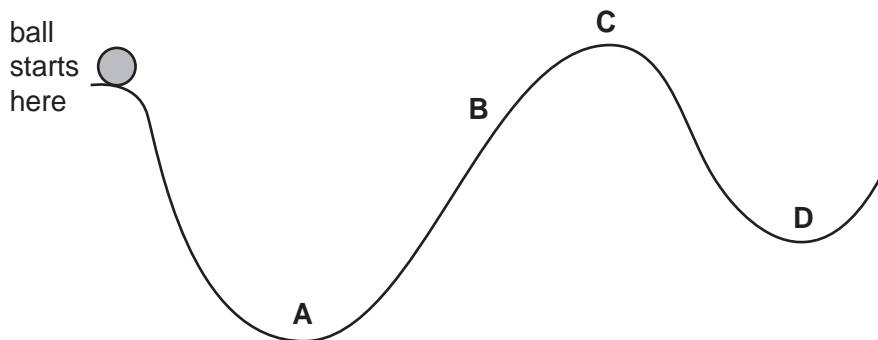

12 A water manometer is used to measure the pressure of a gas supply to a house. The reading is h cm of water.

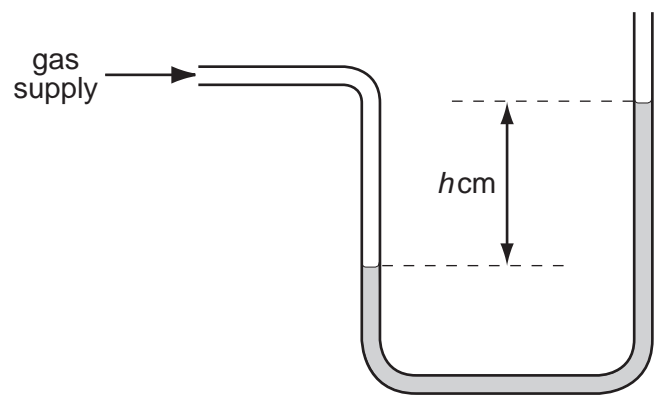

Why is it better to use water rather than mercury in this manometer?

- A h would be too large if mercury were used.
- B h would be too small if mercury were used.
- C The tube would need to be narrower if mercury were used.
- D The tube would need to be wider if mercury were used.

13 A farmer has two carts. The carts have the same weight, but one has four narrow wheels and the other has four wide wheels.

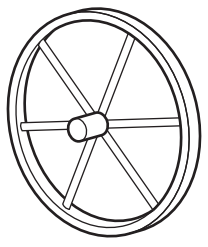

narrow wheel

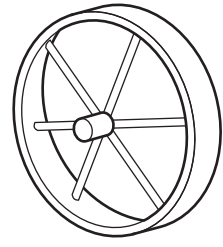

wide wheel

In rainy weather, which cart sinks **less** into soft ground, and why?

	cart wheels	why
A	narrow	greater pressure on the ground
B	narrow	less pressure on the ground
C	wide	greater pressure on the ground
D	wide	less pressure on the ground

- 14 Viewed through a microscope, very small particles can be seen moving with Brownian motion.

Which line in the table is correct?

	type of motion of particles	particles are suspended in
A	vibration	a liquid or a gas
B	vibration	a solid, a liquid or a gas
C	random	a liquid or a gas
D	random	a solid, a liquid or a gas

- 15 A measured mass of gas is placed in a cylinder at atmospheric pressure and is then slowly compressed.

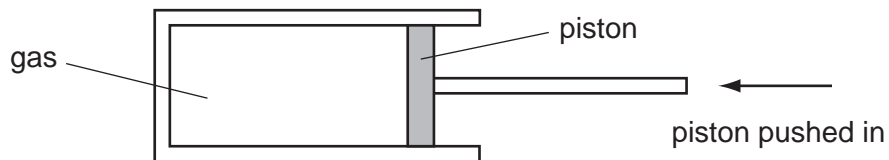

The temperature of the gas does not change.

What happens to the pressure of the gas?

- A** It drops to zero.
 - B** It decreases, but not to zero.
 - C** It stays the same.
 - D** It increases.
- 16 The graph shows the change in temperature of a material as it is heated.

Which part on the graph shows when the material is boiling?

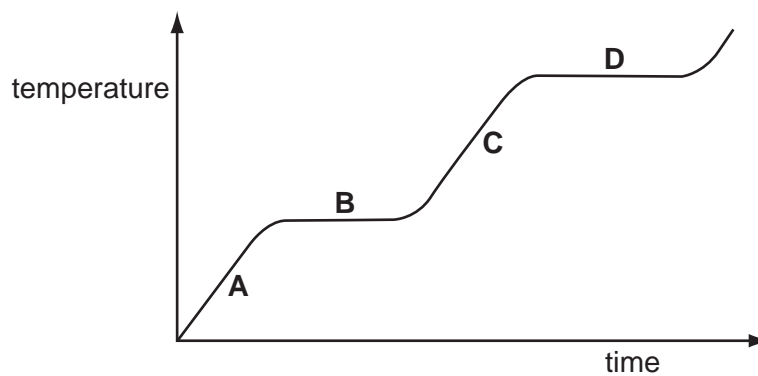

17 An experiment is set up as shown.

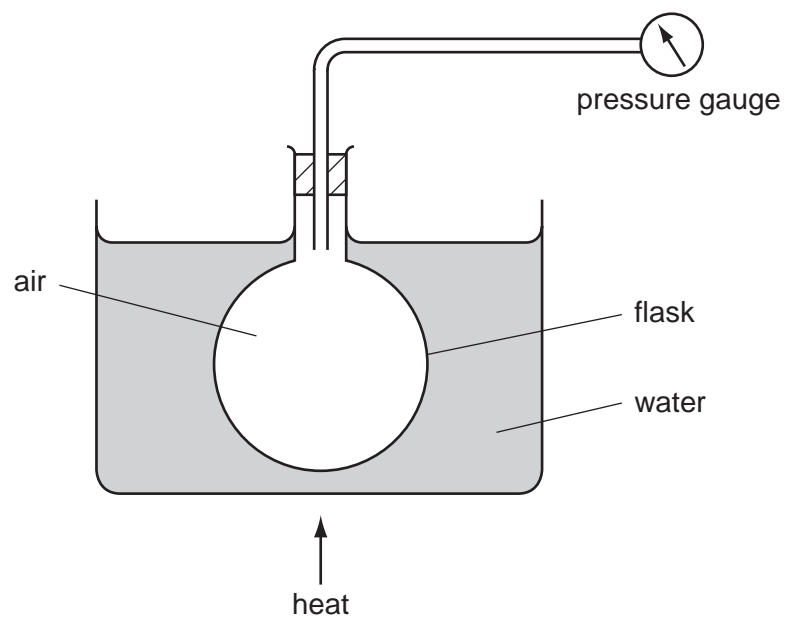

What does the pressure gauge show as the air in the flask becomes hotter?

- A a steady pressure
- B a decrease in pressure
- C an increase in pressure
- D an increase and then a decrease in pressure

18 An iron bar is held with one end in a fire. The other end soon becomes too hot to hold.

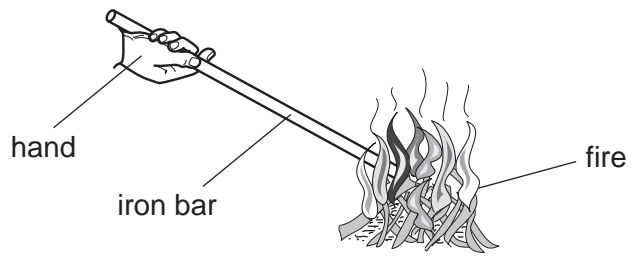

How has the heat travelled along the iron bar?

- A by conduction
- B by convection
- C by expansion
- D by radiation

19 The diagram shows a block of ice placed in a warm room.

At which point is the temperature the **lowest**?

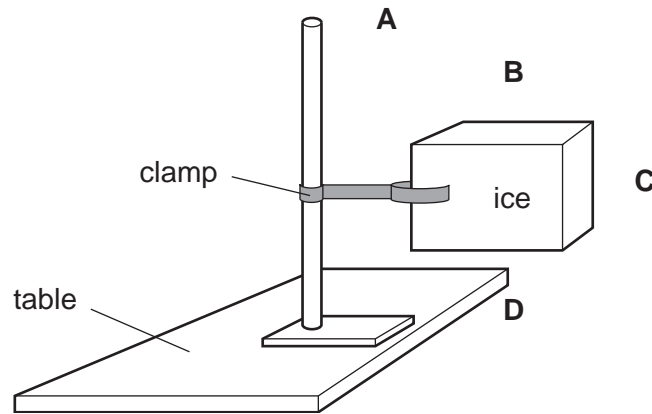

20 The drawing shows a wave.

Which labelled distance is the wavelength?

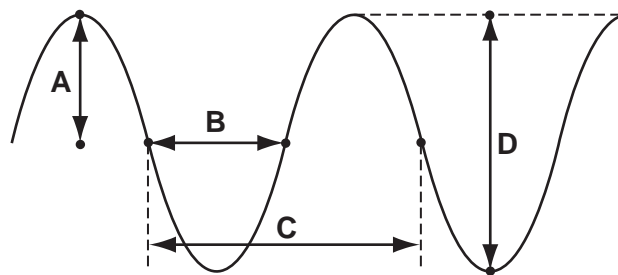

21 Radio waves are received at a house at the bottom of a hill.

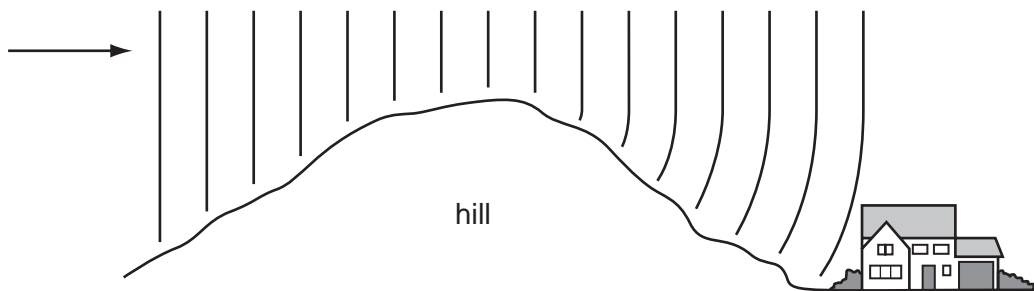

The waves reach the house because the hill has caused them to be

- A diffracted.
- B radiated.
- C reflected.
- D refracted.

22 Which diagram correctly shows a ray of light passing through a rectangular glass block?

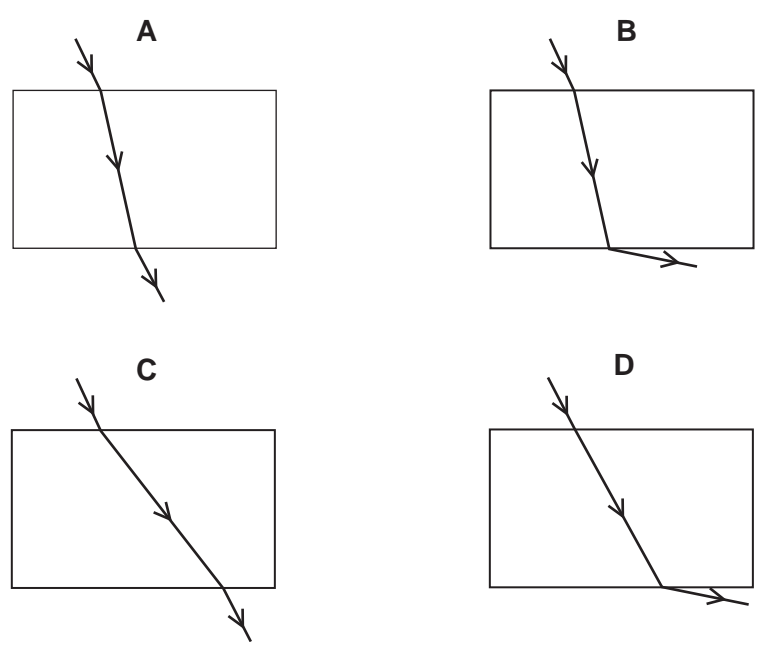

23 The ray diagram shows how an image is formed by a converging lens.

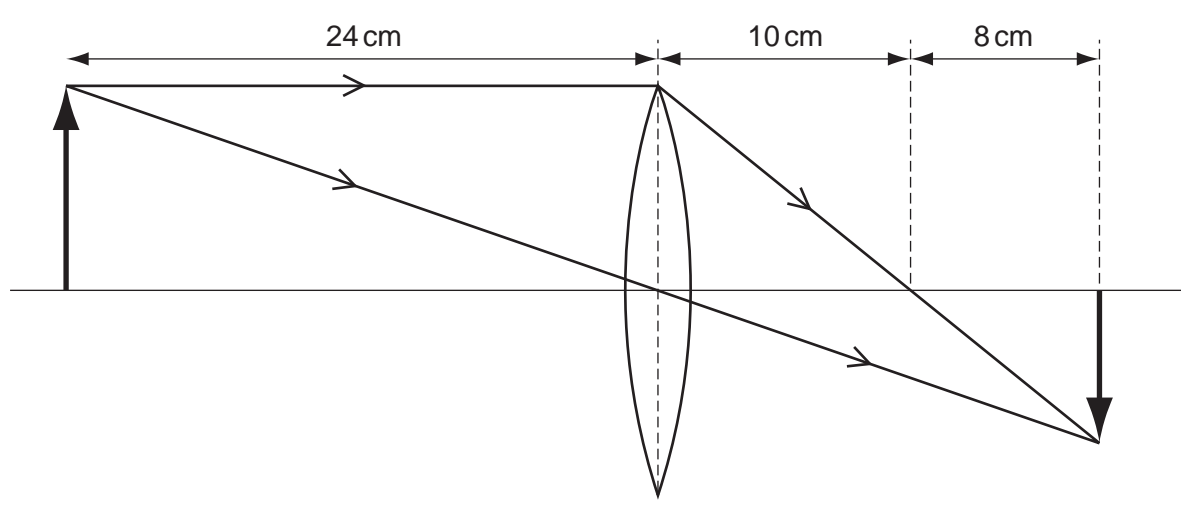

What is the focal length of this lens?

- A 8 cm
- B 10 cm
- C 18 cm
- D 24 cm

- 24 A fire alarm is not loud enough. An engineer adjusts it so that it produces a note of the same frequency which is louder.

What effect does this have on the amplitude and on the frequency of the sound?

	amplitude	frequency
A	larger	larger
B	larger	same
C	same	larger
D	same	same

- 25 To estimate the width of a valley, a climber starts a stopwatch as he shouts. He hears an echo from the opposite side of the valley after 1.0 s.

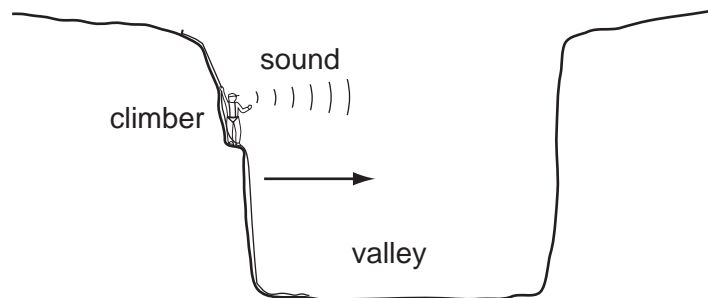

The sound travels at 340 m/s.







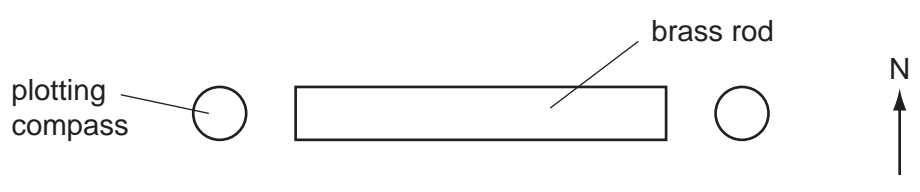





What is the width of the valley?

- A** 85 m **B** 170 m **C** 340 m **D** 680 m
- 26 Which material is used for the core of an electromagnet?
- A** aluminium
B copper
C iron
D steel

27 A brass rod is positioned in an east-west direction and a plotting compass is placed at each end of the rod.



Which diagram shows the positions of the needles of the plotting compasses?

- A   
- B   
- C   
- D   

28 How many of the following materials conduct electricity?

- aluminium
- silver
- iron
- plastic

- A 1
- B 2
- C 3
- D 4

29 In which circuit does the voltmeter read the potential difference across the lamp?

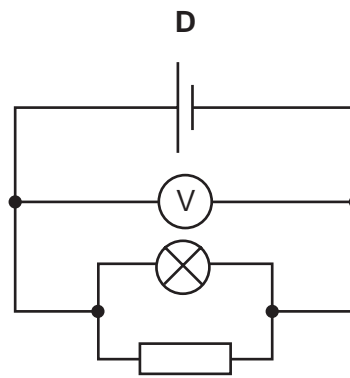
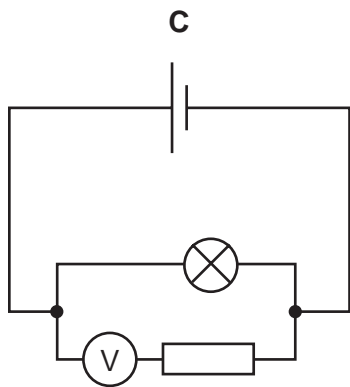
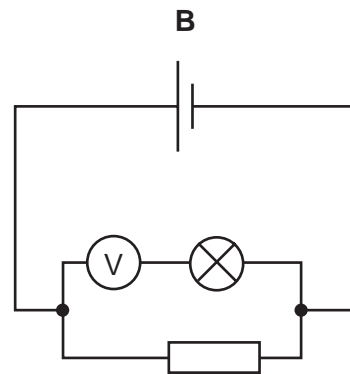
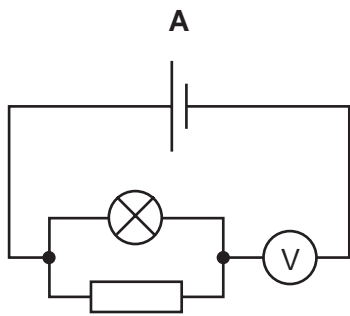

30 In the circuit below, X and Y are identical 6 V lamps.

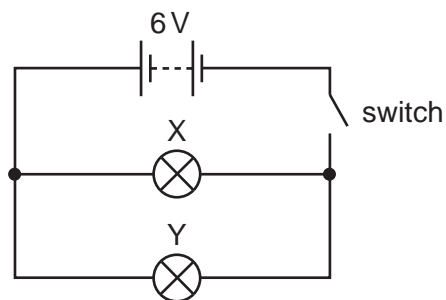

What happens when the switch is closed?

- A** X lights more brightly than Y.
- B** Y lights more brightly than X.
- C** X and Y light with equal brightness.
- D** Neither X nor Y light.

31 The diagram shows a circuit with three ammeters, X, Y and Z.

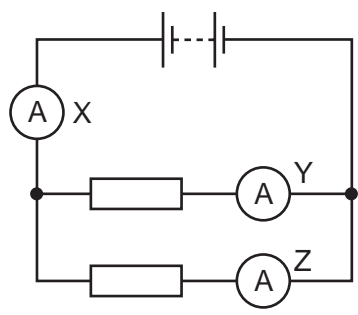

Which set of readings is possible?

	X	Y	Z
A	2A	3A	5A
B	3A	2A	5A
C	3A	3A	3A
D	5A	2A	3A

32 A lamp is to be connected in a circuit so that the p.d. across it can be varied from 0 to 6V.

Which circuit would be most suitable?

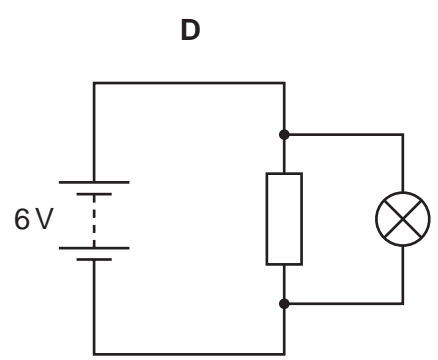
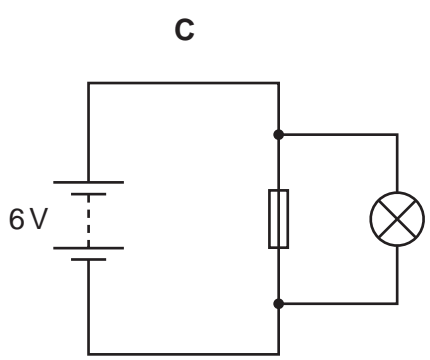
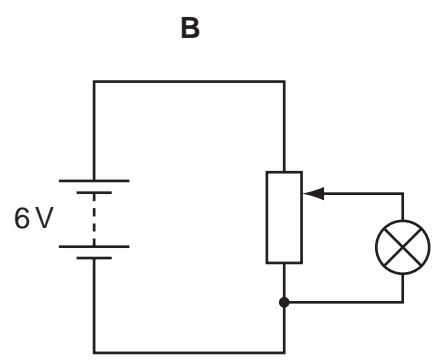
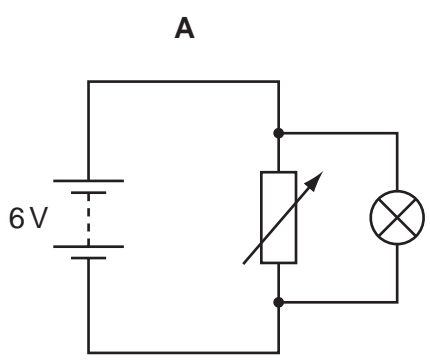

33 A student makes the circuit shown.

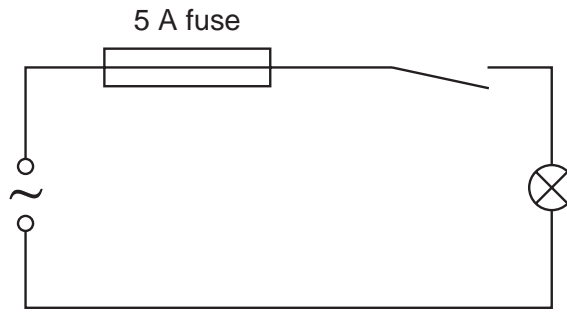

The fuse has blown and stopped the current.

What could have caused this?

- A The current rating of the fuse was too high.
- B The current was too large.
- C The lamp was loose.
- D The voltage was too small.

34 Which graph shows the output voltage from a simple a.c. generator?

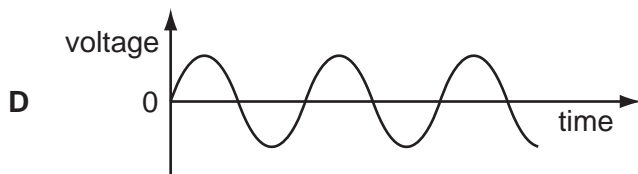
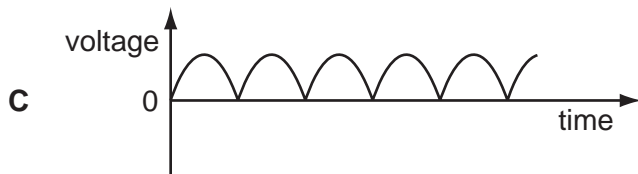
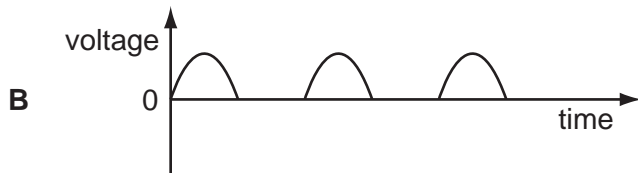
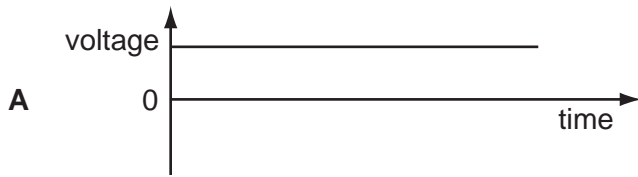

35 A transformer has 50 turns on its primary coil and 100 turns on its secondary coil. An a.c. supply of 25.0V is connected across the primary coil.

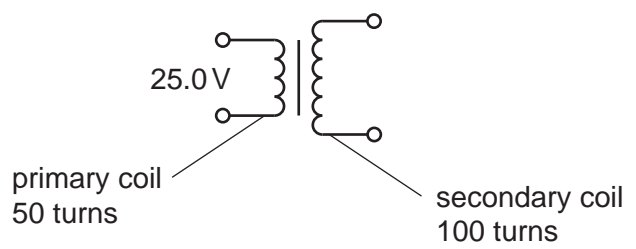

What is the voltage across the secondary coil?

- A 12.5V
- B 50.0V
- C 175V
- D 200V

36 Two circuits are set up as shown. The iron rods are placed close together, and are free to move.

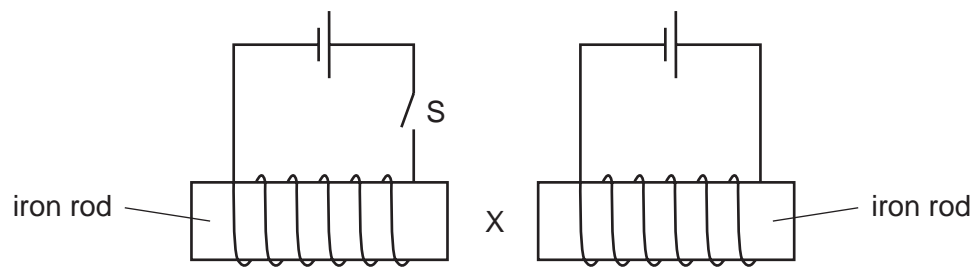

What happens to the size of the gap at X when switch S is closed?

- A It decreases.
- B It decreases then increases.
- C It increases.
- D It does not change.

37 The diagram shows a simple cathode-ray tube.

Which part emits the electrons?

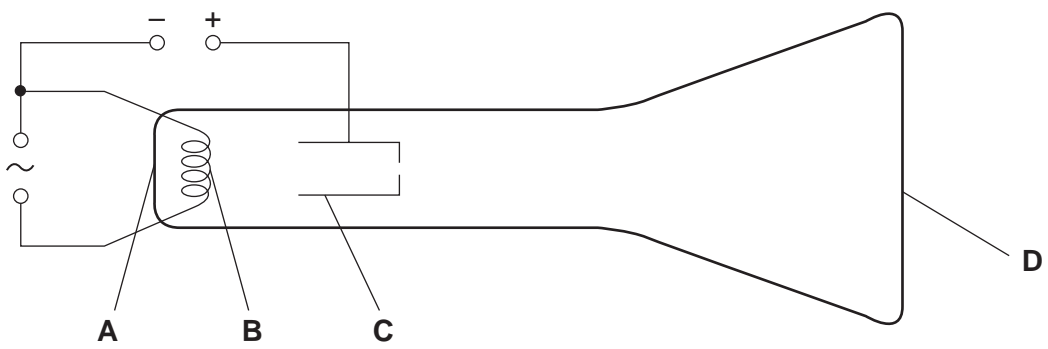

38 Which type of radiation has the greatest ionising effect?

- A α -particles
- B β -particles
- C γ -rays
- D all have the same ionising effect

39 A powder contains 400 mg of a radioactive material that emits α -particles.

The half-life of the material is 5 days.

What mass of that material remains after 10 days?

- A 0 mg B 40 mg C 100 mg D 200 mg

40 In the symbol below, A is the nucleon number and Z is the proton number.



What is represented by the symbol?

- A an electron
- B a neutron
- C a nuclide
- D an X-ray

