

UNIVERSITY OF CAMBRIDGE INTERNATIONAL EXAMINATIONS
International General Certificate of Secondary Education

PHYSICS

0625/05

Paper 5 Practical Test

May/June 2006

CONFIDENTIAL INSTRUCTIONS

Great care should be taken to ensure that any confidential information given does not reach the candidates either directly or indirectly.

If you have any problems or queries regarding these Instructions, please contact CIE
by e-mail: International@cie.org.uk,
by phone: +44 1223 553554,
by fax: +44 1223 553558,
stating the Centre number, the nature of the query and the syllabus number quoted above.

This document consists of **8** printed pages.

Instructions for preparing apparatus

The Supervisor is **not** allowed to consult the Question Paper before the examination. This should, as part of the preparation of the examination requirements, test the apparatus in order to ensure that it is satisfactory.

The Supervisor is asked to give (and attach to the Report form printed on pages 7 and 8) a *brief* description of the apparatus supplied, mentioning any points that are likely to be of importance to the Examiner in marking the answers. The Supervisor should also report any assistance given to candidates. All reports should be signed by the Supervisor and by the person responsible for preparing the apparatus.

In addition to the usual equipment of a physics laboratory, each candidate will require the apparatus specified in these Instructions. If a candidate breaks any of the apparatus, or loses any of the material supplied, the matter should be rectified and a note made in the Report.

Number of sets of apparatus

As a *minimum*, the number of sets of apparatus provided should be $N/4$, where N is the number of candidates (per session). A few spare sets should, preferably, be available to avoid any candidate being delayed when moving to another question.

Centres may find it more convenient and easier to administer if $N/3$ sets (plus one or two 'spares') of apparatus are provided.

The order in which a given candidate attempts the four questions is immaterial.

Assistance to Candidates

The purpose of the Practical Physics test is to find out whether the candidates can carry out simple practical work themselves. The Examiners are aware that candidates may sometimes be unable to show their practical ability through failure to understand some point in the theory of the experiment. If an Examiner were present in the laboratory, he/she would be willing to give a hint to enable such a candidate to get on with an experiment. In order to overcome this difficulty, the Supervisor is asked to co-operate with the Examiners to the extent of being ready to give (or allow the Physics teacher to give) a hint to a candidate who is unable to proceed.

The following regulations must be strictly adhered to.

- (i) No hint may be announced to the candidates as a whole.
- (ii) A candidate who is unable to proceed and requires assistance must come up to the Supervisor and state the difficulty. Candidates should be told that the Examiners will be informed of any assistance given in this way.
- (iii) A report must be made of any assistance given to the candidate, with the name and index number of the candidate.

It is suggested that the following announcement be made to the candidates.

'The Examiners do not want you to waste time through inability to get on with an experiment. Any candidate, therefore, who is unable to get on with the experiment after spending five minutes at it may come to me and ask for help. I shall report to the Examiners any help given in this way, and some marks may be lost for the help given. You may ask me for additional apparatus which you think would improve the accuracy of your experiments, and you should say, on your script, how you use any such

Question 1

Items to be supplied by the Centre (per set of apparatus unless otherwise specified)

300 mm or 500 mm rule

Balance capable of measuring mass to 0.1 g.

Stack of 10 cards each 9.5 cm (± 0.1 cm) x 5.5 cm (± 0.1 cm).

Notes

1. The cards in each stack should be made from the same type of card. The stiffening card from an A4 pad of paper is suitable. Corrugated card should not be used.
2. It is not necessary to supply a balance for each set of apparatus but candidates must have easy access to a nearby balance.
3. At the changeover, check that all ten pieces of card are in the stack.

Information required by examiners

None.

Question 2**Items to be supplied by the Centre (per set of apparatus unless otherwise specified)**

Power source of approximately 1.5–2.0 V. Where candidates are supplied with a power source with variable output voltage, the voltage setting should be set by the Supervisor and fixed (e.g. taped).

Voltmeter capable of measuring the supply p.d. with a minimum precision of 0.1 V.

Ammeter capable of reading up to 1.0 A with a minimum precision of 0.05 A.

2 similar lamps in suitable holders: any low voltage lamps will suffice, provided that they glow when connected in series or parallel with the power supply.

Switch.

Sufficient connecting leads to construct the circuit shown in Fig. 2.1 plus two additional leads.

Notes

1. The components should be connected by the Supervisor as shown in Fig. 2.1.

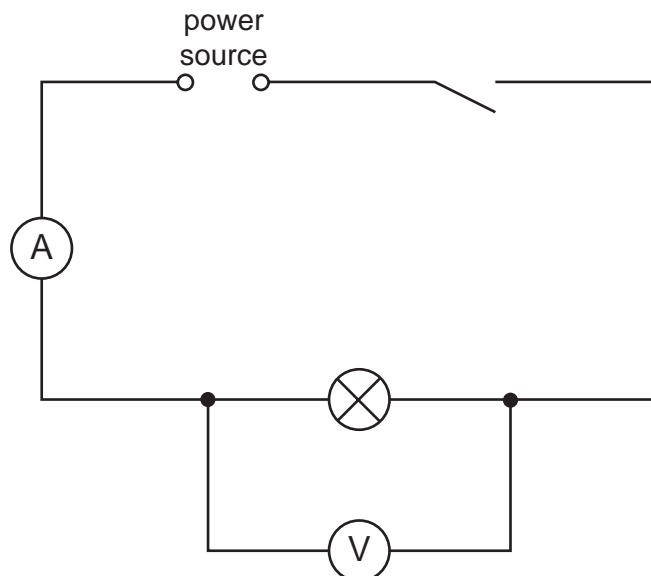

Fig. 2.1

2. It should be possible for candidates to connect the second lamp in parallel with the first.
3. If cells are used as the power source, they must remain adequately charged throughout the examination.
4. At the changeover, reconnect the circuit as shown in Fig. 2.1. If cells are used, check that they are adequately charged.

Information required by examiners

None

Question 3**Items to be supplied by the Centre (per set of apparatus unless otherwise specified)**

Metre rule with a small hole drilled centrally at the 1.0 cm mark. The hole must be large enough to accept the pivot so that the rule can pivot freely.

Optics pin, thin round nail or similar to act as a pivot for the metre rule.

Two clamps, two stands and two bosses.

Newton meter 0–1.0 N.

Loop of string (sufficiently large to attach the metre rule to the newton meter, see Fig. 3.1).

300 mm or 500 mm rule.

Notes

1. The apparatus is to be set up by the Supervisor as shown in Fig. 3.1.

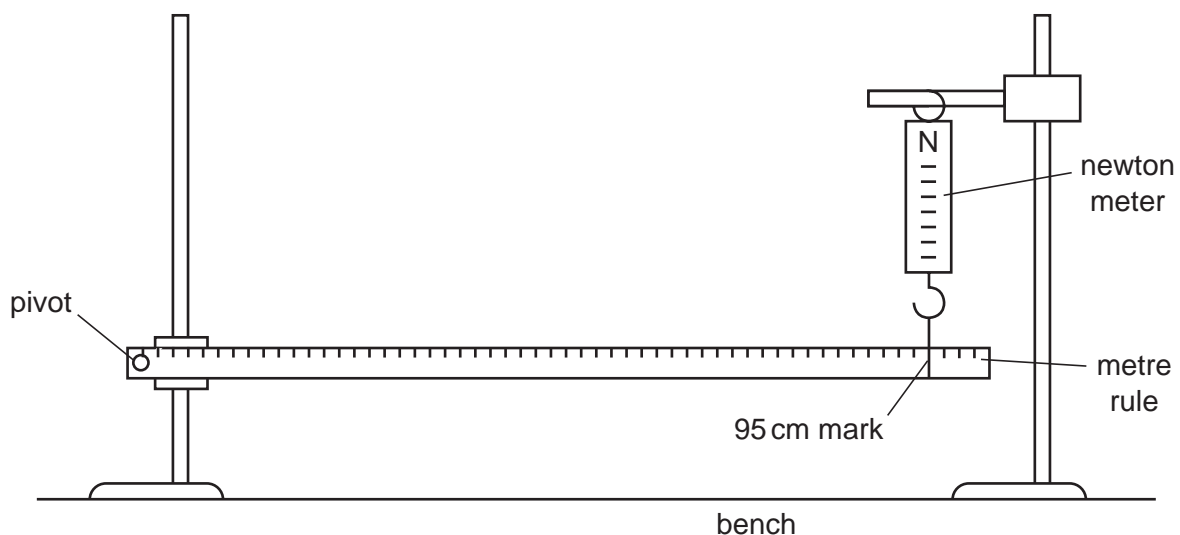
**Fig. 3.1**

2. The optics pin or nail may be held in the clamp either in a cork or between two small pieces of wood.
3. If the mass of the metre rule is greater than 140 g, then a 0–2.0 N newton meter should be used.
4. At the changeover, check that the apparatus is set up as shown in Fig. 3.1.

Information required by examiners

None.

Question 4**Items to be supplied by the Centre (per set of apparatus unless otherwise specified).**

Sheet of plain A4 size paper with a hole in one corner so that it can be tied into the Answer Booklet (one sheet per candidate is required).

Rectangular, transparent glass or Perspex block 10 cm × 6 cm × 1.5 cm or similar size.

4 optics pins.

Pin board (e.g. a cork mat), A4 size or larger.

Protractor.

50 cm or 30 cm rule, graduated in mm.

String to tie the plain sheet of A4 size paper into the Answer Booklet.

Notes

1. Some spare sheets of plain A4 size paper should be available.
2. At the changeover, supply a new sheet of plain A4 size paper.

Information required by examiners

None.

This form must be completed and returned with the scripts.

REPORT ON PRACTICAL PHYSICS

(IGCSE MAY/JUNE 2006)

General

The Supervisor is invited to give details of any difficulties experienced by particular candidates giving their names and candidate numbers. These should include reference to:

- (a) difficulties due to faulty apparatus;
- (b) accidents to apparatus or materials;
- (c) any other information that is likely to assist the Examiner, especially if this cannot be discovered in the scripts;
- (d) any help given to a candidate.

Information required

A plan of workbenches, giving details by candidate number of the places occupied by the candidates for each experiment for each session, must be enclosed with the Answer Booklets.



Information required (cont.)

A list by name and candidate number of candidates requiring help, with details of the help provided.

CENTRE NO.

NAME OF CENTRE

Declaration (to be signed by the Supervisor and the person responsible for preparing the apparatus)

The preparation of the practical examination has been carried out so as to maintain fully the security of the examination.

SIGNED
Supervisor

SIGNED
Person responsible for preparing the apparatus

