



UNIVERSITY OF CAMBRIDGE INTERNATIONAL EXAMINATIONS
International General Certificate of Secondary Education

PHYSICS

0625/11

Paper 1 Multiple Choice

October/November 2013

45 minutes

Additional Materials: Multiple Choice Answer Sheet
 Soft clean eraser
 Soft pencil (type B or HB recommended)

READ THESE INSTRUCTIONS FIRST

Write in soft pencil.

Do not use staples, paper clips, highlighters, glue or correction fluid.

Write your name, Centre number and candidate number on the Answer Sheet in the spaces provided unless this has been done for you.

DO NOT WRITE IN ANY BARCODES.

There are **forty** questions on this paper. Answer **all** questions. For each question there are four possible answers **A, B, C** and **D**.

Choose the **one** you consider correct and record your choice in **soft pencil** on the separate Answer Sheet.

Read the instructions on the Answer Sheet very carefully.

Each correct answer will score one mark. A mark will not be deducted for a wrong answer.

Any rough working should be done in this booklet.

Electronic calculators may be used.

This document consists of **16** printed pages.



1 A student uses a ruler to measure the length and the width of a small rectangular metal plate.

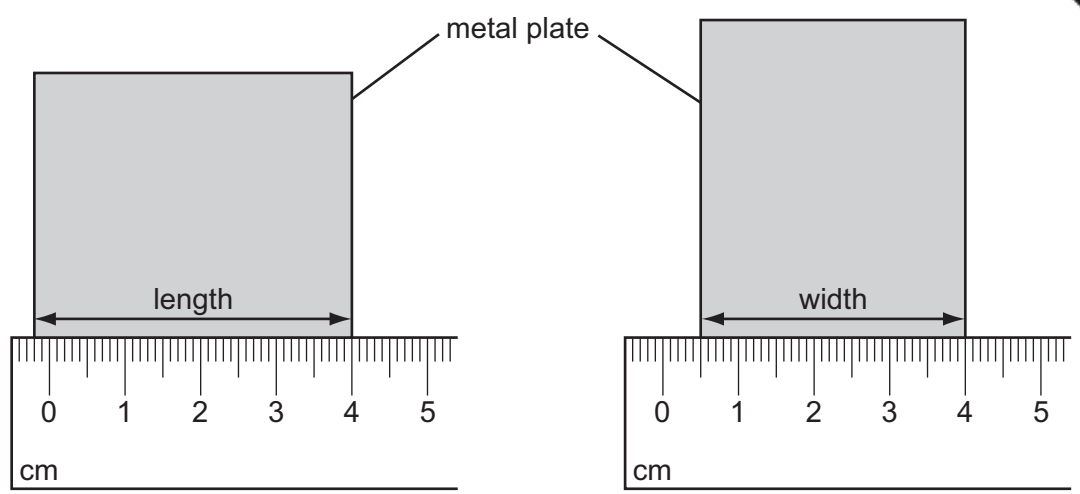

What is the area of the plate?

- A 14.0 cm²
- B 14.7 cm²
- C 16.0 cm²
- D 16.8 cm²

2 The diagram shows the speed/time graph for a train as it travels along a track.

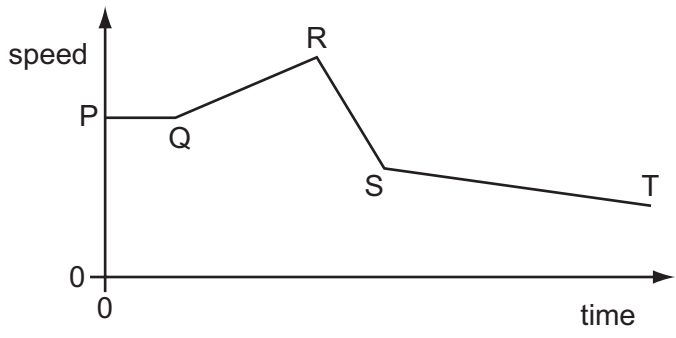

For which part of the graph is the train's speed changing at the greatest rate?

- A PQ
- B QR
- C RS
- D ST

3 A small steel ball is dropped from a low balcony.

Ignoring air resistance, which statement describes its motion?

- A It falls with constant acceleration.
- B It falls with constant speed.
- C It falls with decreasing speed.
- D It falls with increasing acceleration.

4 Which is the unit for force and which is the unit for weight?

| | force | weight |
|----------|-------|--------|
| A | kg | kg |
| B | kg | N |
| C | N | kg |
| D | N | N |

5 A cup contains hot liquid.

Some of the liquid evaporates.

What happens to the mass and to the weight of the liquid in the cup?

| | mass | weight |
|----------|----------------|----------------|
| A | decreases | decreases |
| B | decreases | stays the same |
| C | stays the same | decreases |
| D | stays the same | stays the same |

6 Four rectangular blocks, P, Q, R and S are shown. Each block is labelled with its size and its mass.

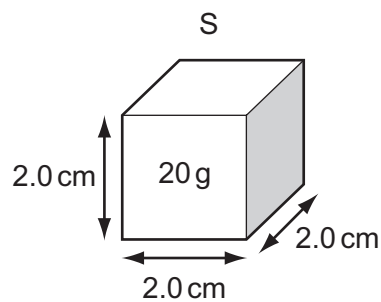
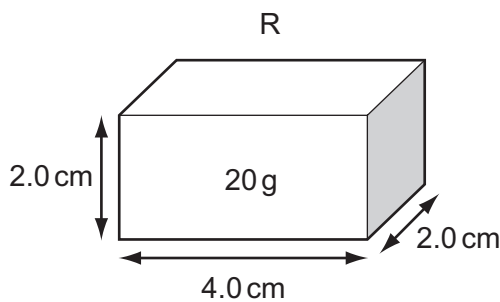
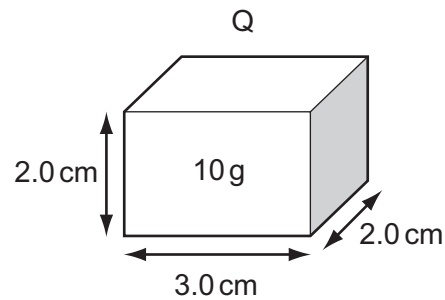
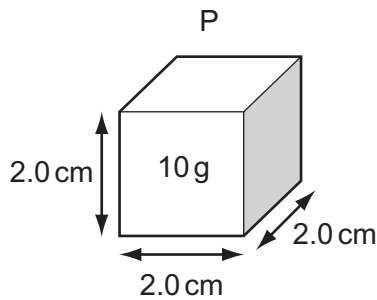

Which two blocks have the same density?

- A** P and Q **B** P and R **C** Q and R **D** R and S

- 7 A force acting on an object causes some properties of the object to change.

Which list contains **only** properties that can be changed by the action of the force?

- A mass, motion and shape
- B mass, motion and size
- C mass, shape and size
- D motion, shape and size

- 8 A box is being moved by a fork-lift truck. The total weight of the box is 3000 N.

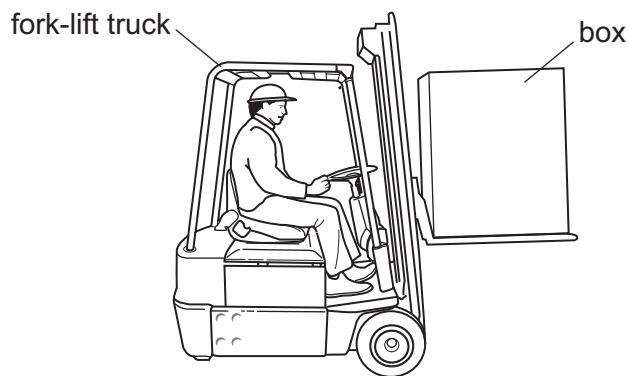

The force exerted by the fork-lift truck on the box is 3500 N upwards.

What is the resultant force on the box?

- A 500 N downwards
 - B 500 N upwards
 - C 6500 N downwards
 - D 6500 N upwards
- 9 Some energy sources are reliably available at all times, and some are not.

Which row shows three sources all in their correct columns?

| | available at all times | not available at all times |
|---|-----------------------------|-----------------------------|
| A | geothermal | nuclear fission, solar |
| B | geothermal, nuclear fission | solar |
| C | solar, nuclear fission | geothermal |
| D | solar | nuclear fission, geothermal |

10 A woman in a factory has to lift a box on to a shelf.

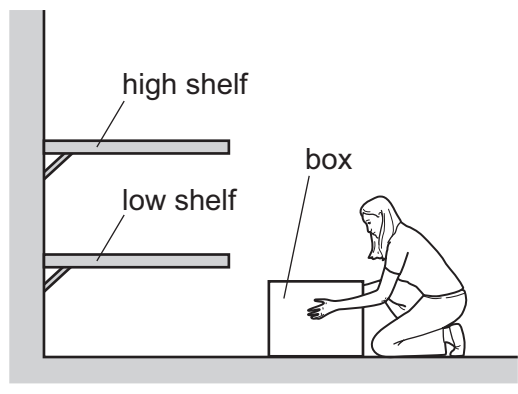

Which action involves the woman in doing the **least** amount of work?

- A lifting the box quickly to the high shelf
- B lifting the box slowly to the high shelf
- C lifting the box to the low shelf first then lifting it to the high shelf
- D lifting the box to the low shelf instead of to the high shelf

11 A drawing pin (thumb tack) has a sharp point and a flat end.

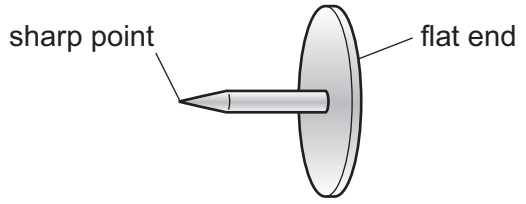

The pin is pushed into a wooden board.

How do the pressure and the force at the sharp point compare with the pressure and the force at the flat end?

| | force at the sharp point | pressure at the sharp point |
|----------|------------------------------|------------------------------|
| A | greater than at the flat end | greater than at the flat end |
| B | greater than at the flat end | less than at the flat end |
| C | the same as at the flat end | greater than at the flat end |
| D | the same as at the flat end | less than at the flat end |

12 The diagrams show four divers at the bottom of four different swimming pools.

Two swimming pools contain fresh water and two contain salt water. Fresh water is less dense than salt water.

Which diver feels the least pressure from the water?

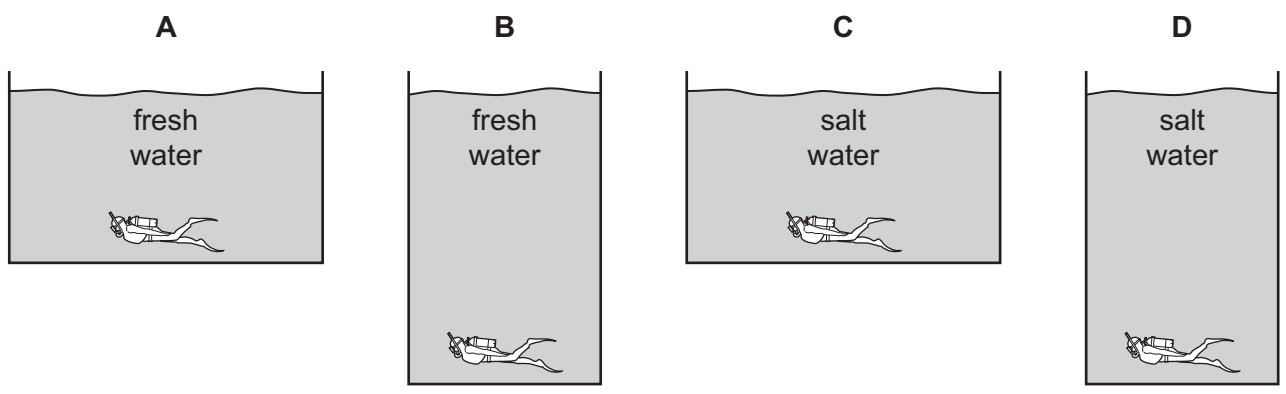

13 The diagram shows a sealed jar containing a gas.

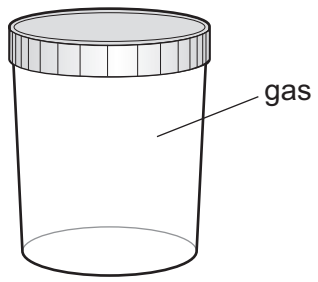

Which statement about the gas in the jar is correct?

- A The gas molecules collide with the inside of the jar more often as the temperature increases.
- B The gas molecules move more slowly as the temperature increases.
- C The pressure of the gas decreases as the temperature increases.
- D The pressure of the gas is higher at the top of the jar than at the bottom of the jar.

14 A block of ice cream is prevented from melting by wrapping it in newspaper soaked in water. The water evaporates from the newspaper.

Which molecules escape from the water and what happens to the average speed of the water molecules that remain in the newspaper?

| | escaping molecules | average speed of the remaining water molecules |
|---|-------------------------|--|
| A | the less energetic ones | decreases |
| B | the less energetic ones | increases |
| C | the more energetic ones | decreases |
| D | the more energetic ones | increases |

- 15 Equal masses of two different liquids are heated using the same heater. The graph shows how the temperature of each liquid changes with time.

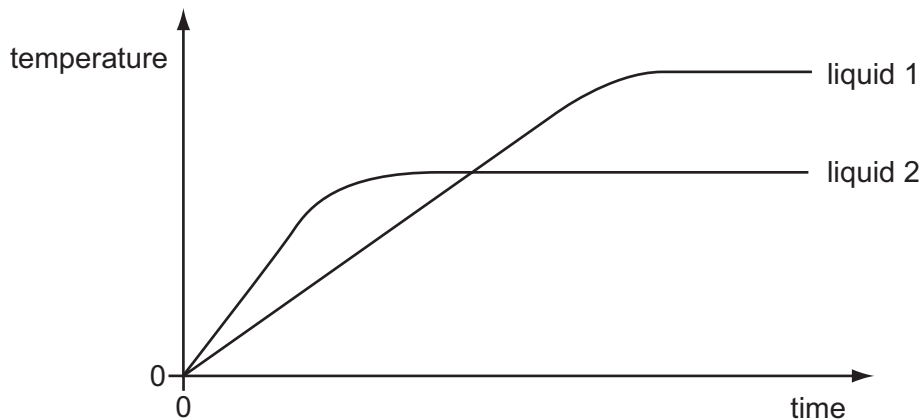

What does the graph tell us about the liquids?

- A Liquid 1 has a higher melting point than liquid 2.
 - B Liquid 1 has a higher boiling point than liquid 2.
 - C Liquid 1 starts to melt sooner than liquid 2.
 - D Liquid 1 starts to boil sooner than liquid 2.
- 16 A wooden wheel can be strengthened by putting a tight circle of iron around it.

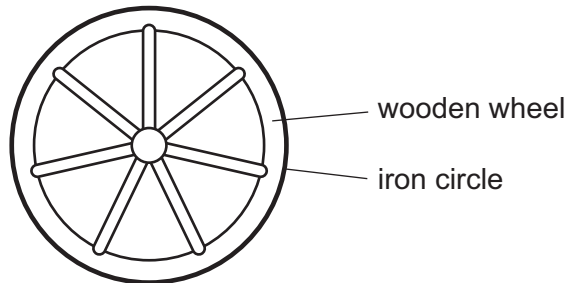

Which action would make it easier to fit the circle over the wood?

- A cooling the iron circle
- B heating the iron circle
- C heating the wooden wheel and cooling the iron circle
- D heating the wooden wheel but not heating or cooling the iron circle

17 A man goes into a cold room and switches on a heater. The man then stands one metre from the heater. He feels warmer almost immediately.

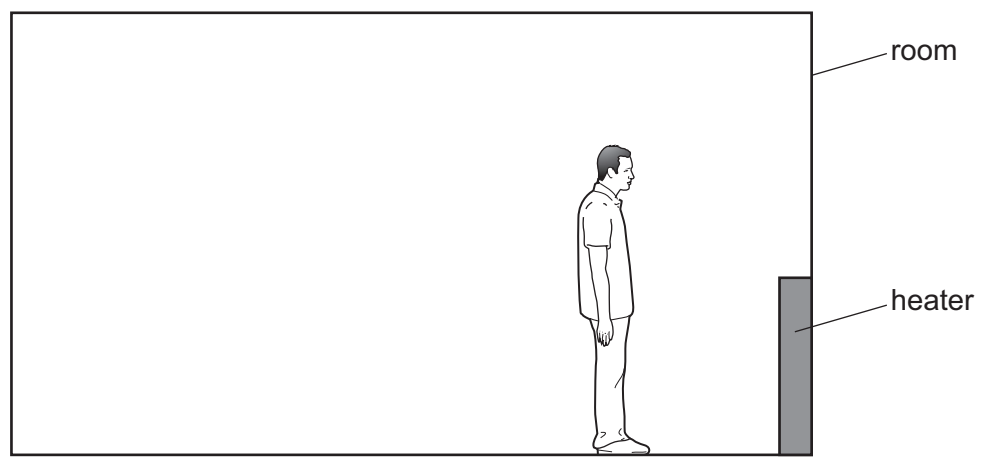

How is thermal energy transferred from the heater to the man so quickly?

- A by conduction, convection and radiation
- B by conduction only
- C by convection only
- D by radiation only

18 A rod is made half of glass and half of copper. Four pins, A, B, C and D are attached to the rod by wax. The rod is heated in the centre as shown.

Which pin falls off first?

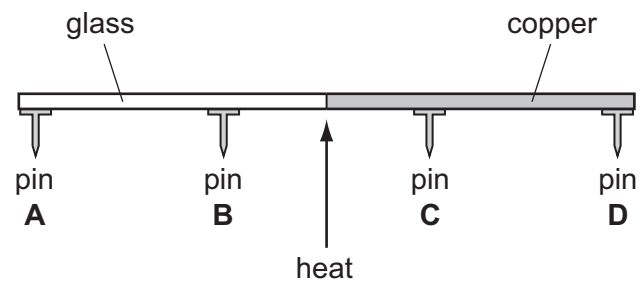

19 Which row shows an example of a transverse wave and an example of a longitudinal wave?

| | transverse | longitudinal |
|---|------------|--------------|
| A | light | radio |
| B | radio | sound |
| C | sound | water |
| D | water | light |

20 A boy throws a small stone into a pond. Waves spread out from where the stone hit and travel to the side of the pond.

The boy notices that eight waves reach the side of the pond in a time of 5.0 s.

What is the frequency of the waves?

- A 0.20 Hz B 0.63 Hz C 1.6 Hz D 40 Hz

21 The table gives common uses for three types of electromagnetic wave.

Which row correctly identifies the waves?

| | satellite television | terrestrial television (not satellite) | television remote controllers |
|----------|----------------------|--|-------------------------------|
| A | infra-red waves | microwaves | radio waves |
| B | microwaves | radio waves | infra-red waves |
| C | radio waves | infra-red waves | microwaves |
| D | radio waves | microwaves | infra-red waves |

22 The diagram shows a ray of light passing through a semicircular glass block into air.

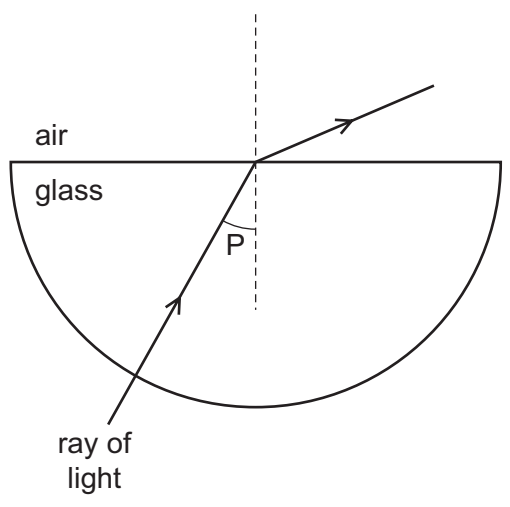

Which row gives the correct name for angle P and states how angle P compares with the critical angle?

| | name of angle P | angle P compared with the critical angle |
|----------|---------------------|--|
| A | angle of incidence | larger than the critical angle |
| B | angle of incidence | smaller than the critical angle |
| C | angle of refraction | larger than the critical angle |
| D | angle of refraction | smaller than the critical angle |

23 Which diagram shows how an image of an object is formed on a screen by a converg

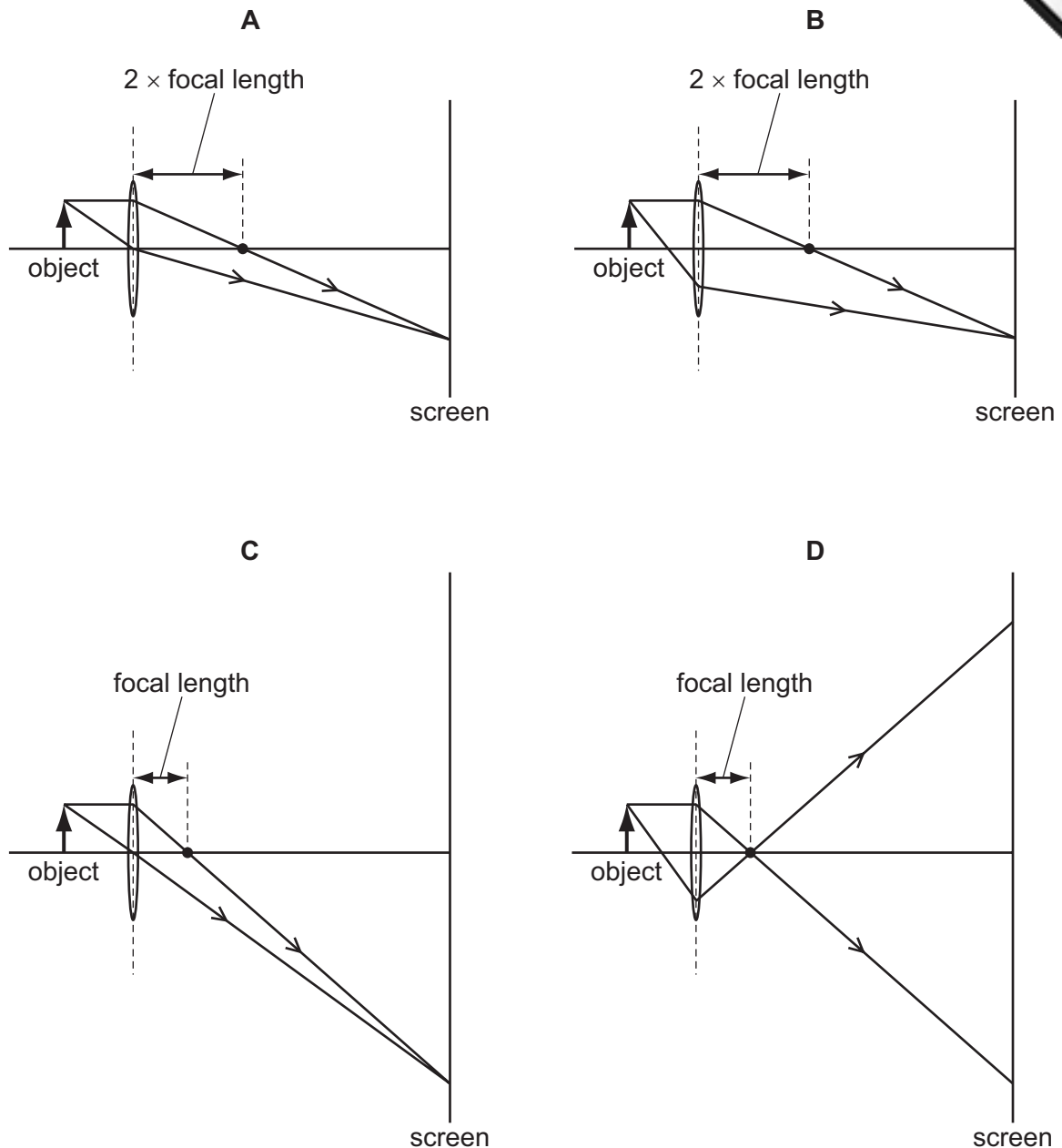

24 When the volcano Krakatoa erupted in 1883, it was heard 5000 km away.

Which statement about the sound from the volcano is **not** correct?

- A If such a loud sound were to be made today, an astronaut orbiting in space (a vacuum) at a height of 400 km could hear it.
- B People further from the volcano heard the sound later than people nearer to the volcano.
- C The amplitude of the sound waves would have been smaller further from the volcano.
- D The sound was very loud because a lot of energy was transferred to vibrations of the air.

- 25 A loudspeaker on a boat produces a pulse of sound in the sea. The echo of the pulse is heard back at the boat after 3.0 s. The depth of the sea under the boat is 2250 m.

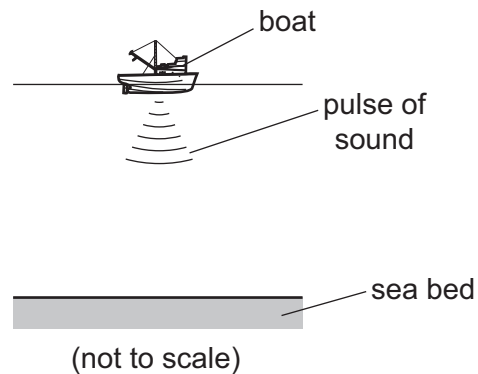

From this information, what is the speed of sound in the sea water?

- A** 330 m/s **B** 750 m/s **C** 1500 m/s **D** 6750 m/s
- 26 A hard magnetic material can be used to make a permanent magnet.
A soft magnetic material can be used to make a temporary magnet.
Which row shows whether iron and steel are hard or soft magnetic materials?

| | iron | steel |
|----------|------|-------|
| A | hard | hard |
| B | hard | soft |
| C | soft | hard |
| D | soft | soft |

- 27 How can a permanent magnet be demagnetised?
- A** cool the magnet for a long time
B hit the magnet repeatedly with a hammer
C leave the magnet in a coil which is connected to a battery
D shine bright light onto the magnet
- 28 Which equation can be used to calculate the resistance R of a resistor?
- A** $V = I \div R$ **B** $I = V \times R$ **C** $R = V \times I$ **D** $V = I \times R$

- 29 A student wishes to measure first the electromotive force (e.m.f.) of a battery, and then the potential difference (p.d.) across a resistor.

She has the resistor, the battery and some connecting wires.

What else does she need?

- A a force meter (newton meter) and a voltmeter
 B an ammeter and a voltmeter
 C an ammeter only
 D a voltmeter only
- 30 Two similar balloons hang side by side, on insulating threads, a short distance apart. They are both rubbed with the same dry cloth and become charged.

Which diagram shows how the balloons hang after charging?

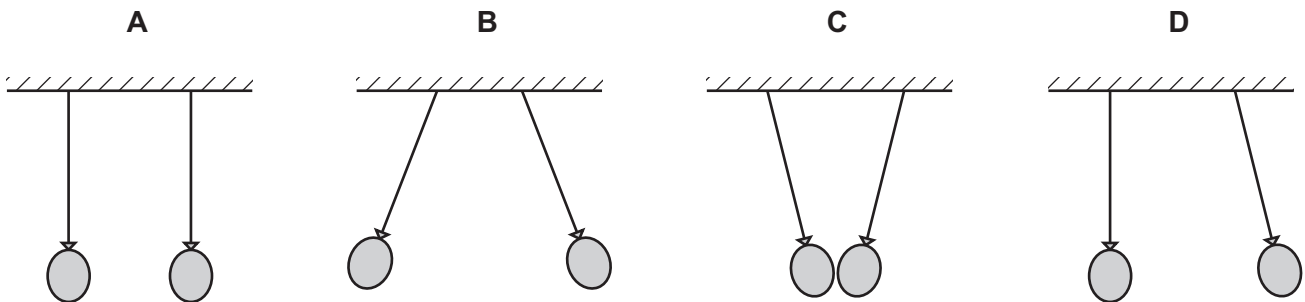

- 31 When the thermistor in the circuit below is heated, the current in the lamp increases.

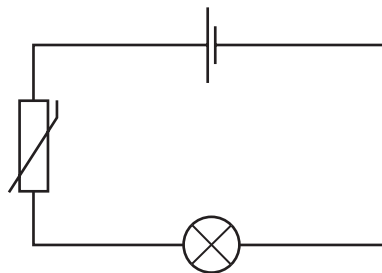

Why does this happen?

- A The resistance of the lamp decreases.
 B The resistance of the lamp increases.
 C The resistance of the thermistor decreases.
 D The resistance of the thermistor increases.

32 A student connects various resistors in parallel pairs.

Underneath each diagram is a statement about the total resistance of each pair of resistors.

Which statement is correct?

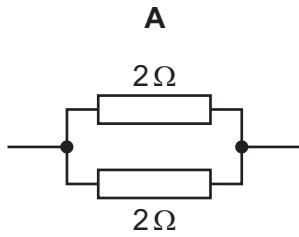

The total resistance is $4\ \Omega$.

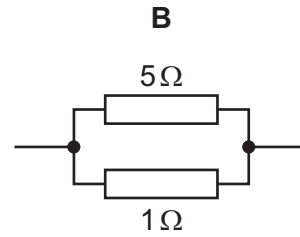

The total resistance is between $1\ \Omega$ and $5\ \Omega$.

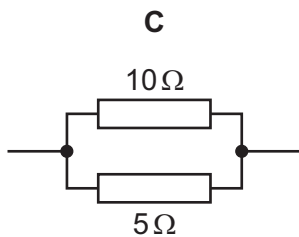

The total resistance is less than $5\ \Omega$.

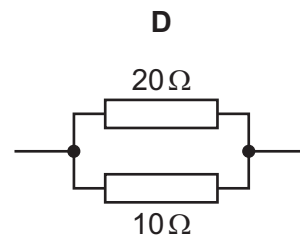

The total resistance is more than $20\ \Omega$.

33 The circuit shown contains a relay. Both lamps are initially off.

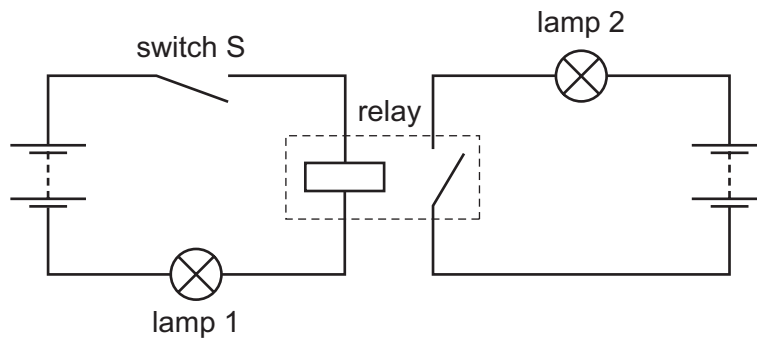

When switch S is closed, the relay operates. What is the state of the lamps?

| | lamp 1 | lamp 2 |
|----------|--------|--------|
| A | on | on |
| B | on | off |
| C | off | on |
| D | off | off |

34 The diagram shows the connections to an electric heater. Three fuses have been placed in the circuit.

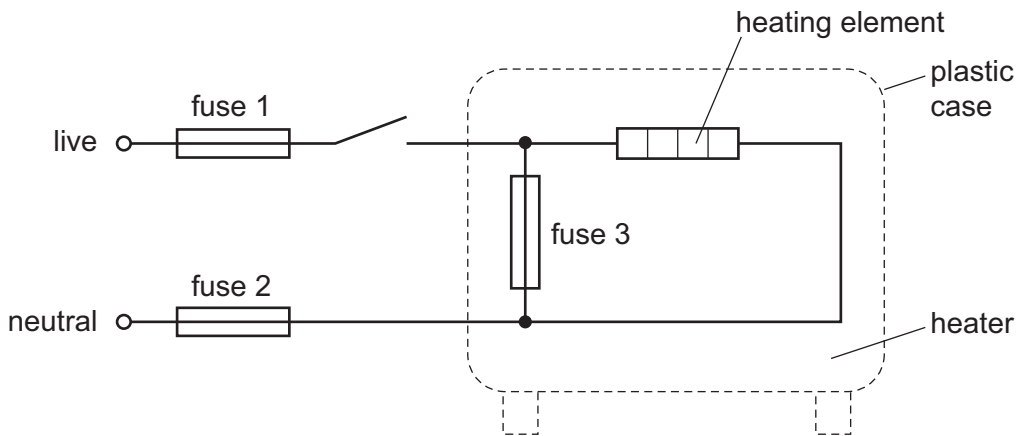

Which of the fuses are correctly placed?

- A fuse 1, fuse 2 and fuse 3
- B fuse 1 and fuse 2 only
- C fuse 1 only
- D fuse 2 only

35 Which diagram shows a movement that will **not** produce the changing magnetic field needed to induce an e.m.f. in the coil?

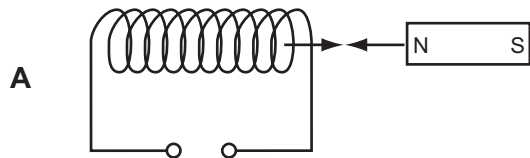

moving a magnet and a coil towards each other at the same speed

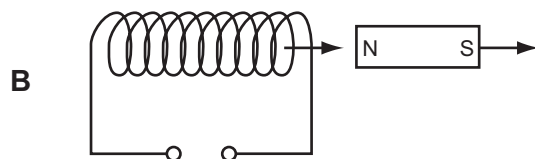

moving a magnet and a coil in the same direction at the same speed

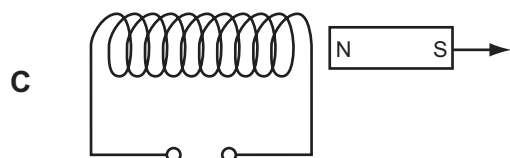

moving a magnet away from a fixed coil

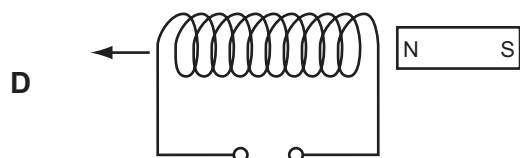

moving a coil away from a fixed magnet

36 The diagram shows a simple d.c. electric motor which is rotating.

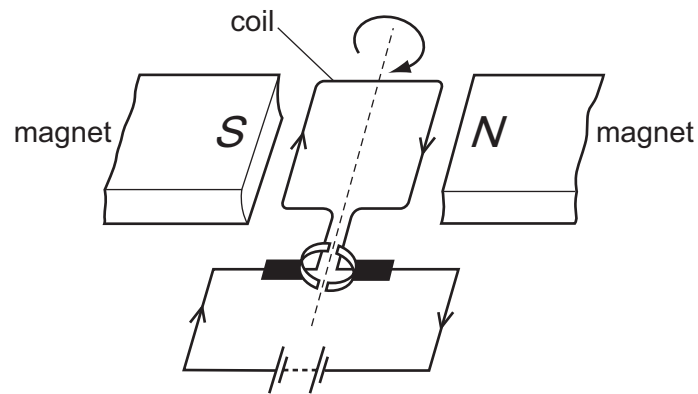

Which change will make the motor rotate more quickly?

- A increasing the number of turns on the coil
 - B removing the magnets
 - C reversing the battery
 - D reversing the polarity of the magnets
- 37 A transformer is needed to convert a supply of 240 V a.c. into 4800 V a.c.

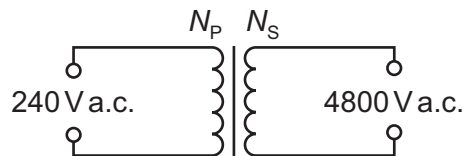

Which pair of coils would be suitable for this transformer?

| | number of turns on primary coil N_P | number of turns on secondary coil N_S |
|----------|---------------------------------------|---|
| A | 50 | 1000 |
| B | 240 | 48 000 |
| C | 480 | 24 |
| D | 2000 | 100 |

38 The diagram shows a cathode-ray tube used to produce cathode rays.

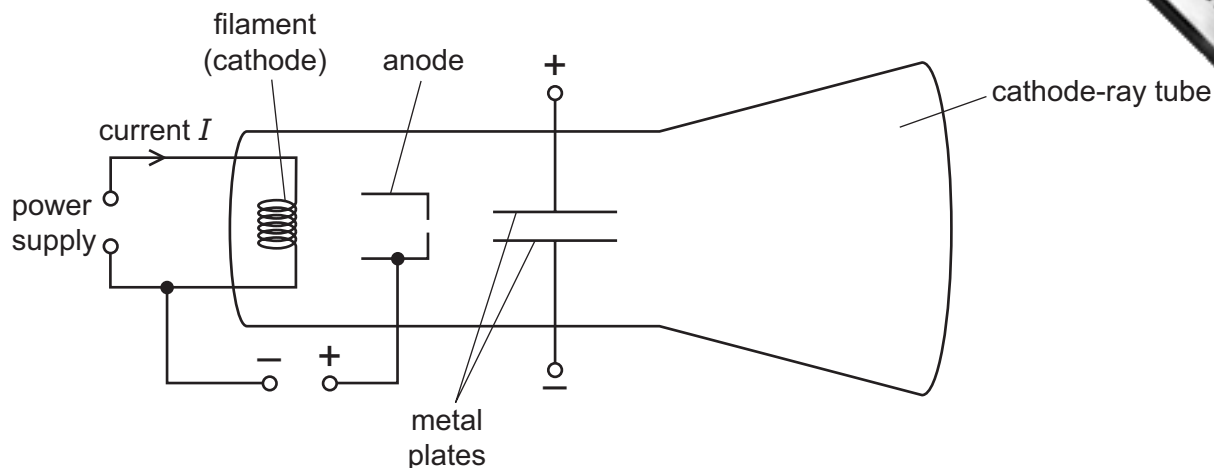

Which change would increase the deflection of the cathode rays?

- A decreasing the current I in the filament
 - B increasing the current I in the filament
 - C increasing the potential difference between the filament and the anode
 - D increasing the potential difference between the metal plates
- 39 A radioactive substance emits a particle from the nucleus of one of its atoms. The particle consists of two protons and two neutrons.

What is the name of this process?

- A α -emission
 - B β -emission
 - C γ -emission
 - D nuclear fission
- 40 A nucleus X has 17 protons and 18 neutrons.

Which notation is correct for this nucleus?

- A ${}_{18}^{17}\text{X}$
- B ${}_{35}^{17}\text{X}$
- C ${}_{17}^{18}\text{X}$
- D ${}_{17}^{35}\text{X}$

Permission to reproduce items where third-party owned material protected by copyright is included has been sought and cleared where possible. Every reasonable effort has been made by the publisher (UCLES) to trace copyright holders, but if any items requiring clearance have unwittingly been included, the publisher will be pleased to make amends at the earliest possible opportunity.

Cambridge International Examinations is part of the Cambridge Assessment Group. Cambridge Assessment is the brand name of University of Cambridge Local Examinations Syndicate (UCLES), which is itself a department of the University of Cambridge.