



Cambridge International Examinations
Cambridge International General Certificate of Secondary Education

CANDIDATE
NAME

CENTRE
NUMBER

--	--	--	--	--

CANDIDATE
NUMBER

--	--	--	--

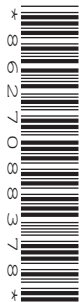

PHYSICS

0625/32

Paper 3 Extended

October/November 2014

1 hour 15 minutes

Candidates answer on the Question Paper.

No Additional Materials are required.

READ THESE INSTRUCTIONS FIRST

Write your Centre number, candidate number and name on all the work you hand in.

Write in dark blue or black pen.

You may use an HB pencil for any diagrams or graphs.

Do not use staples, paper clips, glue or correction fluid.

DO NOT WRITE IN ANY BARCODES.

Answer **all** questions.

Electronic calculators may be used.

You may lose marks if you do not show your working or if you do not use appropriate units.

Take the weight of 1 kg to be 10 N (i.e. acceleration of free fall = 10 m/s^2).

At the end of the examination, fasten all your work securely together.

The number of marks is given in brackets [] at the end of each question or part question.

The syllabus is approved for use in England, Wales and Northern Ireland as a Cambridge International Level 1/Level 2 Certificate.

This document consists of **16** printed pages.



1 (a) State the two conditions necessary for a system of forces acting on a body to be in equilibrium.

1.
2.

[2]

(b) Fig. 1.1 shows a loaded wheelbarrow held in equilibrium by a gardener. The wheel of the wheelbarrow is in contact with the ground at point C.

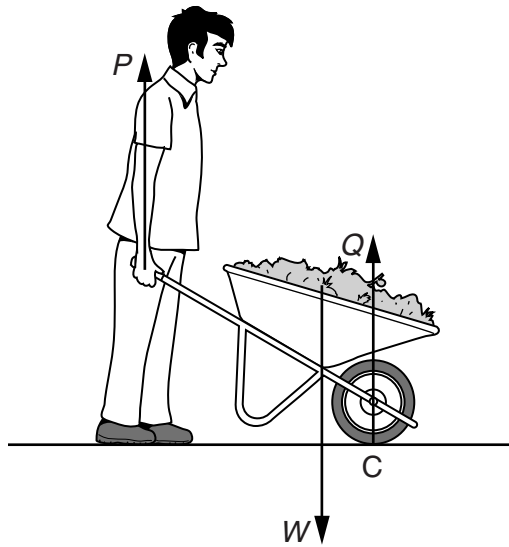

Fig. 1.1

In Fig. 1.1, there are three vertical forces acting on the wheelbarrow.

- P is the upward force applied by the gardener.
- Q is the upward force of the ground on the wheel at point C.
- W is the weight of the wheelbarrow and its contents.

Explain why the force P is less than the force W

(i) by considering the forces P , Q and W ,

-
- [2]

(ii) by considering the moments of the forces P and W about point C.

-
- [2]

3

(c) Fig. 1.2 shows a kitchen cupboard resting on a support and attached to a wall by a screw.

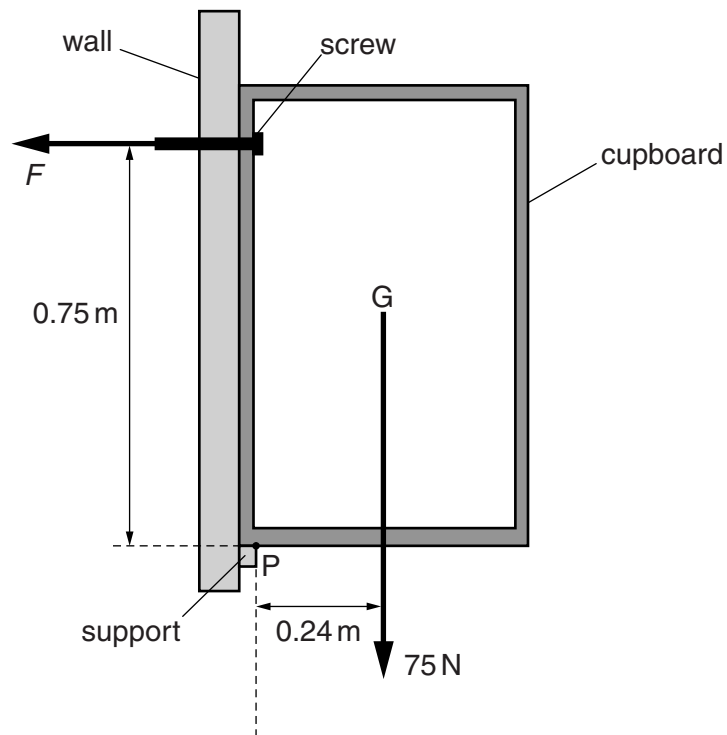

Fig. 1.2

The weight of the cupboard and its contents is 75 N . G is the position of the centre of mass of the cupboard.

The clockwise and anticlockwise moments about point P are equal.

Calculate the force F exerted by the screw.

$$F = \dots\dots\dots [3]$$

[Total: 9]

2 Fig. 2.1 shows a tanker lorry full of liquid.

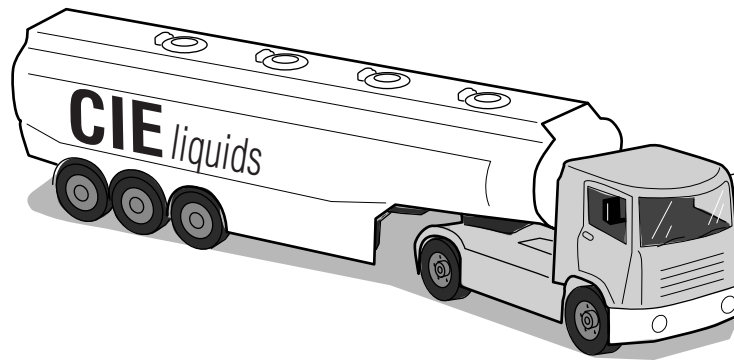

Fig. 2.1

The tanker delivers the liquid and drives away empty.

(a) (i) Compare the acceleration of the empty tanker with the acceleration of the full tanker for the same resultant force. Tick **one** box.

- acceleration of full tanker is less than acceleration of empty tanker
- acceleration of full tanker is the same as acceleration of empty tanker
- acceleration of full tanker is more than acceleration of empty tanker

[1]

(ii) Explain your answer.

.....

.....

.....

..... [2]

(b) The empty tanker has a weight of 50 000 N. The forward force is 6000 N and the total resistive force is 2000 N.

Calculate the acceleration.

acceleration = [3]

[Total: 6]

3 Fig. 3.1 shows the speed-time graph of a firework rocket as it rises and then falls to the ground.

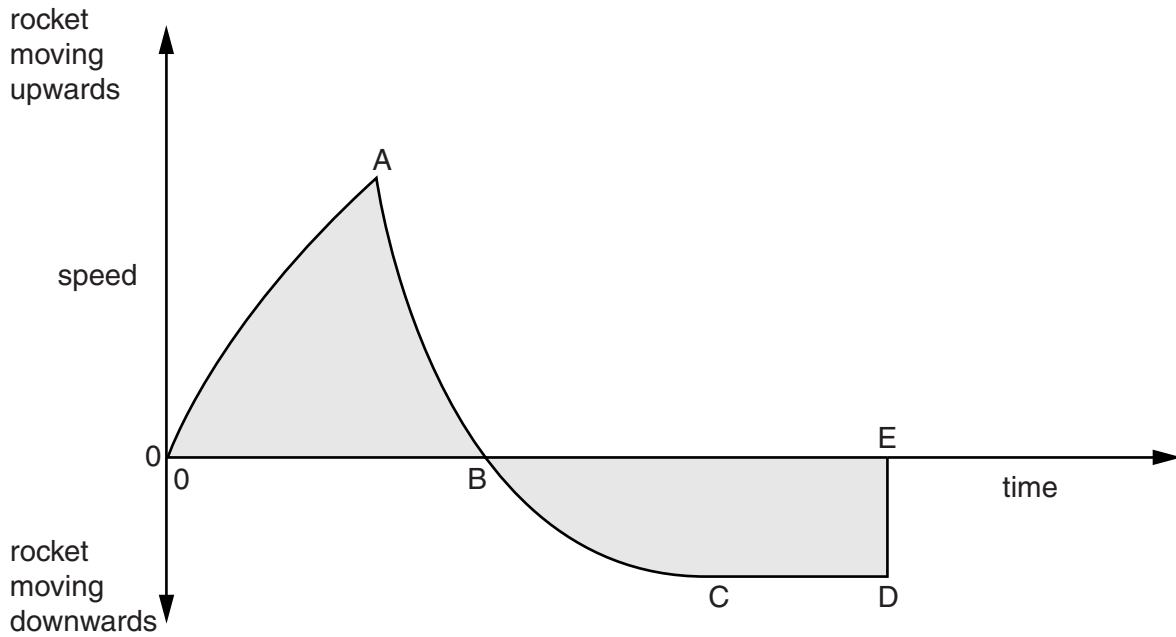

Fig. 3.1

The rocket runs out of fuel at A. It reaches its maximum height at B. At E it returns to the ground.

(a) (i) State the gradient of the graph at B. gradient = [1]

(ii) State why the gradient has this value at B.

.....
 [1]

(b) State and explain the relationship between the shaded areas above and below the time axis.

.....

 [3]

(c) Another rocket, of the same size and mass, opens a parachute at point B.

On Fig. 3.1, sketch a possible graph of its speed from B until it reaches the ground. [3]

[Total: 8]

- 4 Fig. 4.1 shows a small wind-turbine used to generate electricity.

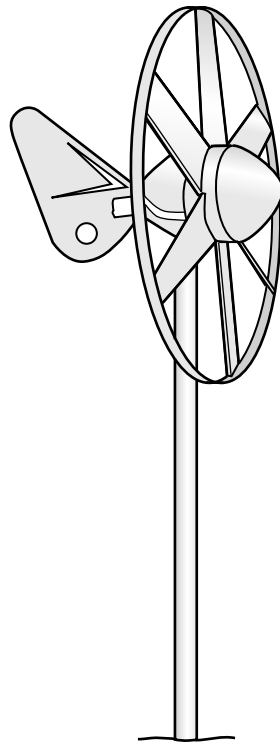

Fig. 4.1

The wind-turbine drives an electric generator.

The wind blows with a velocity of 7.0 m/s at right angles to the plane of the turbine. The mass of air passing per second through the turbine is 6.7 kg .

- (a) (i)** Calculate the kinetic energy of the air blown through the turbine per second.

kinetic energy = [2]

- (ii)** Only 8% of this energy is converted to electrical energy.

Calculate the power output of the electric generator.

power output = [2]

(b) The volume of air passing through the turbine each second is 5.6 m^3 (flow rate is $5.6\text{ m}^3/\text{s}$).

Calculate the density of the air.

density of air = [2]

(c) The turbine turns a generator.

Describe the essential action within the generator that produces electricity.

.....
.....
..... [2]

[Total: 8]

- 5 (a) In the box below, sketch a diagram to represent the molecular structure of a liquid. Show the molecules as small circles of equal size.

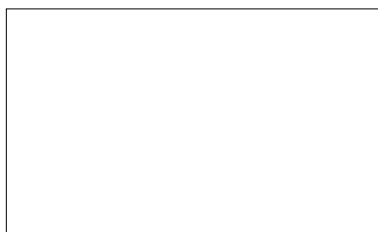

[2]

- (b) A teacher in a school laboratory pours liquid ethanol from a bottle into a glass dish. The glass dish rests on an electronic balance. Although the temperature of the laboratory is below the boiling point of ethanol, the mass of ethanol in the dish quickly decreases as ethanol evaporates.

- (i) State the effect of this evaporation on the temperature of the remaining ethanol.

..... [1]

- (ii) Explain, in terms of the ethanol molecules, why this is happening.

.....
 [1]

- (iii) The specific latent heat of vaporisation of ethanol is 850 J/g.

Calculate the thermal energy required to evaporate 3.4 g of ethanol.

thermal energy = [2]

- (iv) Suggest **two** ways in which the rate of evaporation of ethanol from the dish can be reduced.

1.
 2. [2]

[Total: 8]

- 6 A technician is designing a liquid-in-glass thermometer. The following is a list of properties of the thermometer that she is considering.

sensitivity range speed of response linearity

- (a) (i) 1. Which one of these properties is affected by the length of the stem of the thermometer?

.....

2. Explain your answer.

.....

.....

[2]

- (ii) 1. Which property is affected by the diameter of the capillary?

.....

2. Explain your answer.

.....

.....

[2]

- (b) The thermometer is to be used to measure temperatures between -10°C and 50°C . The technician considers using water or red-coloured alcohol as the liquid in the thermometer.

- (i) Write down which liquid would be suitable.

.....

- (ii) Give **two** reasons for your answer.

1.

.....

2.

.....

[2]

[Total: 6]

- 7 (a) A police car siren emits sound waves that vary in pitch.

Tick **two** boxes that apply to the sound waves emitted by the siren.

- electromagnetic
- longitudinal
- transverse
- visible
- frequency 0.1–10 Hz
- frequency 100–10 000 Hz
- frequency 100 000–1 000 000 Hz

[2]

- (b) Fig. 7.1 is a top view of one wavefront of a water wave before it strikes a hard boundary.

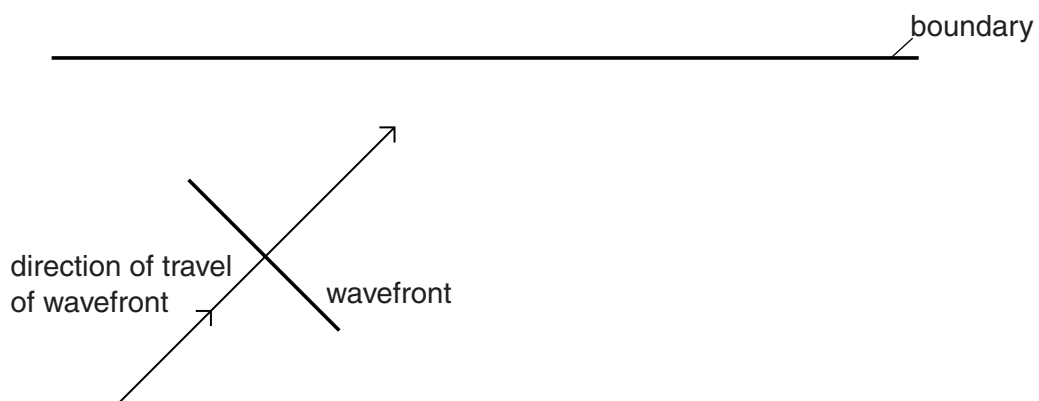

Fig. 7.1

- (i) Name the process that occurs as the wavefront strikes the boundary.

..... [1]

(ii) Explain, in terms of wave theory, what occurs as the wavefront strikes the boundary.

.....
.....
.....
.....
..... [2]

(iii) State whether there is an increase, a decrease or no change in the wavelength of the wave after it strikes the boundary.

..... [1]

(iv) The speed of the wave is 3.0 m/s and its wavelength 7.0 cm.

Calculate the frequency of the wave.

frequency = [2]

[Total: 8]

- 8 (a) Fig. 8.1 shows two resistors **X** and **Y** in series.

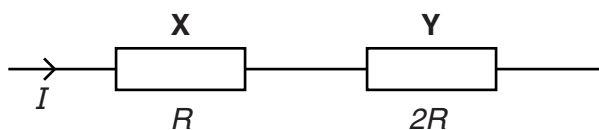

Fig. 8.1

Complete the table below, using only the symbols I and R , alone or in combination.

resistor	resistance	current	potential difference	power
X	R	I		I^2R
Y	$2R$		$2IR$	

[3]

- (b) Fig. 8.2 represents the system used to transmit electricity from a power station to a factory.

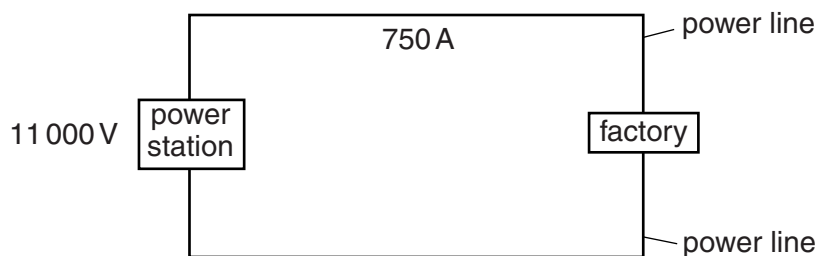

Fig. 8.2

The power station generates 11 000V and supplies a current of 750 A. The total resistance of the power lines between the power station and the factory is $1.5\ \Omega$.

Calculate

- (i) the power output of the power station,

power = [1]

(ii) the potential difference across the 1.5Ω of the power lines,

potential difference = [1]

(iii) the power supplied to the factory.

power = [3]

[Total: 8]

9 A transformer is used to reduce the voltage of a supply from 120V a.c. to 12V a.c.

(a) Explain how a transformer works. Your answer should include an explanation of why a transformer would not work with a d.c. supply voltage.

.....
.....
.....
.....
.....
.....
..... [3]

(b) The output current is 1.2 A.

(i) Calculate the input current.

input current = [2]

(ii) State an assumption you made in your calculation for (b)(i).

.....
..... [1]

[Total: 6]

10 (a) A technician sets up a radiation detector in a university laboratory for use in a class experiment.

(i) A radioactive source that emits β -particles is placed on the laboratory bench, 10 cm from the detector. A small count rate is registered.

1. State the name of the particle, found in an atom, that is identical to a β -particle.

..... [1]

2. The technician sets up the same equipment in the same way every year. He notices that the count rate registered by the detector every year is slightly smaller than it was the previous year.

Suggest why this is so.

.....

.....

..... [2]

(ii) In a second experiment, the same equipment is set up but a radioactive source that emits α -particles is placed 10 cm from the detector. The same number of particles are emitted every second from this source as were emitted from the β -source in (i).

Explain why the count rate obtained is much lower.

.....

.....

..... [2]

(b) In another experiment, β -particles pass between two parallel, horizontal metal plates in a vacuum. They then continue to the detector as shown in Fig. 10.1.

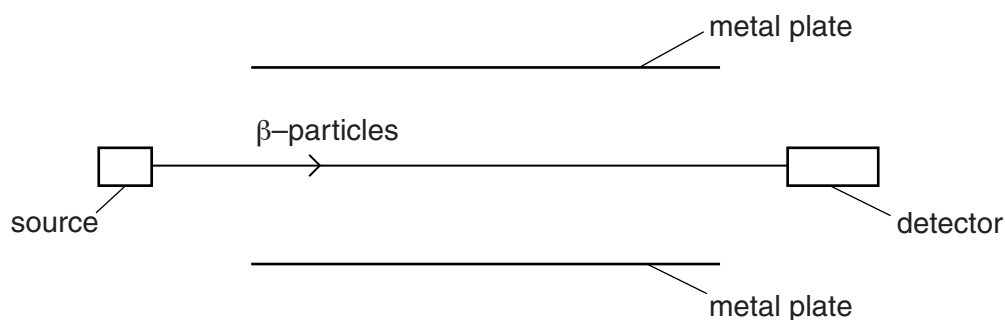

Fig. 10.1

A very high p.d. is connected between the plates, with the lower plate positive.

On Fig. 10.1, sketch the new path of the β -particles.

[2]

[Total: 7]

11 Fig. 11.1 shows part of the path of a ray of light PQ travelling in an optical fibre.

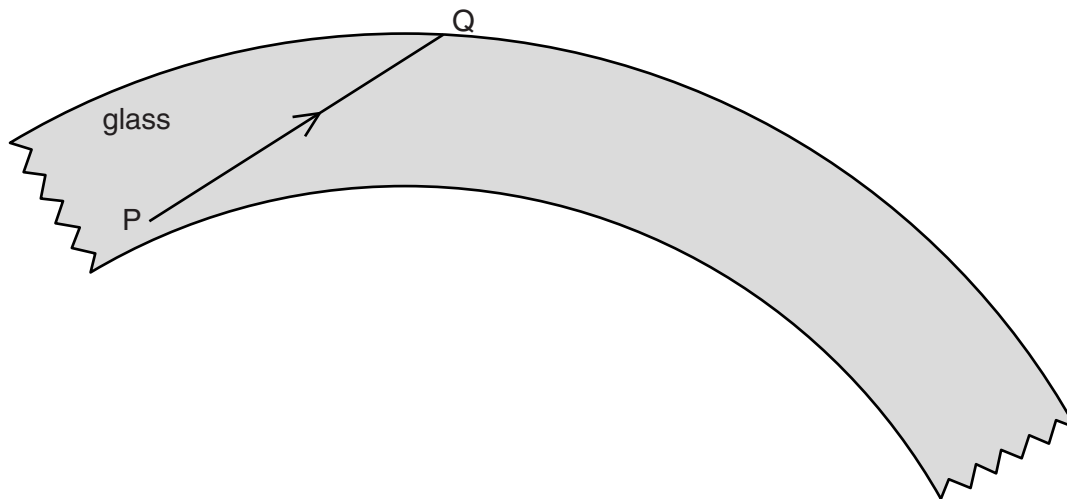

Fig. 11.1

(a) On Fig. 11.1, carefully complete the path of the ray of light, until it leaves this section of the optical fibre. [2]

(b) The material of an optical fibre has a refractive index of 1.52.

Calculate the critical angle.

critical angle =[2]

(c) (i) State what sort of reflection takes place within an optical fibre.

..... [1]

(ii) Explain your answer.

.....
 [1]

[Total: 6]

Permission to reproduce items where third-party owned material protected by copyright is included has been sought and cleared where possible. Every reasonable effort has been made by the publisher (UCLES) to trace copyright holders, but if any items requiring clearance have unwittingly been included, the publisher will be pleased to make amends at the earliest possible opportunity.

Cambridge International Examinations is part of the Cambridge Assessment Group. Cambridge Assessment is the brand name of University of Cambridge Local Examinations Syndicate (UCLES), which is itself a department of the University of Cambridge.