



**Cambridge International Examinations**  
Cambridge International General Certificate of Secondary Education

---

**PHYSICS****0625/12**

Paper 1 Multiple Choice

**May/June 2015****45 minutes**

Additional Materials:      Multiple Choice Answer Sheet  
   Soft clean eraser  
   Soft pencil (type B or HB recommended)

\* 1 0 4 1 6 2 0 3 7 7 \*



---

**READ THESE INSTRUCTIONS FIRST**

Write in soft pencil.

Do not use staples, paper clips, glue or correction fluid.

Write your name, Centre number and candidate number on the Answer Sheet in the spaces provided unless this has been done for you.

**DO NOT WRITE IN ANY BARCODES.**There are **forty** questions on this paper. Answer **all** questions. For each question there are four possible answers **A, B, C** and **D**.Choose the **one** you consider correct and record your choice in **soft pencil** on the separate Answer Sheet.**Read the instructions on the Answer Sheet very carefully.**

Each correct answer will score one mark. A mark will not be deducted for a wrong answer.

Any rough working should be done in this booklet.

Electronic calculators may be used.

---

The syllabus is approved for use in England, Wales and Northern Ireland as a Cambridge International Level 1/Level 2 Certificate.This document consists of **19** printed pages and **1** blank page.

- 1 The diagram shows four identical spheres placed between two wooden blocks on a ruler.

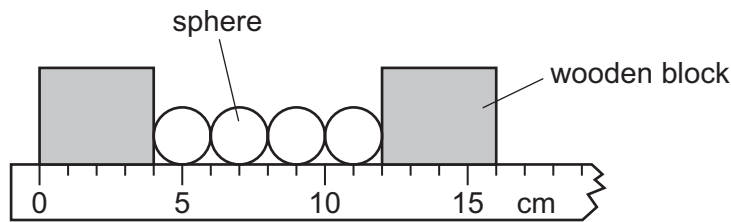

What is the diameter of one sphere?

- A** 1.0 cm      **B** 2.0 cm      **C** 3.0 cm      **D** 4.0 cm
- 2 What does the area under a speed-time graph represent?
- A** acceleration  
**B** average speed  
**C** deceleration  
**D** distance travelled
- 3 A car travels 100 km. The journey takes two hours. The highest speed of the car is 80 km/h, and the lowest speed is 40 km/h.
- What is the average speed for the journey?
- A** 40 km/h      **B** 50 km/h      **C** 60 km/h      **D** 120 km/h
- 4 The diagram shows a uniform beam being used as a balance. The beam is pivoted at its centre.
- A 1.0 N weight is attached to one end of the beam. An empty pan weighing 0.2 N is attached to the other end of the beam.

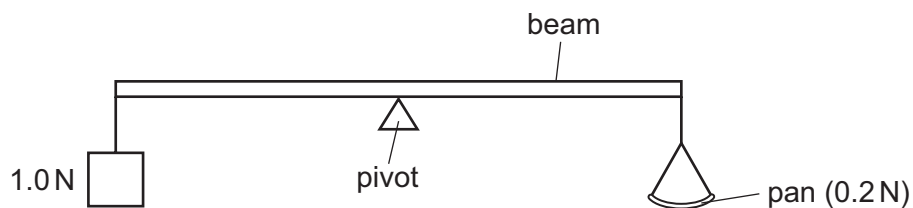

How many 0.1 N weights must be placed on the pan in order to balance the beam?

- A** 5      **B** 8      **C** 10      **D** 12

- 5 A metal block has the dimensions shown. Its mass is 1000 g.

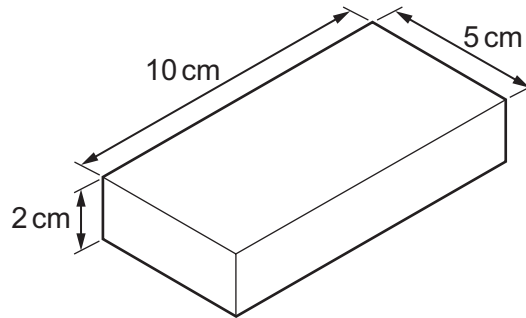

What is the density of the metal?

- A  $\left(\frac{5 \times 10}{1000 \times 2}\right) \text{g/cm}^3$
- B  $\left(\frac{2 \times 5 \times 10}{1000}\right) \text{g/cm}^3$
- C  $\left(\frac{1000 \times 2}{5 \times 10}\right) \text{g/cm}^3$
- D  $\left(\frac{1000}{2 \times 5 \times 10}\right) \text{g/cm}^3$
- 6 The diagrams show four identical objects. Each object is acted on by only the three forces shown.
- Which object accelerates to the right, with the **smallest** acceleration?

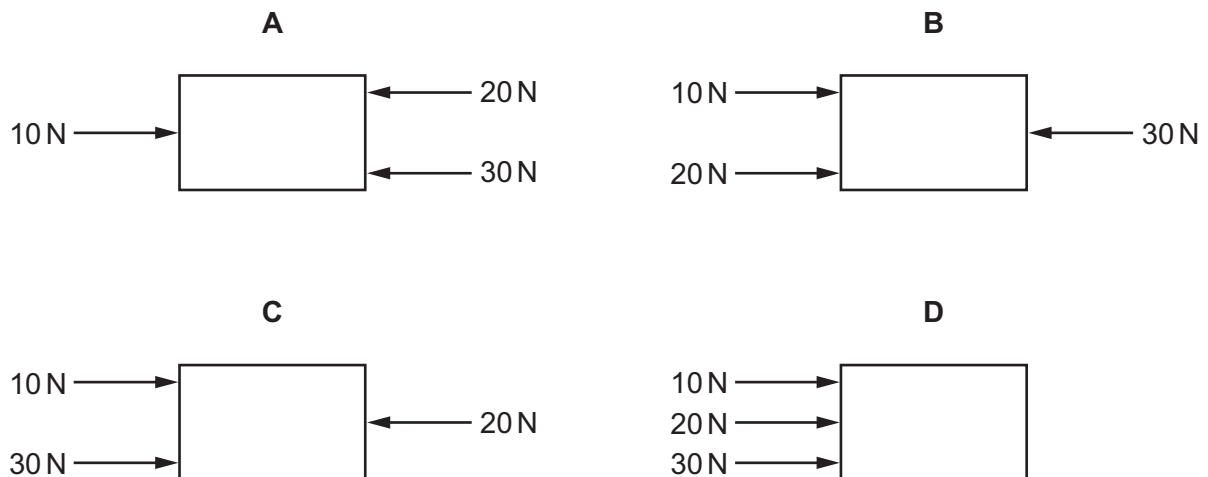

- 7 Different weights are hung from a spring. The diagram shows the original length of the spring, and the lengths when different weights are added.

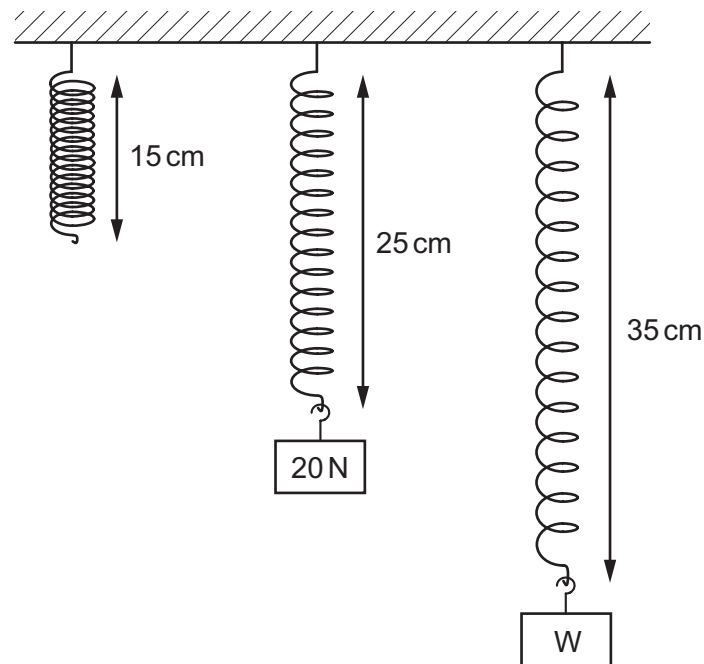

The extension of the spring is directly proportional to the weight hung from it.

What is the weight of W?

- A** 30 N                      **B** 35 N                      **C** 40 N                      **D** 45 N
- 8 Which source of energy involves the splitting of heavy atoms?
- A** chemical energy  
**B** geothermal energy  
**C** hydroelectric energy  
**D** nuclear energy

- 9 A cyclist travels down a hill from rest at point X, without pedalling.

The cyclist applies his brakes and the cycle stops at point Y.

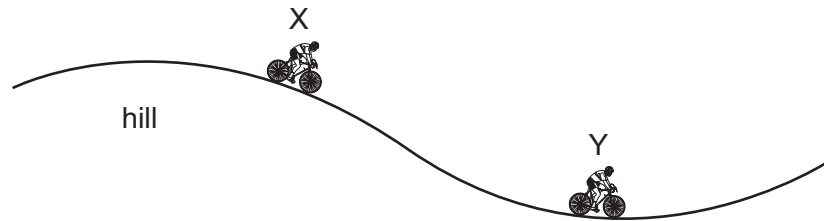

Which energy changes have taken place between X and Y?

- A gravitational potential  $\rightarrow$  kinetic  $\rightarrow$  thermal (heat)
  - B gravitational potential  $\rightarrow$  thermal (heat)  $\rightarrow$  kinetic
  - C kinetic  $\rightarrow$  gravitational potential  $\rightarrow$  thermal (heat)
  - D kinetic  $\rightarrow$  thermal (heat)  $\rightarrow$  gravitational potential
- 10 The diagram shows a stone suspended under the surface of a liquid from a string. The stone experiences a pressure caused by the liquid.

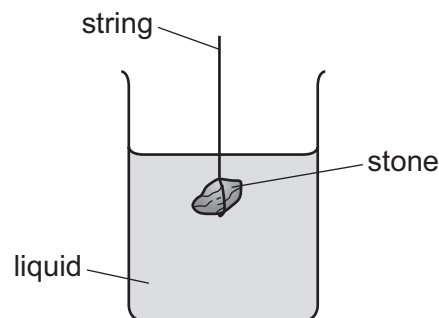

What would increase the pressure on the stone?

- A decreasing the surface area of the stone
- B increasing the mass of the stone
- C lowering the stone deeper into the liquid
- D using a liquid with a lower density

- 11 The diagram shows a simple mercury barometer, used to measure atmospheric pressure.

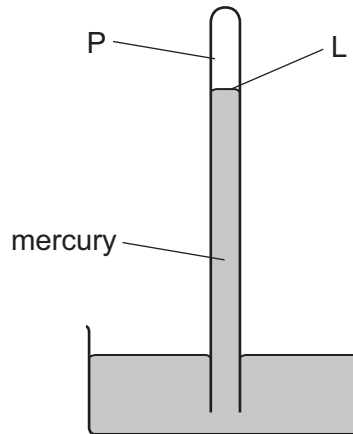

Atmospheric pressure decreases.

Which row states what happens to the pressure at point P and what happens to the level L?

|          | pressure at P  | level L |
|----------|----------------|---------|
| <b>A</b> | decreases      | falls   |
| <b>B</b> | decreases      | rises   |
| <b>C</b> | stays the same | falls   |
| <b>D</b> | stays the same | rises   |

- 12 Puddles of rain water remain after a storm. The water in the puddles gradually evaporates.

How does the evaporation affect the temperature of the water remaining in the puddle, and how does it affect the average speed of the remaining water molecules in the puddle?

|          | temperature of water in puddle | average speed of water molecules in puddle |
|----------|--------------------------------|--|
| <b>A</b> | decreases                      | decreases                                  |
| <b>B</b> | decreases                      | increases                                  |
| <b>C</b> | increases                      | decreases                                  |
| <b>D</b> | increases                      | increases                                  |

13 The diagram represents moving gas molecules in a sealed container of fixed volume.

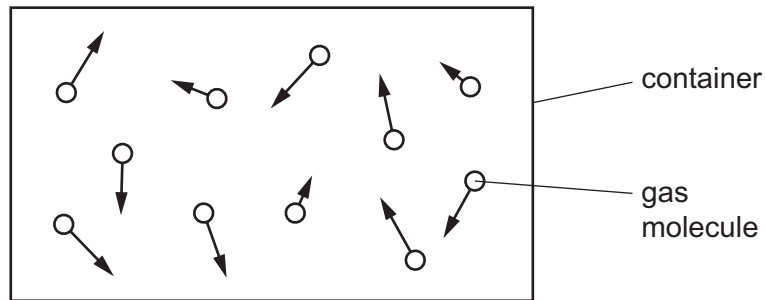

The temperature of the gas is now increased.

What happens to the pressure of the gas, and what happens to the speed of the gas molecules?

|          | pressure of gas | speed of molecules |
|----------|-----------------|--------------------|
| <b>A</b> | increases       | increases          |
| <b>B</b> | increases       | unchanged          |
| <b>C</b> | unchanged       | increases          |
| <b>D</b> | unchanged       | unchanged          |

14 The thermometer in the diagram has no scale.

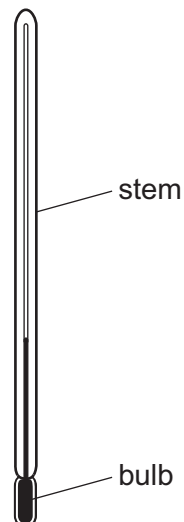

Where must the bulb be placed so that 0 °C can be marked on the stem?

- A** in a freezer
- B** in pure boiling water
- C** in pure cold water
- D** in pure melting ice

- 15 Two metal blocks X and Y are at room temperature. Each block is heated so that its temperature rises by  $10^{\circ}\text{C}$ .

The blocks are now allowed to cool back to room temperature.

Block Y has a greater thermal capacity than block X.

Which block needs more thermal (heat) energy to heat it up by  $10^{\circ}\text{C}$  and which block loses more thermal (heat) energy as it cools back to room temperature?

|          | more energy |         |
|----------|-------------|---------|
|          | heating     | cooling |
| <b>A</b> | X           | X       |
| <b>B</b> | X           | Y       |
| <b>C</b> | Y           | X       |
| <b>D</b> | Y           | Y       |

- 16 The diagram shows a vacuum flask used to keep liquid hot.

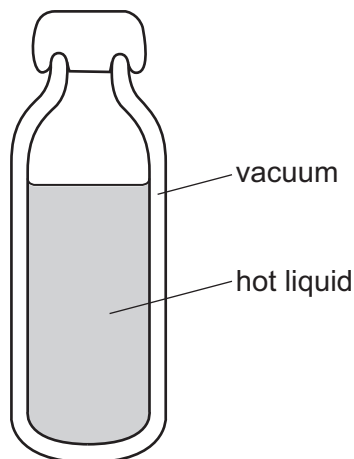

How does thermal energy pass through the vacuum?

- A** conduction only
- B** convection only
- C** radiation
- D** conduction and convection



17 A cupboard is placed in front of a heater. Air can move through a gap under the cupboard.

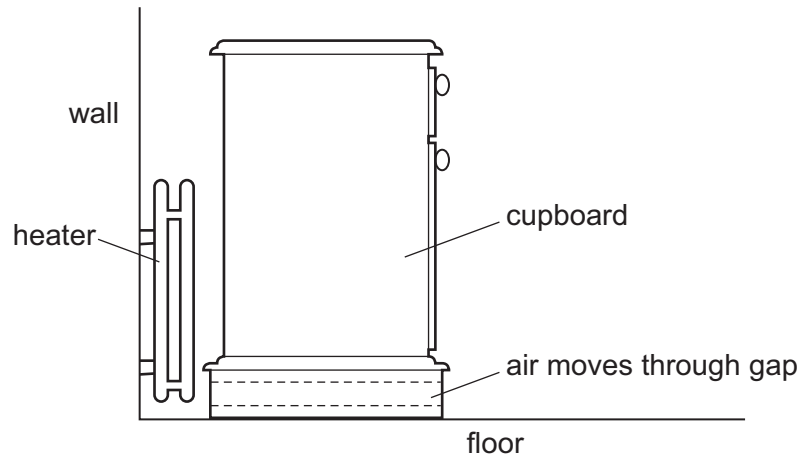

Which row describes the temperature, and the direction of movement, of the air in the gap?

|          | air temperature | air direction        |
|----------|-----------------|----------------------|
| <b>A</b> | cool            | away from the heater |
| <b>B</b> | cool            | towards the heater   |
| <b>C</b> | warm            | away from the heater |
| <b>D</b> | warm            | towards the heater   |

- 18 The diagrams show two water waves P and Q that are travelling at the same speed on the surface of a pond. The diagrams are to the same scale.

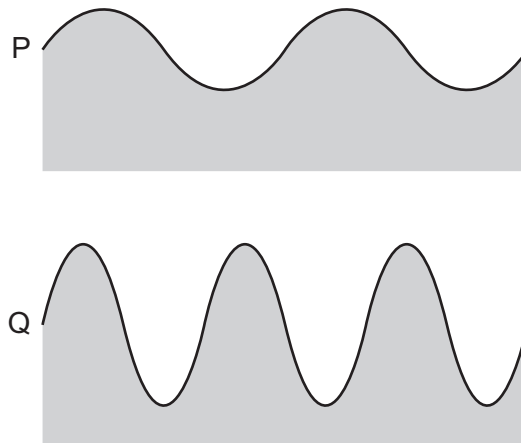

Which wave has the greater amplitude and which wave has the greater frequency?

|          | greater amplitude | greater frequency |
|----------|-------------------|-------------------|
| <b>A</b> | P                 | P                 |
| <b>B</b> | P                 | Q                 |
| <b>C</b> | Q                 | P                 |
| <b>D</b> | Q                 | Q                 |

- 19 The diagrams represent water waves in a tank.

Which diagram represents a wave that changes speed?

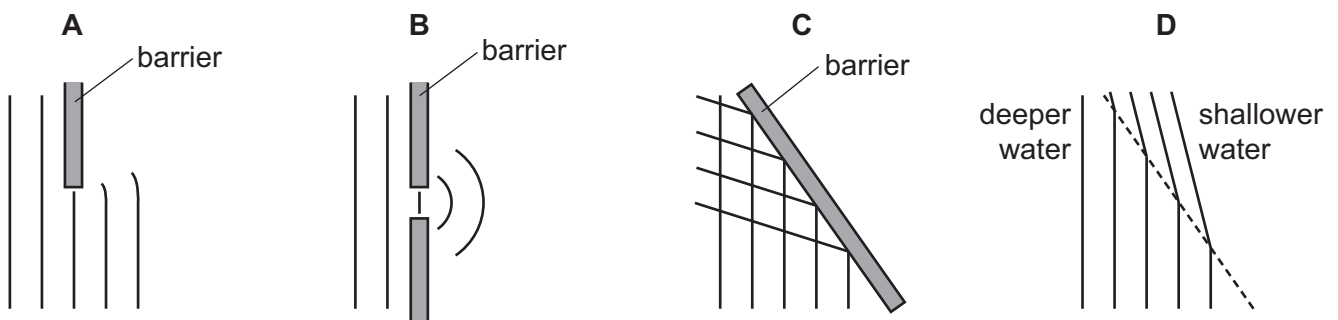

- 20 An object is placed in front of a thin converging lens.

The diagram shows the paths of two rays from the top of the object.

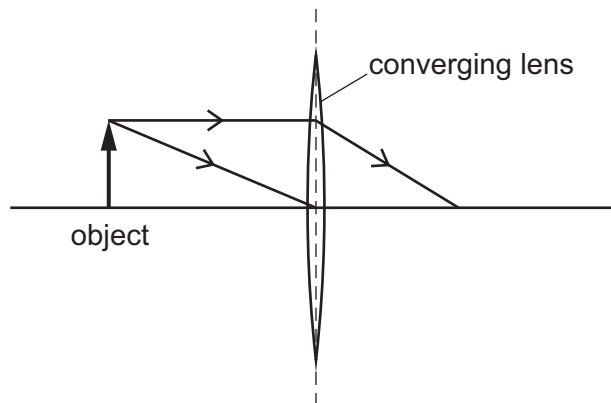

An image of the object is formed on a screen to the right of the lens.

How does this image compare with the object?

- A It is larger and inverted.
  - B It is larger and the same way up.
  - C It is smaller and inverted.
  - D It is smaller and the same way up.
- 21 Radiation from the Sun is dispersed by a prism. The prism does not absorb any of the radiation. Four identical thermometers are placed, one at each of the labelled positions.

In which position does the thermometer show the greatest rise in temperature?

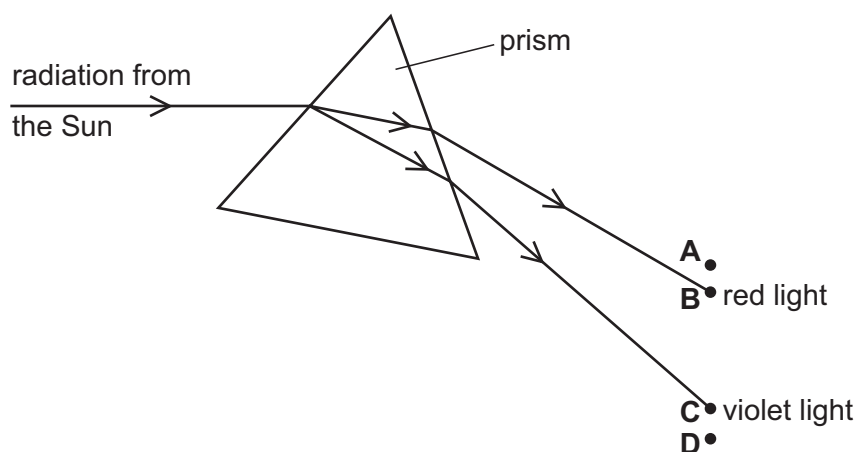

- 22 A scientist tries to direct a ray of light in a glass block so that no light escapes from the top of the block.

However, some light does escape.

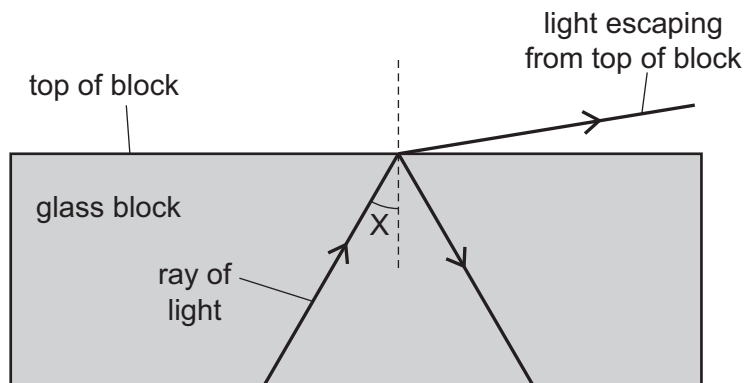

The scientist changes angle  $X$  and stops the light escaping from the top.

Which row in the table describes the change to angle  $X$  and the name of the effect produced?

|          | change to angle $X$ | name of effect produced   |
|----------|---------------------|---------------------------|
| <b>A</b> | decrease            | total internal reflection |
| <b>B</b> | decrease            | total internal refraction |
| <b>C</b> | increase            | total internal reflection |
| <b>D</b> | increase            | total internal refraction |

- 23 A quiet sound is produced by a loudspeaker. The loudness of the sound is increased.

Which property of the sound wave is increased?

- A** amplitude
- B** frequency
- C** speed
- D** wavelength

- 24 A man holding a starting pistol stands 640 m away from a spectator.

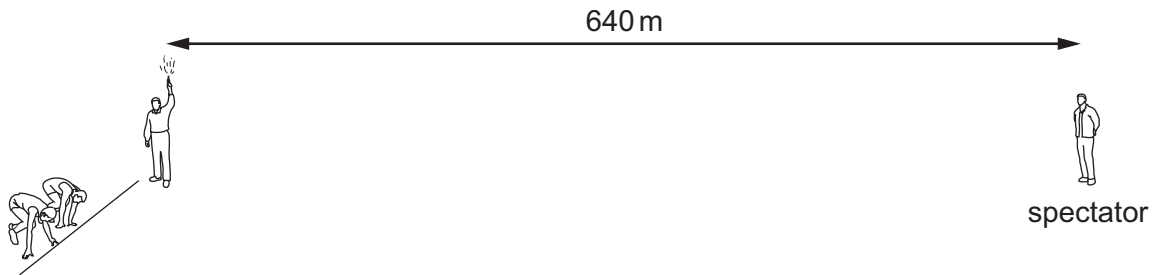

The spectator hears the sound of the starting pistol 2.0 s after seeing the flash from the pistol.

Using this information, what is the speed of sound in air?

- A 160 m/s      B 320 m/s      C 640 m/s      D 1280 m/s
- 25 Which group contains only non-ferrous metals?
- A aluminium, brass, iron  
 B brass, copper, lead  
 C copper, iron, steel  
 D copper, lead, steel
- 26 An electromagnet with a soft-iron core is connected to a battery and an open switch. The soft-iron core is just above some small soft-iron nails.

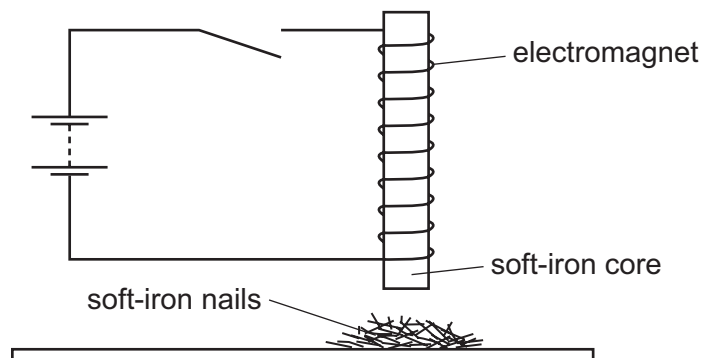

The switch is now closed, left closed for a few seconds, and then opened.

What do the soft-iron nails do as the switch is closed, and what do they do when the switch is then opened?

|          | as switch is closed | as switch is opened |
|----------|---------------------|---------------------|
| <b>A</b> | nails jump up       | nails fall down     |
| <b>B</b> | nails jump up       | nails stay up       |
| <b>C</b> | nails stay down     | nails jump up       |
| <b>D</b> | nails stay down     | nails stay down     |

- 27 A student has wires of different lengths and different diameters. The wires are all made of the same metal.

The student measures the resistance of one wire.

Which wire has a greater resistance than the wire he has measured?

- A a shorter wire with a larger diameter
  - B a shorter wire with the same diameter
  - C a wire of the same length with a larger diameter
  - D a wire of the same length with a smaller diameter
- 28 The circuit diagram shows a  $4.0\ \Omega$  resistor and an  $8.0\ \Omega$  resistor connected to a  $6.0\ \text{V}$  battery.

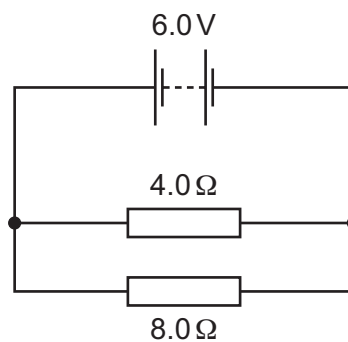

What is the potential difference (p.d.) across the  $4.0\ \Omega$  resistor?

- A 0.5 V
- B 2.0 V
- C 4.0 V
- D 6.0 V

29 Diagram 1 shows two thin, uncharged strips of plastic.

Diagram 2 shows the same strips after they have been rubbed with a dry cloth.

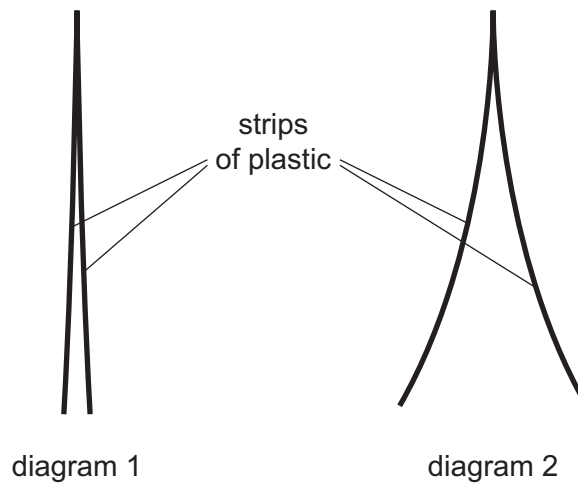

Which row describes the charge on the strips after rubbing, and the force between the strips after rubbing?

|          | charge on strips | force between strips |
|----------|------------------|----------------------|
| <b>A</b> | opposite         | attraction           |
| <b>B</b> | opposite         | repulsion            |
| <b>C</b> | the same         | attraction           |
| <b>D</b> | the same         | repulsion            |

- 30 The diagram shows a circuit which includes an uncharged capacitor and a switch.

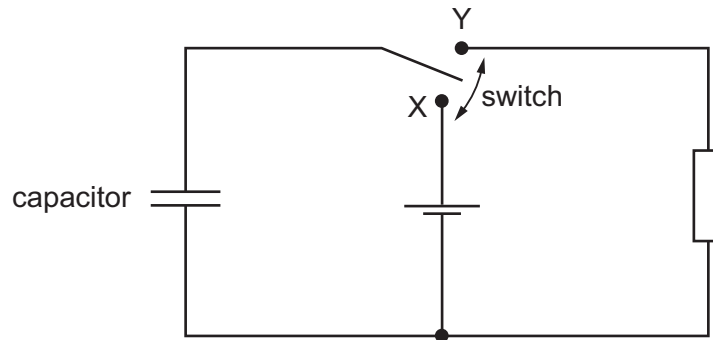

The switch can be moved between position X and position Y.

What happens to the capacitor when the switch is moved to position X, and what happens when the switch is then moved to position Y?

|          | switch at X          | switch at Y          |
|----------|----------------------|----------------------|
| <b>A</b> | capacitor charges    | capacitor charges    |
| <b>B</b> | capacitor charges    | capacitor discharges |
| <b>C</b> | capacitor discharges | capacitor charges    |
| <b>D</b> | capacitor discharges | capacitor discharges |

- 31 Two  $5.0\ \Omega$  resistors are connected as shown in the diagram.

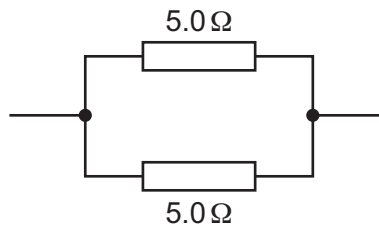

What is the total resistance of this combination?

- A** less than  $5.0\ \Omega$
- B**  $5.0\ \Omega$
- C** more than  $5.0\ \Omega$  but less than  $10.0\ \Omega$
- D**  $10.0\ \Omega$



- 32 The diagram shows a  $10\ \Omega$  resistor and a  $20\ \Omega$  resistor connected in a potential divider circuit.

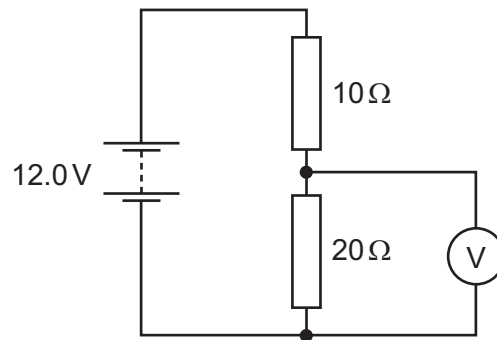

What is the reading on the voltmeter?

- A** 4.0V      **B** 6.0V      **C** 8.0V      **D** 12.0V
- 33 In the circuit shown, only one of the fuses has blown, but none of the lamps is lit.

Which fuse has blown?

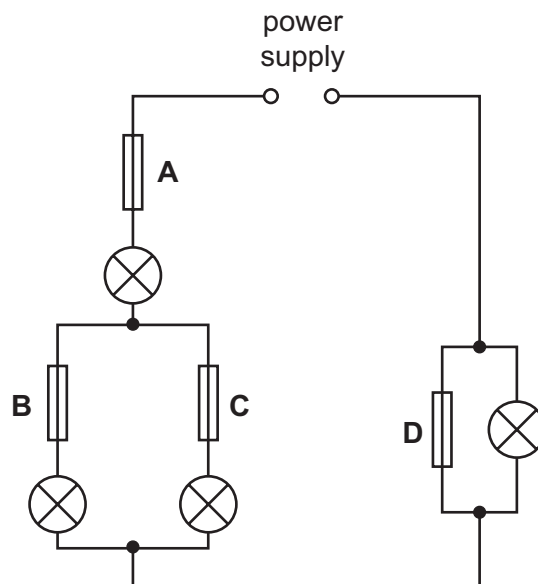

- 34 An e.m.f. is induced across a wire when it moves through the magnetic field between the poles of a magnet.

Which electrical device operates because of this effect?

- A a battery
- B a cathode-ray tube
- C a generator
- D a motor

- 35 The diagram shows a flat, rectangular coil placed between the poles of a magnet.

There is a current in the coil that makes it turn in the direction shown in the diagram.

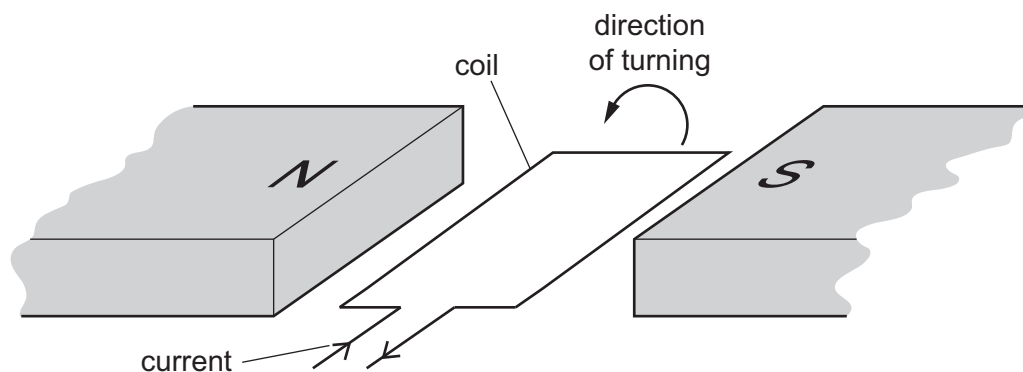

Which change would make the coil turn in the opposite direction?

- A decreasing the current in the coil
  - B increasing the number of turns on the coil
  - C reversing both the direction of the current in the coil and the poles of the magnet
  - D reversing only the direction of the current in the coil
- 36 A transformer has 1000 turns on its primary coil. An input voltage of 12V is applied to the primary coil, and an output voltage of 120V is induced across the secondary coil.

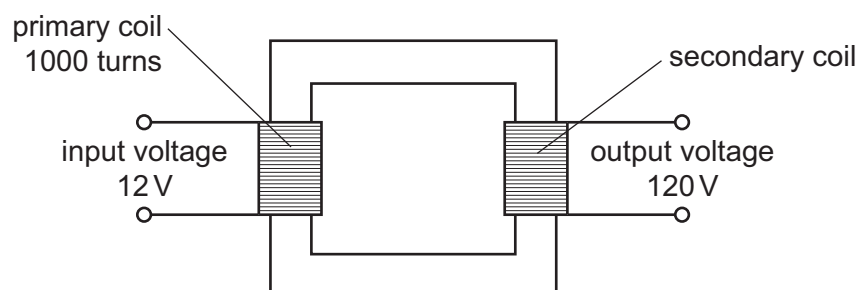

How many turns are on the secondary coil of the transformer?

- A 100
- B 120
- C 1000
- D 10000

37 The diagram shows a cathode-ray tube.

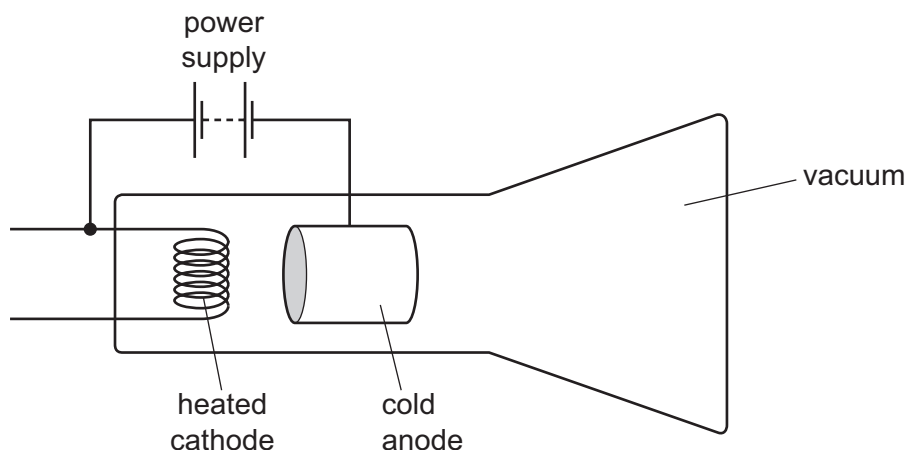

The tube is not working properly.

Which change should be made so that the tube works properly to produce a continuous beam of cathode rays?

- A** Heat the anode instead of the cathode.
- B** Reverse the connections of the power supply.
- C** Use an a.c. power supply instead of a d.c. power supply.
- D** Use air in the tube instead of a vacuum.
- 38 Which statement about  $\alpha$ -radiation is correct?
- A** It is a stream of fast-moving electrons.
- B** It is a form of electromagnetic radiation.
- C** It is more highly ionising than  $\gamma$ -radiation.
- D** It is more penetrating than  $\beta$ -radiation.
- 39 A radioactive source produces a count rate on a detector of 1600 counts/s.
- After 32 hours the count rate has fallen to 100 counts/s.
- Both count rates have been corrected for background radiation.
- What is the half-life of the source?
- A** 2.0 hours      **B** 6.4 hours      **C** 8.0 hours      **D** 16 hours
- 40 A nuclide has the symbol  ${}_{10}^{22}\text{Ne}$ .
- What is the proton number of a nucleus of this nuclide?
- A** 10      **B** 12      **C** 22      **D** 32

**BLANK PAGE**

---

Permission to reproduce items where third-party owned material protected by copyright is included has been sought and cleared where possible. Every reasonable effort has been made by the publisher (UCLES) to trace copyright holders, but if any items requiring clearance have unwittingly been included, the publisher will be pleased to make amends at the earliest possible opportunity.

To avoid the issue of disclosure of answer-related information to candidates, all copyright acknowledgements are reproduced online in the Cambridge International Examinations Copyright Acknowledgements Booklet. This is produced for each series of examinations and is freely available to download at [www.cie.org.uk](http://www.cie.org.uk) after the live examination series.

Cambridge International Examinations is part of the Cambridge Assessment Group. Cambridge Assessment is the brand name of University of Cambridge Local Examinations Syndicate (UCLES), which is itself a department of the University of Cambridge.