



**Cambridge International Examinations**  
Cambridge International General Certificate of Secondary Education

---

**PHYSICS**

**0625/52**

Paper 5 Practical Test

**February/March 2016**

CONFIDENTIAL INSTRUCTIONS

**Great care should be taken to ensure that any confidential information given does not reach the candidates either directly or indirectly.**

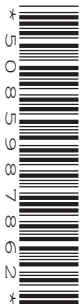

---

If you have any problems or queries regarding these Instructions, please contact CIE  
by e-mail: [info@cie.org.uk](mailto:info@cie.org.uk),  
by phone: +44 1223 553554,  
by fax: +44 1223 553558,  
stating the Centre number, the nature of the query and the syllabus number quoted above.

---

The syllabus is approved for use in England, Wales and Northern Ireland as a Cambridge International Level 1/Level 2 Certificate.

This document consists of **8** printed pages.

### Instructions for preparing apparatus

The Supervisor is **not** allowed to consult the Question Paper before the examination. This teacher should, as part of the preparation of the examination requirements, test the apparatus in order to ensure that it is satisfactory.

The Supervisor is asked to give (and attach to the Report form printed on pages 7 and 8) a *brief* description of the apparatus supplied, mentioning any points that are likely to be of importance to the Examiner in marking the answers. The Supervisor should also report any assistance given to candidates. All reports should be signed by the Supervisor and by the person responsible for preparing the apparatus.

In addition to the usual equipment of a physics laboratory, each candidate will require the apparatus specified in these Instructions. If a candidate breaks any of the apparatus, or loses any of the material supplied, the matter should be rectified and a note made in the Report.

### Number of sets of apparatus

As a *minimum*, the number of sets of apparatus provided should be  $N/3$ , where  $N$  is the number of candidates (per session). A few spare sets should, preferably, be available to avoid any candidate being delayed when moving to another question.

The order in which a given candidate attempts the four questions is immaterial. It is suggested that candidates spend **about 20 minutes on each of questions 1 to 3, followed by 15 minutes on question 4.**

### Assistance to Candidates

The purpose of the Practical Physics test is to find out whether the candidates can carry out simple practical work themselves. The Examiners are aware that candidates may sometimes be unable to show their practical ability through failure to understand some point in the theory of the experiment. If an Examiner were present in the laboratory, he/she would be willing to give a hint to enable such a candidate to get on with an experiment. In order to overcome this difficulty, the Supervisor is asked to co-operate with the Examiners to the extent of being ready to give (or allow the Physics teacher to give) a hint to a candidate who is unable to proceed.

The following regulations must be strictly adhered to.

- (i) No hint may be announced to the candidates as a whole.
- (ii) A candidate who is unable to proceed and requires assistance must come up to the Supervisor and state the difficulty. Candidates should be told that the Examiners will be informed of any assistance given in this way.
- (iii) A report must be made of any assistance given to the candidate, with the name and candidate number of the candidate.

It is suggested that the following announcement be made to the candidates.

'The Examiners do not want you to waste time through inability to get on with an experiment. Any candidate, therefore, who is unable to get on with the experiment after spending five minutes at it may come to me and ask for help. I shall report to the Examiners any help given in this way, and some marks may be lost for the help given. You may ask me for additional apparatus which you think would improve the accuracy of your experiments, and you should say, on your script, how you use any such apparatus supplied.'

**Question 1****Items to be supplied by the Centre (per set of apparatus unless otherwise specified)**

- (i) Boiling tube (approximate capacity between 50 and 70 cm<sup>3</sup>).
- (ii) 2 rectangular wooden blocks. See note 1.
- (iii) 100 cm<sup>3</sup> or 250 cm<sup>3</sup> measuring cylinder.
- (iv) Top pan balance with a resolution of at least 1 g. This item may be shared but enough should be available so that candidates have easy, individual access.
- (v) 50 cm or 30 cm ruler, graduated in mm. Candidates may use their own.
- (vi) Supply of water. Each candidate will require about 100 cm<sup>3</sup>. The temperature of the water is not important.
- (vii) Supply of paper towels to mop up any spillages of water.

**Notes**

1. Each block should be approximately 10 cm long. The width and thickness must be greater than the diameter of the boiling tube.
2. Spare boiling tubes should be available.

**Action at changeover**

Check that the apparatus is ready for the next candidate.

**Question 2****Items to be supplied by the Centre (per set of apparatus unless otherwise specified)**

- (i) A bare resistance wire about 105 cm in length. 32 swg (0.274 mm diameter) constantan (Eureka), or any other wire with a resistance of approximately  $8 \Omega \text{ m}^{-1}$ , is suitable. See note 1.
- (ii) Resistor, approximately  $5 \Omega$ , 2W. The value must be hidden, e.g. taped over.
- (iii) Metre rule or wooden strip. See note 1.
- (iv) Power supply of approximately 3V. See note 3. Where candidates are provided with a variable power supply, the voltage should be set by the Supervisor and fixed, e.g. taped.
- (v) Switch. The switch may be an integral part of the power supply.
- (vi) Sufficient connecting leads to set up the circuit shown in Fig. 2.1.
- (vii) Crocodile clip.
- (viii) Ammeter capable of measuring currents up to 1.00 A with a minimum resolution of 0.05 A. See note 4.
- (ix) Voltmeter capable of measuring up to 3.0 V with a minimum resolution of 0.1 V. See note 4.

**Notes**

1. The resistance wire is to be fixed to the metre rule or wooden strip in such a way as to allow candidates to connect a crocodile clip to points between 10 cm and 90 cm from the left-hand end of the wire.
2. The circuit is to be set up for candidates as shown in Fig. 2.1, with the crocodile clip connected to the resistance wire. The position of the crocodile clip is not important.

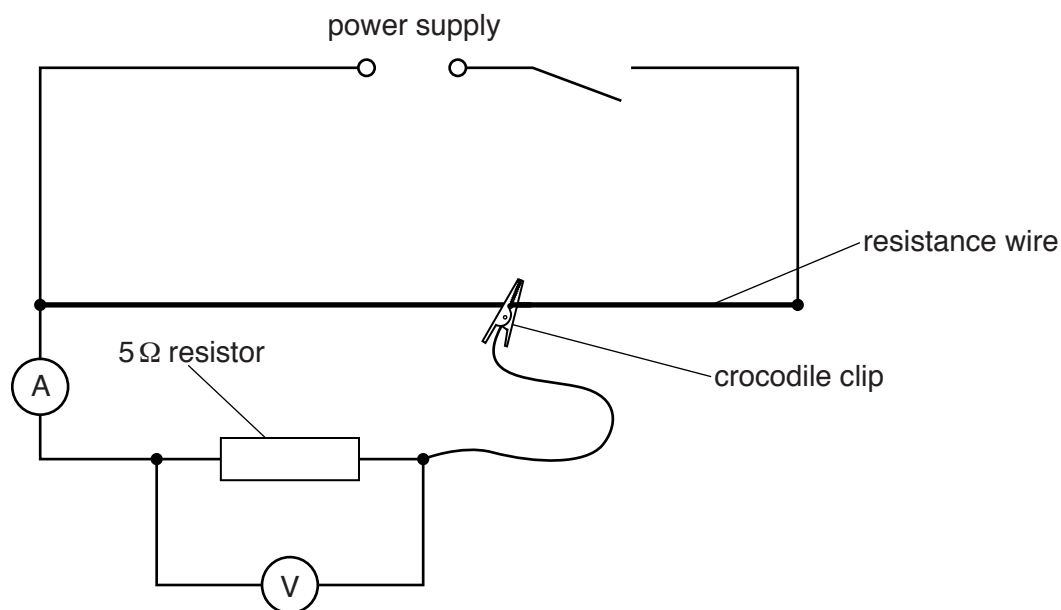
**Fig. 2.1**

3. When the crocodile clip is connected to the maximum length of the resistance wire, the reading on the voltmeter should be at least 2.2V. If cells are used, they must remain adequately charged throughout the examination. Spare cells must be available.
4. Either analogue or digital meters are suitable. Any variable settings should be set by the Supervisor and fixed, e.g. taped.
5. Spare resistors, leads, crocodile clips and meters should be available.

**Action at changeover**

Ensure that the circuit is connected as shown in Fig. 2.1 and check that the circuit is working. Switch the circuit off.

**Question 3****Items to be supplied by the Centre (per set of apparatus unless otherwise specified)**

- (i) Sheet of plain A4 paper (per candidate) with a hole in one corner so that it can be tied into the Question Paper.
- (ii) Rectangular, transparent glass or Perspex block, 10 cm x 6 cm x 1.5 cm or similar size.
- (iii) 4 optics pins.
- (iv) Pin board (e.g. cork mat), A4 size or larger.
- (v) 50 cm or 30 cm ruler, graduated in mm. Candidates may use their own.
- (vi) Protractor. Candidates may use their own.
- (vii) String or treasury tag (per candidate) to tie the ray-trace sheet, (i) above, into the Question Paper.

**Notes**

1. Spare sheets of plain paper, as in (i) above, and pins should be available.

**Action at changeover**

Supply a sheet of plain A4 paper, as in (i) above, and string or treasury tag, as in (vii) above.

**Question 4**

No apparatus is required for this question.

---

Permission to reproduce items where third-party owned material protected by copyright is included has been sought and cleared where possible. Every reasonable effort has been made by the publisher (UCLES) to trace copyright holders, but if any items requiring clearance have unwittingly been included, the publisher will be pleased to make amends at the earliest possible opportunity.

To avoid the issue of disclosure of answer-related information to candidates, all copyright acknowledgements are reproduced online in the Cambridge International Examinations Copyright Acknowledgements Booklet. This is produced for each series of examinations and is freely available to download at [www.cie.org.uk](http://www.cie.org.uk) after the live examination series.

Cambridge International Examinations is part of the Cambridge Assessment Group. Cambridge Assessment is the brand name of University of Cambridge Local Examinations Syndicate (UCLES), which is itself a department of the University of Cambridge.

**This form must be completed and returned with the scripts.**

### **REPORT ON PRACTICAL PHYSICS**

#### *General*

The Supervisor is required to give details of any difficulties experienced by particular candidates giving their names and candidate numbers. These should include reference to:

- (a) difficulties due to faulty apparatus;
- (b) accidents to apparatus or materials;
- (c) any other information that is likely to assist the Examiner, especially if this cannot be discovered in the scripts;
- (d) any help given to a candidate.

#### *Information required*

A plan of workbenches, giving details by candidate number of the places occupied by the candidates for each experiment for each session, must be enclosed with the scripts. The space below can be used for this, or it may be on separate paper.



*Information required (cont.)*

A list by name and candidate number of candidates requiring help, with details of the help provided.

CENTRE NO. ....

NAME OF CENTRE .....

*Declaration (to be signed by the Supervisor and the person responsible for preparing the apparatus)*

The preparation of the practical examination has been carried out so as to maintain fully the security of the examination.

SIGNED .....  
Supervisor

SIGNED .....  
Person responsible for preparing the apparatus

