



UNIVERSITY OF CAMBRIDGE INTERNATIONAL EXAMINATIONS  
International General Certificate of Secondary Education

CANDIDATE  
NAME

CENTRE  
NUMBER

--	--	--	--	--

CANDIDATE  
NUMBER

--	--	--	--

\* 9 5 0 5 1 6 4 1 8 9 \*

**COMBINED SCIENCE**

**0653/03**

Paper 3 (Extended)

**May/June 2007**

**1 hour 15 minutes**

Candidates answer on the Question Paper.

No Additional Materials are required.

**READ THESE INSTRUCTIONS FIRST**

Write your Centre number, candidate number and name on all the work you hand in.

Write in dark blue or black pen.

You may use a soft pencil for any diagrams, graphs, tables or rough working.

Do not use staples, paper clips, highlighters, glue or correction fluid.

**DO NOT WRITE IN ANY BARCODES.**

Answer **all** questions.

A copy of the Periodic Table is printed on page 16.

At the end of the examination, fasten all your work securely together.

The number of marks is given in brackets [ ] at the end of each question or part question.

For Examiner's Use	
1	
2	
3	
4	
5	
6	
7	
8	
9	
<b>Total</b>	

This document consists of **16** printed pages.



1 Fig. 1.1 shows a vertical section through a human heart.

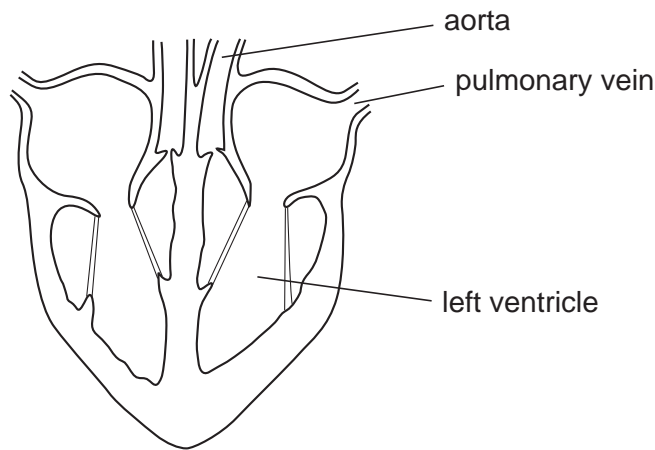

Fig. 1.1

(a) On the diagram, use label lines to label these parts of the heart. [3]

**bicuspid valve**

**pulmonary artery**

**septum**

(b) Explain why the wall of the left ventricle is thicker than the wall of the right ventricle.

.....

.....

..... [2]

(c) Describe two differences between the structure of the aorta and the pulmonary vein.

1. ....

.....

2. ....

..... [2]

(d) The heart muscle is supplied with blood through the coronary arteries. Explain why a blockage in these arteries can cause a heart attack.

.....

.....

..... [2]

2 (a) Fig. 2.1 shows a simple circuit containing two identical lamps.

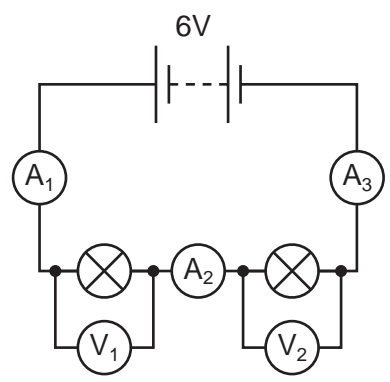

Fig. 2.1

Ammeter **A<sub>1</sub>** reads 0.15 A.

Write down the readings on

ammeter **A<sub>2</sub>**, .....

ammeter **A<sub>3</sub>**, .....

voltmeter **V<sub>1</sub>**, .....

voltmeter **V<sub>2</sub>**, .....

[2]

(b) (i) The electrical output from a power station is at 25 000 V. The voltage is stepped up to 400 000 V by a transformer. The number of turns on the primary coil is 20 000.

Calculate the number of turns on the secondary coil.

State the formula that you use and show your working.

formula used

working

..... turns [3]

(ii) Explain why transformers require an a.c. input.

.....  
.....  
..... [2]

3 Fig. 3.1 shows a car in motion. The energy which is needed to make the car move from burning a mixture of air and fuel in the engine.

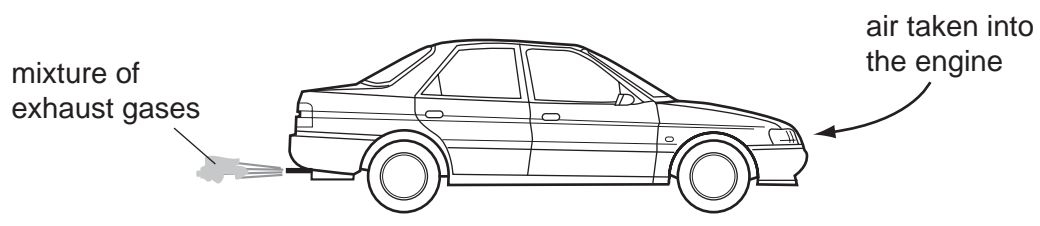

Fig. 3.1

(a) Air is a mixture of gases.

Describe **one** difference between a **mixture** of two gases and a **compound** formed from two gases.

.....

.....

..... [1]

(b) Gasoline, a mixture of hydrocarbons, is a fuel used in car engines. When gasoline is burnt most of it undergoes complete combustion, but a small amount is incompletely combusted.

(i) Name **one** gaseous substance and **one** solid substance which are formed as the result of incomplete combustion.

gaseous substance .....

solid substance ..... [2]

(ii) Two chemical tests could be carried out on the mixture of exhaust gases to show that much of the gasoline fuel was undergoing **complete** combustion.

Describe these chemical tests.

1. ....

.....

.....

2. ....

.....

..... [4]

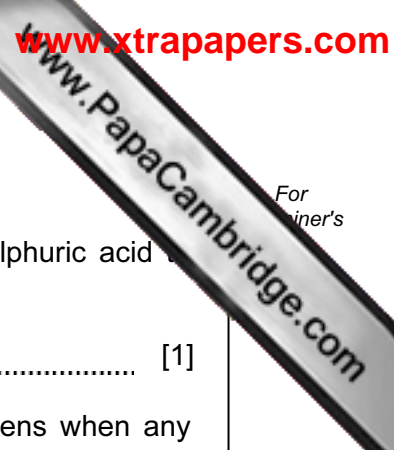

(c) The car battery contains sulphuric acid.

(i) State the chemical formula of an alkali which would neutralise sulphuric acid to produce the salt, potassium sulphate.

..... [1]

(ii) Write a balanced equation involving ions which shows what happens when any acid is neutralised by any alkali.

..... [2]

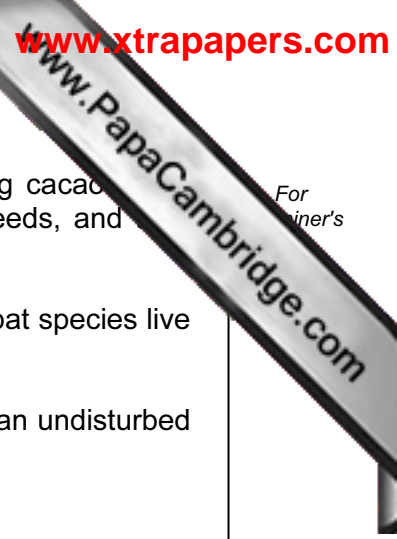

- 4 In Mexico, some areas of tropical rainforest have been cleared for growing cacao. Beans from cacao trees are used for making chocolate. The beans are seeds, and they develop from fertilised flowers.

Bats are flying mammals that feed on insects, fruit or nectar. Many different bat species live in tropical rainforests.

Table 4.1 shows information about the numbers of plants and bats found in an undisturbed tropical rainforest and in a cacao plantation.

**Table 4.1**

habitat	number of different species of plants	number of different species of bats	number of bat species found <b>only</b> in that habitat
in undisturbed rainforest	93	27	14
in cacao plantation	77	21	1

- (a) Explain how the data in Table 4.1 show that the rainforest has a higher species diversity than the cacao plantation.

.....

.....

..... [2]

- (b) Using the data in Table 4.1, suggest **one** reason, other than species diversity, why leaving some areas of tropical rainforests undisturbed is important for the conservation of bats.

.....

..... [1]

- (c) Using the information provided, suggest how bats could help to increase the yield of beans from a cacao plantation.

.....

.....

..... [2]

(d) Farmers allow other plants to grow underneath the cacao trees.

Explain how this could help to reduce soil erosion.

.....  
.....  
..... [2]

(e) Cacao trees are also grown in Africa. A fungus causes a disease called black pod, which can destroy up to 80% of the crop.

Farmers have found that the pesticides they have been using are no longer effective against this fungus. They have tried biological control instead, using a different fungus that attacks the black pod fungus.

Fig. 4.1 shows the percentage of pods affected by black pod when no treatment was given and when the trees were treated with the biological control fungus.

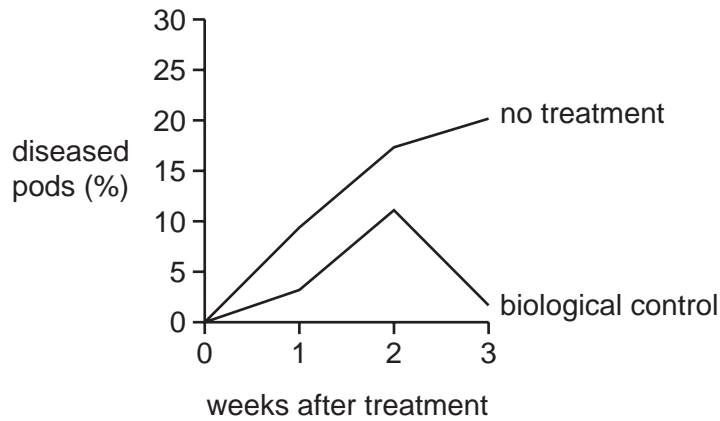

Fig. 4.1

(i) Describe the effect of the biological control fungus on black pod disease.

.....  
.....  
..... [2]

(ii) Suggest reasons for the changes in the number of diseased pods over the three week period when the biological control fungus was used.

.....  
.....  
..... [2]

5 (a) A car is being driven along the road.

Fig. 5.1 shows the speed-time graph for the journey.

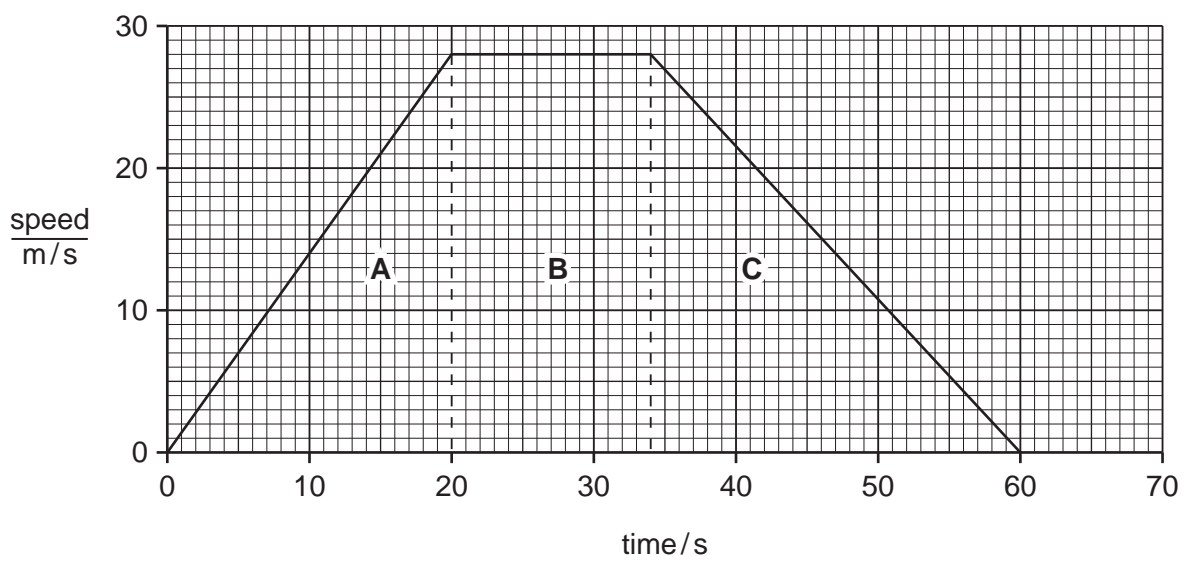

Fig. 5.1

(i) Which section of the graph, **A**, **B**, or **C**, represents a constant speed?

Explain your answer.

.....  
..... [1]

(ii) Calculate the acceleration of the car during the first 20 seconds.

Show your working.

..... [2]



(iii) The car and driver have a total mass of 1400 kg.

Calculate the force that produced the acceleration over the first 20 seconds.

State the formula that you use and show your working.

formula used

working

..... [2]

(iv) Calculate the total distance travelled over 60 seconds.

Show your working.

..... [2]

**Question 5 is continued on page 10, overleaf.**

(b) The car travels over a long bridge. The bridge is made in sections, with gaps between each section. The gaps are filled with rubber.

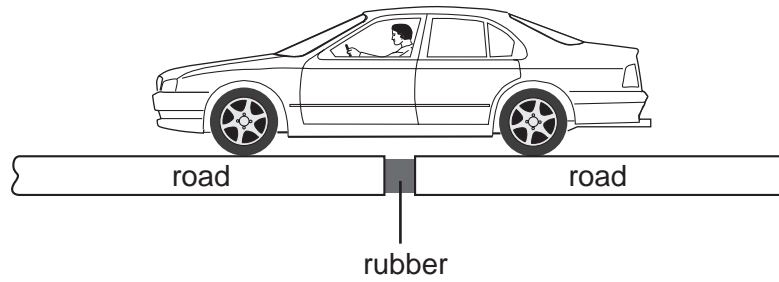

Suggest why

(i) these gaps are left,

.....  
 ..... [1]

(ii) these gaps are filled with rubber.

.....  
 ..... [1]

(c) The heated rear windscreen of the car contains nine wires, connected in parallel, each with a resistance of 10 ohms.

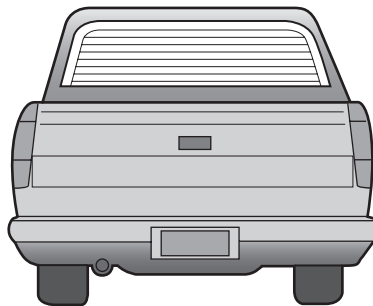

Is the combined resistance of all the wires more or less than 10 ohms?

Explain your answer.

.....  
 ..... [1]

6 (a) Fig. 6.1 shows a metal reacting in cold water.

A gas is produced very quickly during the reaction, and when this gas is tested it burns with a squeaky pop.

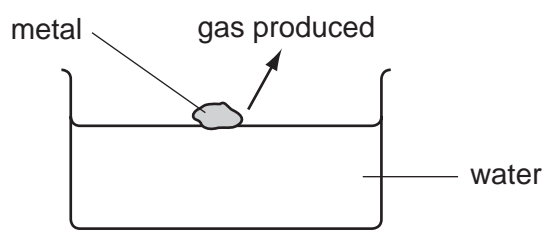

Fig. 6.1

Suggest the name of a metal which would react like the one shown in Fig. 6.1.

Explain your answer.

name of metal .....

explanation .....

.....

..... [3]

(b) A student carried out an experiment into the rusting of steel nails. She used 31.0 g of new nails in her experiment.

After some days the nails had become rusty and the student re-weighed them.

Her result is shown in Fig. 6.2.

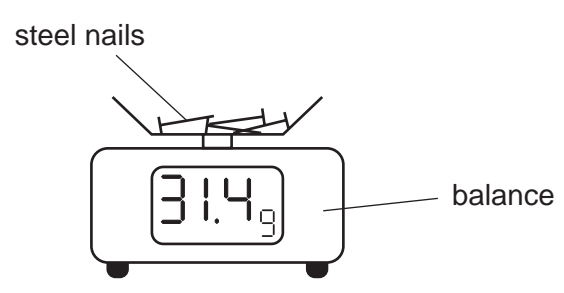

Fig. 6.2

(i) State the type of chemical reaction which takes place when steel rusts.

..... [1]

(ii) Explain the increase in mass which the student found in her experiment.

.....

.....

..... [2]

- 7 All metabolic reactions in animals and plants are catalysed by enzymes. Enzymes from plants usually have a lower optimum temperature than enzymes from humans.

Fig. 7.1 shows the rate of activity of a human enzyme at different temperatures.

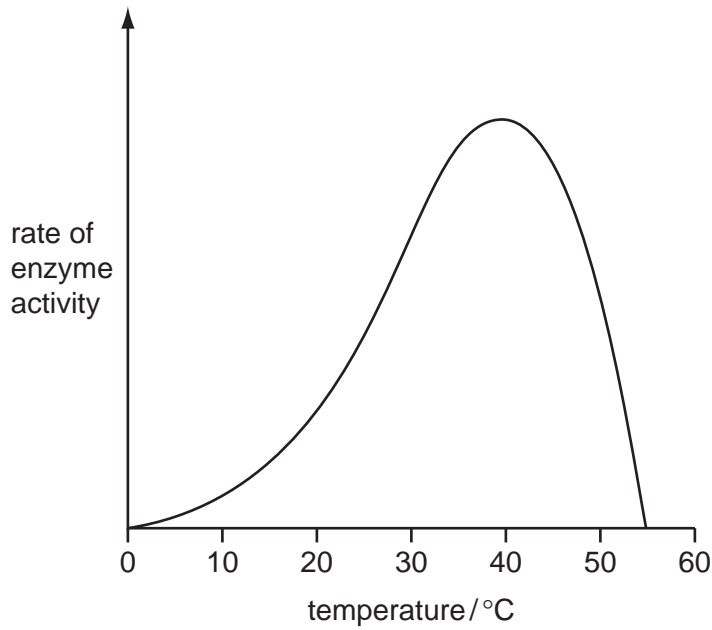

Fig. 7.1

- (a) On Fig. 7.1, sketch a curve to show the rate of activity of a plant enzyme. [1]

- (b) Explain the reasons for the shape of the curve for the human enzyme.

.....

.....

.....

.....

.....

.....

..... [4]

- (c) Suggest why it is advantageous to a plant to have enzymes that have a lower optimum temperature than human enzymes.

.....

..... [1]

8 Gamma radiation and visible light are two regions of the electromagnetic spectrum.

(a) (i) Name another region of the electromagnetic spectrum that is used for cooking food.

..... [1]

(ii) All electromagnetic waves travel at the same speed in a vacuum.

State this speed.

..... [1]

(iii) State **one** way in which the waves in different regions of the electromagnetic spectrum differ from each other.

..... [1]

(b) Alpha, beta and gamma are three types of radiation emitted during radioactive decay.

(i) State the meaning of the term *radioactive decay*.

..... [1]

(ii) Name a suitable detector for these three types of radiation.

..... [1]

(iii) State clearly what happens to each of the types of radiation when they pass between metal plates that have opposite electrical charges.

alpha .....

.....

beta .....

.....

gamma .....

..... [3]

(iv) Describe how these types of radiation can be dangerous to the human body.

.....

.....

..... [2]

9 The apparatus in Fig. 9.1 can be used to break down the compound lead bromide elements.

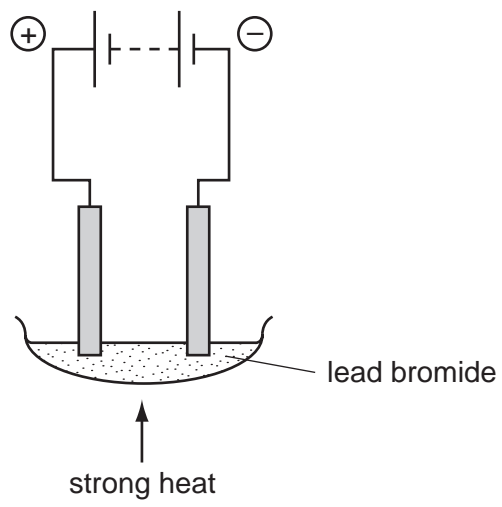

Fig. 9.1

(a) (i) Name the non-metallic element which is produced in this process.

..... [1]

(ii) Explain why the lead bromide shown in Fig. 9.1 has to be heated strongly in order for the process to work.

.....  
.....  
..... [2]

(b) Lead bromide has the chemical formula  $PbBr_2$ . Bromide ions are  $Br^-$ .

(i) Deduce the charge on lead ions in lead bromide.

Show how you obtained your answer.

..... [2]

(ii) Deduce the total number of electrons in one bromide ion.

Explain how you obtained your answer.

number of electrons .....

explanation .....

.....

..... [2]

(c) A process similar to that in Fig. 9.1 is used in the chemical industry to produce the important element chlorine.

(i) Complete the bonding diagram below to show how the outer electrons are arranged in a chlorine molecule.

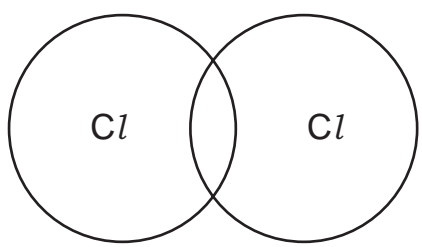

[2]

(ii) Chlorine reacts with the element silicon to form silicon chloride. In silicon chloride molecules, one silicon atom is bonded to four chlorine atoms.

Deduce a balanced symbolic equation for the reaction between silicon and chlorine.

..... [2]

**DATA SHEET**  
**The Periodic Table of the Elements**

		Group																							
		I	II	III	IV	V	VI	VII	VIII	IX	X														
		1 <b>H</b> Hydrogen 1																							
7	9	<b>Li</b> Lithium 3	<b>Be</b> Beryllium 4																						
23	24	<b>Na</b> Sodium 11	<b>Mg</b> Magnesium 12																						
39	40	<b>K</b> Potassium 19	<b>Ca</b> Calcium 20	51 <b>V</b> Vanadium 23	48 <b>Ti</b> Titanium 22	45 <b>Sc</b> Scandium 21	59 <b>Co</b> Cobalt 27	56 <b>Fe</b> Iron 26	55 <b>Mn</b> Manganese 25	59 <b>Ni</b> Nickel 28	64 <b>Cu</b> Copper 29	65 <b>Zn</b> Zinc 30	70 <b>Ga</b> Gallium 31	73 <b>Ge</b> Germanium 32	75 <b>As</b> Arsenic 33	79 <b>Se</b> Selenium 34	80 <b>Br</b> Bromine 35	84 <b>Kr</b> Krypton 36							
85	88	<b>Rb</b> Rubidium 37	<b>Sr</b> Strontium 38	93 <b>Nb</b> Niobium 41	91 <b>Zr</b> Zirconium 40	89 <b>Y</b> Yttrium 39	103 <b>Rh</b> Rhodium 45	101 <b>Ru</b> Ruthenium 44	106 <b>Pd</b> Palladium 46	108 <b>Ag</b> Silver 47	112 <b>Cd</b> Cadmium 48	115 <b>In</b> Indium 49	119 <b>Sn</b> Tin 50	122 <b>Sb</b> Antimony 51	128 <b>Te</b> Tellurium 52	127 <b>I</b> Iodine 53	131 <b>Xe</b> Xenon 54								
133	137	<b>Cs</b> Caesium 55	<b>Ba</b> Barium 56	181 <b>Ta</b> Tantalum 73	178 <b>Hf</b> Hafnium 72	139 <b>La</b> Lanthanum 57	184 <b>W</b> Tungsten 74	190 <b>Os</b> Osmium 76	195 <b>Pt</b> Platinum 78	197 <b>Au</b> Gold 79	201 <b>Hg</b> Mercury 80	204 <b>Tl</b> Thallium 81	207 <b>Pb</b> Lead 82	209 <b>Bi</b> Bismuth 83	210 <b>Po</b> Polonium 84	210 <b>At</b> Astatine 85	210 <b>Rn</b> Radon 86								
	226	<b>Fr</b> Francium 87	<b>Ra</b> Radium 88																						
	227			† <b>Ac</b> Actinium 89																					
												*58-71 Lanthanoid series		†90-103 Actinoid series											
												140 <b>Ce</b> Cerium 58	141 <b>Pr</b> Praseodymium 59	144 <b>Nd</b> Neodymium 60	150 <b>Sm</b> Samarium 62	152 <b>Eu</b> Europium 63	157 <b>Gd</b> Gadolinium 64	159 <b>Tb</b> Terbium 65	162 <b>Dy</b> Dysprosium 66	165 <b>Ho</b> Holmium 67	167 <b>Er</b> Erbium 68	169 <b>Tm</b> Thulium 69	173 <b>Yb</b> Ytterbium 70	175 <b>Lu</b> Lutetium 71	
												232 <b>Th</b> Thorium 90	238 <b>Pa</b> Protactinium 91	238 <b>U</b> Uranium 92	238 <b>Np</b> Neptunium 93	238 <b>Pu</b> Plutonium 94	238 <b>Am</b> Americium 95	238 <b>Cm</b> Curium 96	238 <b>Bk</b> Berkelium 97	238 <b>Cf</b> Californium 98	238 <b>Es</b> Einsteinium 99	238 <b>Fm</b> Fermium 100	238 <b>Md</b> Mendelevium 101	238 <b>No</b> Nobelium 102	238 <b>Lr</b> Lawrencium 103

a = relative atomic mass

X = atomic symbol

b = proton (atomic) number

Key

a	<b>X</b>	b
---	----------	---

The volume of one mole of any gas is 24 dm<sup>3</sup> at room temperature and pressure (r.t.p.).

Permission to reproduce items where third-party owned material protected by copyright is included has been sought and cleared where possible. Every reasonable effort has been made by the publisher (UCLES) to trace copyright holders, but if any items requiring clearance have unwittingly been included, the publisher will be pleased to make amends at the earliest possible opportunity.

University of Cambridge International Examinations is part of the Cambridge Assessment Group. Cambridge Assessment is the brand name of University of