



Cambridge IGCSE™

CANDIDATE
NAME

CENTRE
NUMBER

--	--	--	--	--

CANDIDATE
NUMBER

--	--	--	--



CO-ORDINATED SCIENCES

0654/41

Paper 4 Theory (Extended)

October/November 2020

2 hours

You must answer on the question paper.

No additional materials are needed.

INSTRUCTIONS

- Answer **all** questions.
- Use a black or dark blue pen. You may use an HB pencil for any diagrams or graphs.
- Write your name, centre number and candidate number in the boxes at the top of the page.
- Write your answer to each question in the space provided.
- Do **not** use an erasable pen or correction fluid.
- Do **not** write on any bar codes.
- You may use a calculator.
- You should show all your working and use appropriate units.

INFORMATION

- The total mark for this paper is 120.
- The number of marks for each question or part question is shown in brackets [].
- The Periodic Table is printed in the question paper.

This document has **28** pages. Blank pages are indicated.

- 1 (a) Mammals have a double circulatory system. Fish have a single circulatory system.

Fig. 1.1 shows the circulatory system of a fish and the circulatory system of a mammal.

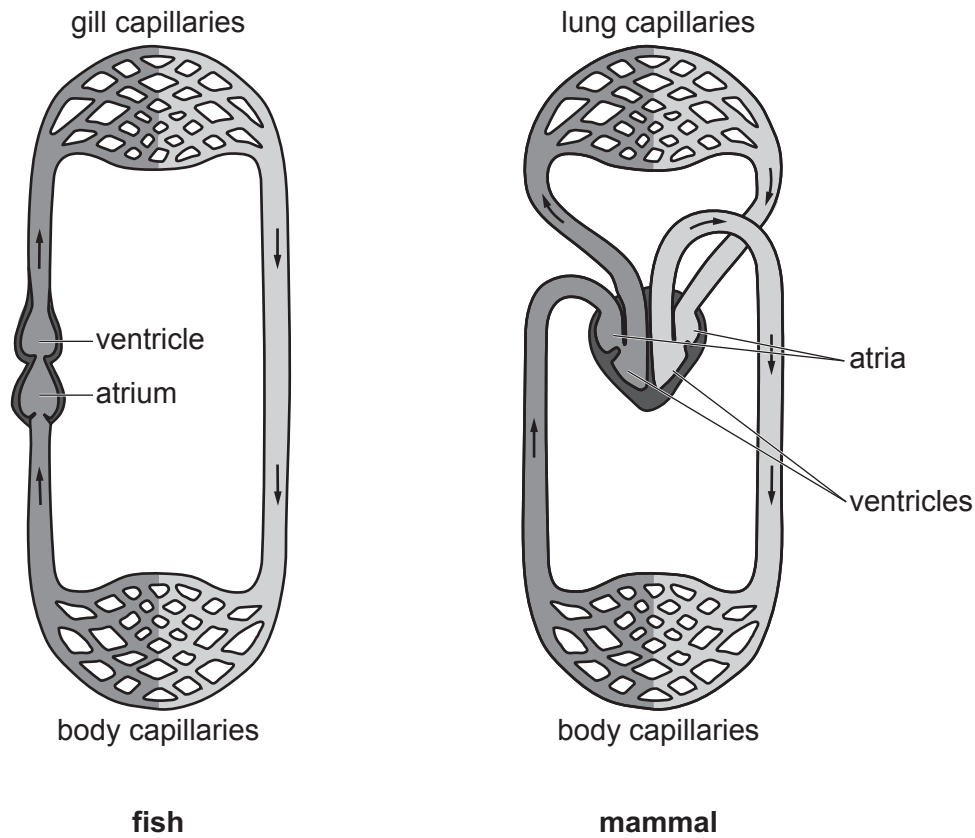

Fig. 1.1

- (i) Use Fig. 1.1 to describe **two** ways the circulatory system of a fish is different from the circulatory system of a mammal.

1

.....

2

.....

[2]

- (ii) Explain **one** advantage of having a double circulatory system.

.....

.....

.....

.....

[2]

- (b) Table 1.1 shows the diameter and the thickness of the wall of two different blood vessels in humans.

Table 1.1

	type of blood vessel	
	aorta	vena cava
diameter of blood vessel /mm	25	30
thickness of wall /mm	2.0	1.5

- (i) Calculate the difference in thickness of the wall of the aorta and the vena cava.

.....mm [1]

- (ii) Explain why the walls of the aorta and the vena cava need to be of different thicknesses.

.....

 [2]

- (c) Red blood cells transport oxygen around the body.

- (i) Describe **two** ways red blood cells are adapted for their function.

1

 2
 [2]

- (ii) State **two other** major components of blood.

1
 2 [2]

[Total: 11]

- 2 Paper chromatography is used to find out whether a fruit drink, **D**, contains a harmful food colouring, **X**.

Spots of substances **D** and **X**, and spots of three non-harmful food colourings, **A**, **B**, and **C**, are placed on chromatography paper.

Fig. 2.1 shows the results of the chromatography experiment.

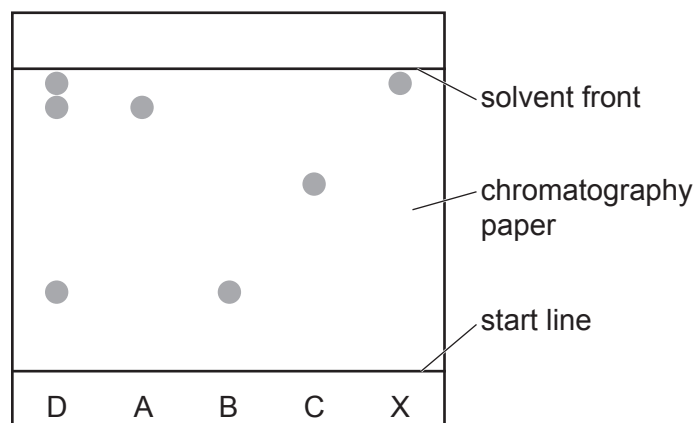

Fig. 2.1

- (a) State why the start line is drawn using pencil, rather than using ink.

.....
 [1]

- (b) State whether the fruit drink **D** is a pure substance or a mixture.

Explain your answer.

D is a

explanation

..... [1]

- (c) State whether the fruit drink contains the harmful food colouring **X**.

Explain your answer.

.....
 [1]

5

(d) Calculate the R_f value of the spot from food colouring A.

R_f value = [2]

(e) Tartrazine is a synthetic orange-yellow food colouring.

Tartrazine has a relative molecular mass, M_r , of 534.

A tartrazine dye solution has a concentration of 84 g/dm^3 .

Calculate the concentration of the tartrazine dye in mol/dm^3 .

concentration = mol/dm^3 [2]

[Total: 7]

- 3 (a) A car travels along a road at 8 m/s.

Describe the difference between the terms *speed* and *velocity*.

.....

.....

..... [1]

- (b) Some puddles of water have formed on the road.

Explain, in terms of water molecules, how the rate of evaporation of water from a puddle is affected by the strength of the wind blowing across the puddle.

.....

.....

.....

..... [2]

- (c) The car battery has an electromotive force (e.m.f.) of 12 V.

State what is meant by *electromotive force*.

.....

.....

..... [2]

- (d) Fig. 3.1 shows part of the lighting circuit for the car. Two lamps, L_1 and L_2 , each have a resistance of $16\ \Omega$.

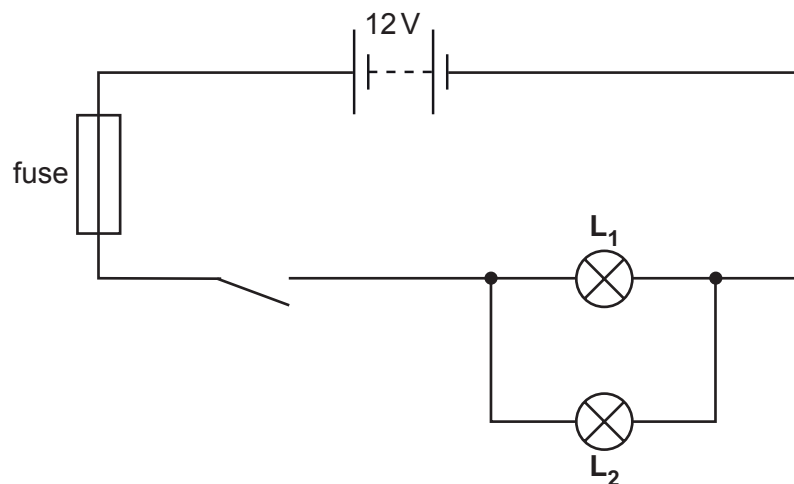

Fig. 3.1

- (i) When the switch is closed the current in the fuse is 1.5A.

Determine the current in L_1 .

current = A [1]

- (ii) State **one** reason why the lamps are connected as shown in Fig. 3.1 and **not** in series.

Explain your answer.

.....
.....
..... [2]

- (e) Modern cars use optical fibres to transfer information using visible light rays.

Fig. 3.2 shows a ray of light entering an optical fibre.

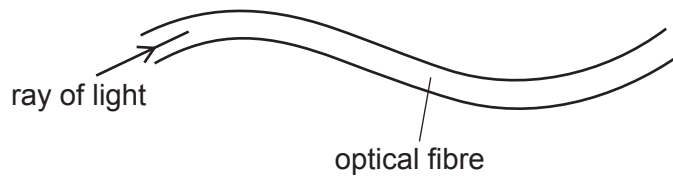

Fig. 3.2

- (i) Explain why the ray of light is able to stay inside the optical fibre. You may draw on Fig. 3.2 if it helps your answer.

.....
.....
.....
..... [2]

- (ii) Visible light rays are transverse waves.

Draw labelled diagrams to show the difference between a transverse wave and a longitudinal wave.

[2]

[Total: 12]

[Turn over

- 4 (a) A student investigates what effect immersing grapes in distilled water and concentrated salt solution has on the mass of the grapes.

The student measures the mass of a grape before and after immersion.

The results are shown in Table 4.1.

Table 4.1

	mass before immersion/g	mass after immersion/g	percentage change in mass
distilled water	5.0	5.1	+2.0
concentrated salt solution	5.1	4.8	-5.9

Explain why the grape placed in distilled water increased in mass.

.....

.....

.....

.....

.....

.....

..... [3]

- (b) The student repeated the investigation by immersing a grape in 100% pure grape juice.

This time there was **no** change in mass.

Suggest why there was no change in mass.

.....

..... [1]

(c) Fig. 4.1 shows diagrams of plant cells that have been immersed in different concentrations of solutions.

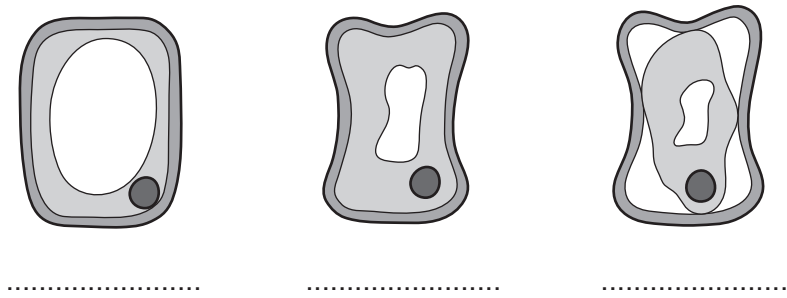

Fig. 4.1

Each cell can be described using one of these words:

- flaccid
- plasmolysed
- turgid.

Write on the lines underneath each cell in Fig. 4.1, the correct word to describe the cell. [1]

(d) State **two** structures in plant cells that are **not** found in animal cells.

1

2

[2]

[Total: 7]

- 5 A scientist investigates the reaction between calcium carbonate and dilute hydrochloric acid.

Carbon dioxide gas is given off during the reaction.

The scientist measures the mass of the flask and its contents every 30 seconds during the experiment.

Fig. 5.1 shows the apparatus the scientist uses.

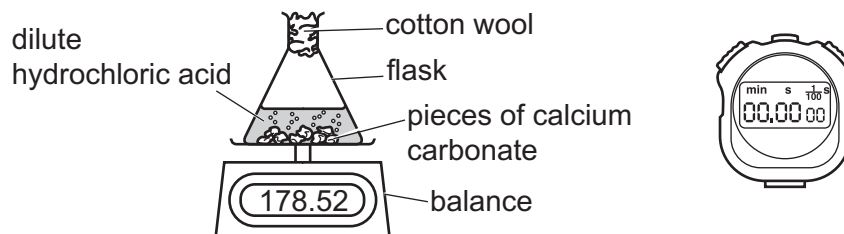

Fig. 5.1

After every reading, the scientist calculates the mass of carbon dioxide gas given off.

The scientist repeats the experiment using the same amount of calcium carbonate and dilute hydrochloric acid.

This time he uses **warm** dilute hydrochloric acid instead of cold dilute hydrochloric acid.

Fig. 5.2 shows the scientist's results.

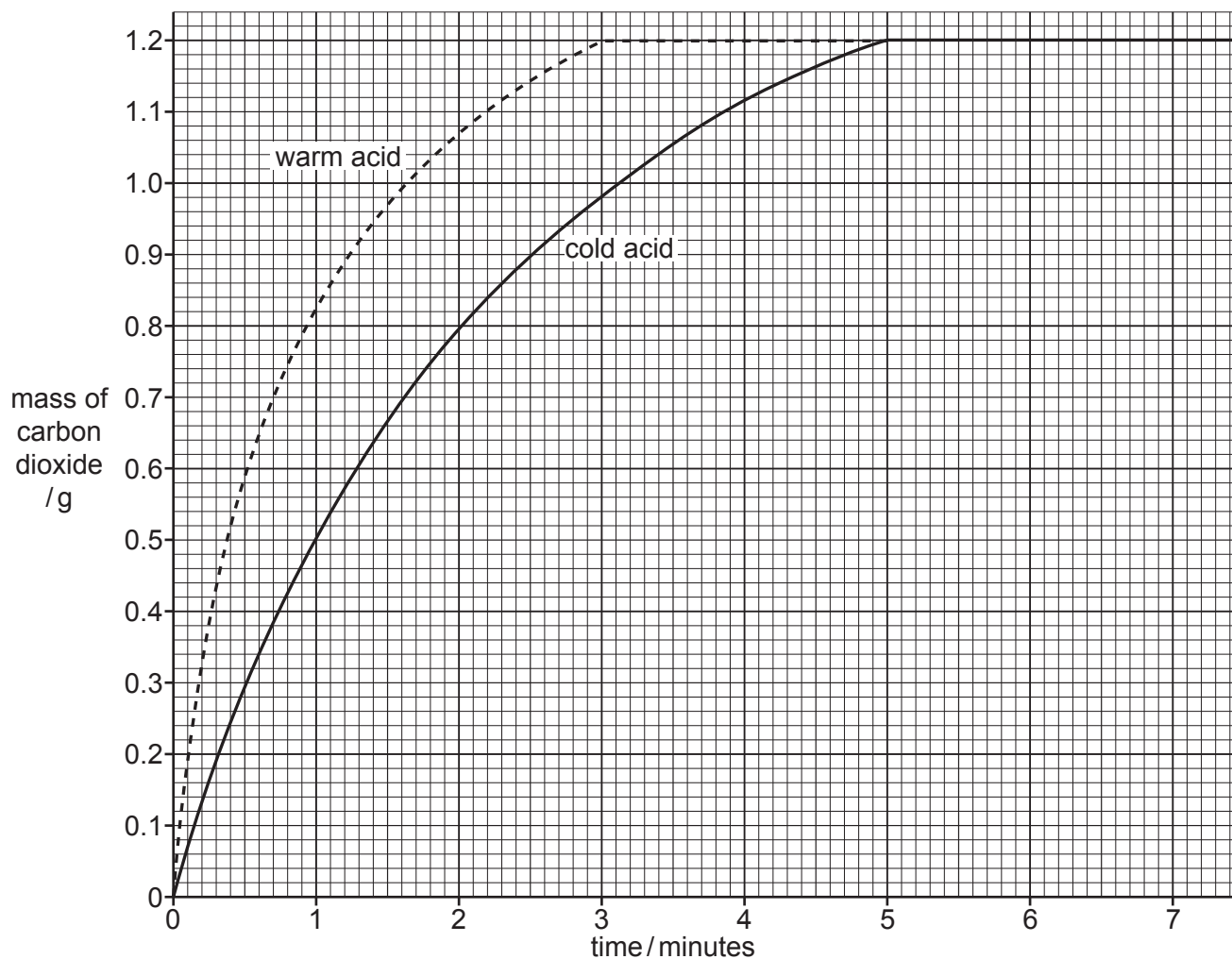

Fig. 5.2

(a) (i) Use Fig. 5.2 to state the mass of carbon dioxide made after 2.5 minutes using **cold** acid.
..... [1]

(ii) Warm acid reacts faster with calcium carbonate than cold acid.
Explain why both reactions make 1.2g of carbon dioxide gas.
.....
..... [1]

(iii) Calculate the volume occupied by 1.2g of carbon dioxide gas at 25 °C.
The molar gas volume at 25 °C is 24 dm³.
[A_r: C, 12; O, 16]

volume = dm³ [3]

(b) The reaction with warm acid is faster than the reaction with cold acid.
Explain why reactions are faster at higher temperatures.
Explain your answer in terms of collisions between particles.
.....
.....
..... [3]

(c) State **two** other processes that produce carbon dioxide.
1
2 [2]

[Total: 10]

6 (a) A farmer drives his tractor at a constant speed.

Fig. 6.1 shows four forces **P**, **Q**, **R** and **S** acting on the tractor.

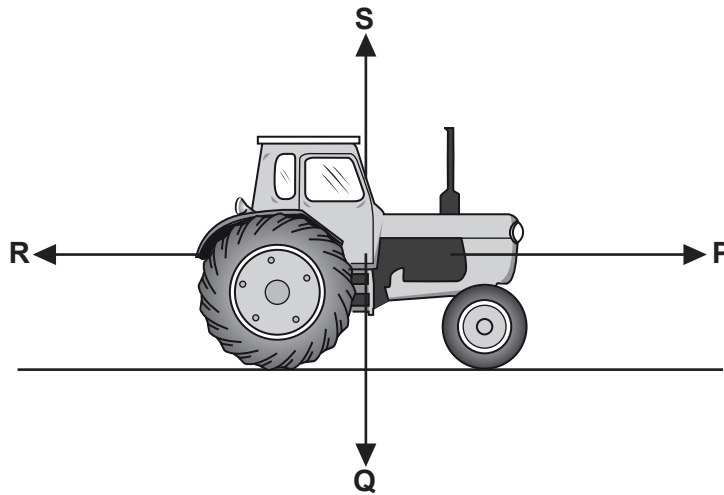

Fig. 6.1

(i) State the letter corresponding to the gravitational force acting on the tractor.

.....

[1]

(ii) Force **P** is 1500 N.

State the value of force **R**.

Explain your answer.

force **R** = N

explanation

.....

[2]

(b) The tractor accelerates.

The force causing this acceleration is 4200 N.

The weight of the tractor is 35000 N.

The gravitational field strength g is 10 N/kg.

Calculate the acceleration of the tractor.

acceleration = m/s² [3]

(c) The tractor has very wide tyres as shown in Fig. 6.2.



Fig. 6.2

The tractor sinks into the soil if the pressure acting on the ground is too large.

Explain why having wider tyres reduces the pressure of the tractor on the ground.

.....
.....
..... [2]

(d) The farmer lifts a bucket of water from a well.

The bucket of water has a weight of 120N and is lifted through a vertical distance of 18m.

Calculate the work done.

work done = J [2]

[Total: 10]

7 (a) Fig. 7.1 shows a food web in a desert.

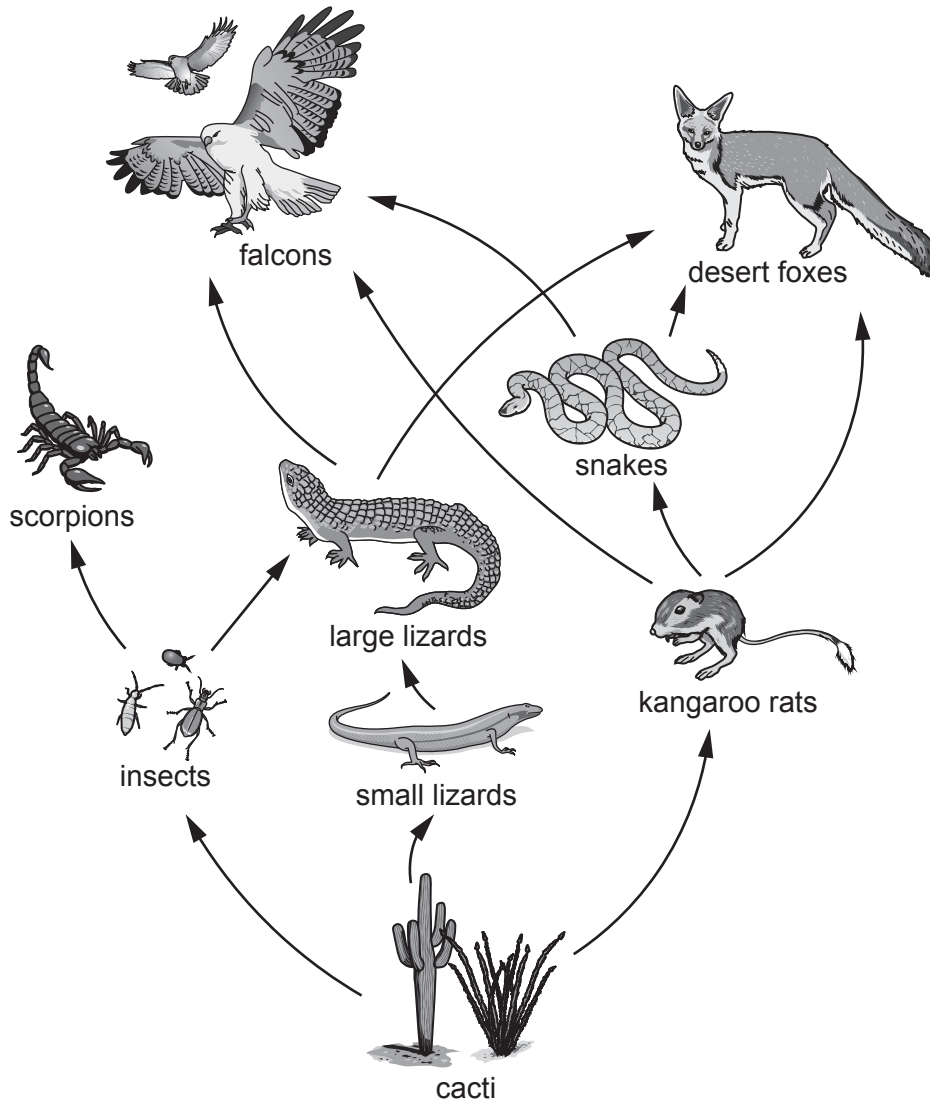

Fig. 7.1

(i) Construct a food chain containing scorpions.

..... [2]

(ii) State the number of trophic levels in the food chain in your answer to (a)(i).

..... [1]

(iii) Explain why desert foxes can be described as feeding at the third **and** fourth trophic level.

.....

 [2]

(iv) Suggest reasons why the population of desert foxes is much smaller than the population of kangaroo rats.

.....
.....
.....
..... [2]

(b) Fig. 7.2 is a photograph of a falcon and its owner.



Fig. 7.2

Falcons have developed several adaptations that have been useful for their survival. More recently falcons have been selectively bred for their speed and hunting ability.

(i) Complete the definition of *adaptation*.

Adaptation is the process, resulting from natural selection, by which populations become more suited to their over many

..... [2]

(ii) Describe **three** ways in which selective breeding is different from natural selection.

1

.....

2

.....

3

.....

[3]

[Total: 12]

[Turn over

8 Methanol, CH_3OH , is made by reacting carbon dioxide with hydrogen.

Water is also made in this reaction.

(a) (i) Write the balanced symbol equation for this reaction.

..... [2]

(ii) This reaction is an exothermic reaction.

State the meaning of the word *exothermic*.

.....

..... [1]

(iii) On Fig. 8.1, complete the energy level diagram for an exothermic reaction.

Label the **activation energy** and the **energy change** on your diagram.

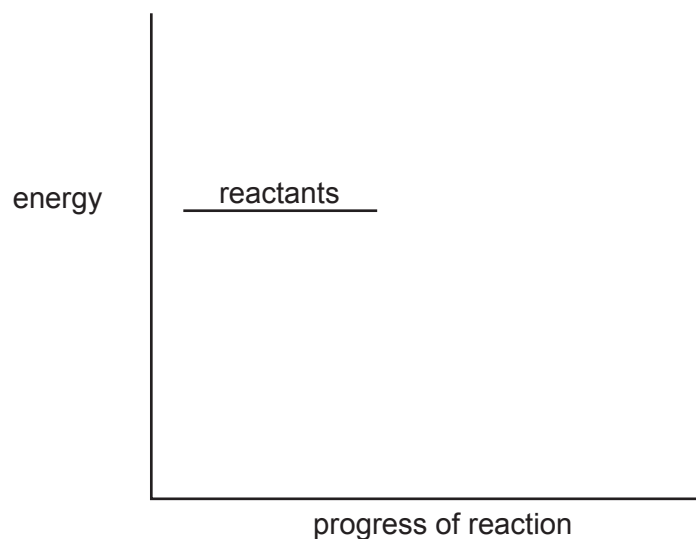

Fig. 8.1

[3]

(b) Methanol, CH₃OH, is a **covalent** molecule.

Draw a dot-and-cross diagram to show the bonding in methanol.

Show only the outer shell electrons.

[2]

(c) Methanol is **not** a hydrocarbon.

Explain why.

.....
..... [1]

[Total: 9]

- 9 (a) A student cycles to school.

Fig. 9.1 shows a speed–time graph for the journey.

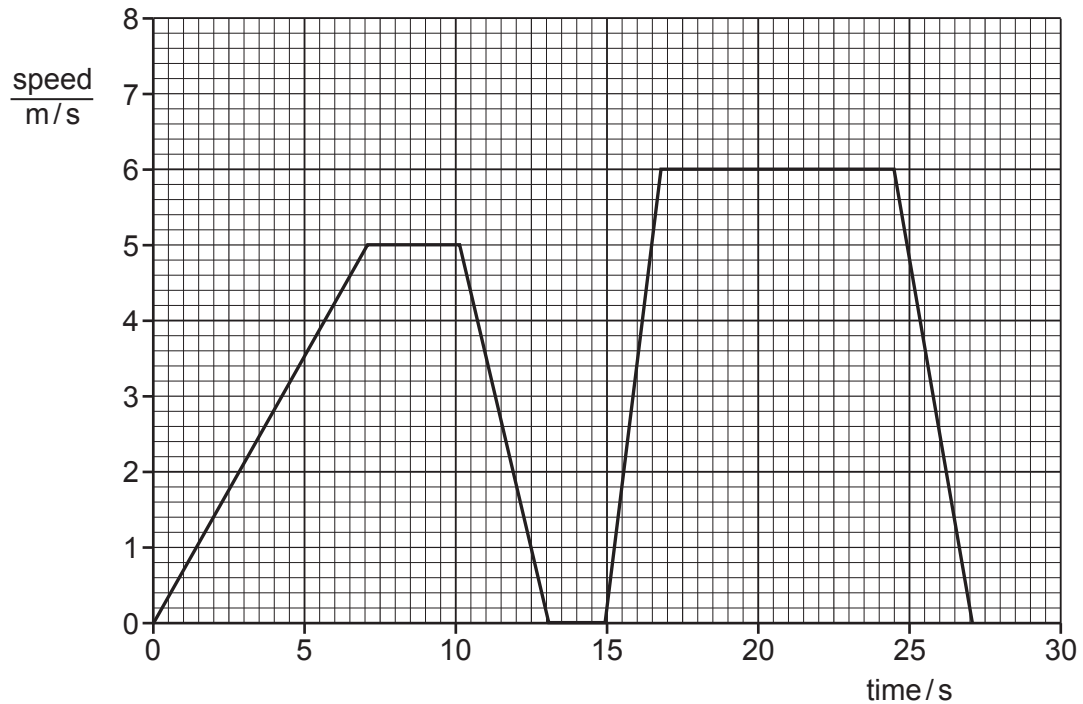

Fig. 9.1

- (i) Draw an **X** on Fig. 9.1 to identify the part of the journey where there is maximum acceleration.

[1]

- (ii) Calculate the acceleration of the student and bicycle at time = 5 s.

acceleration = m/s² [2]

- (b) At school, the student is asked how she would accurately measure the width of one of the brake cables on her bicycle.

Name a measuring device suitable for measuring very small distances accurately.

..... [1]

- (c) The student watches her teacher set up an experiment to detect the β -radiation emitted by a radioactive source, strontium-90 (Sr).

When strontium-90 decays it produces an isotope of yttrium (Y).

- (i) Use the correct nuclide notation to complete the symbol equation for this decay process.



- (ii) State **one** difference between the behaviour of β -particles and γ -rays in an electric field.

.....
..... [1]

[Total: 8]

10 (a) Fig. 10.1 is a photograph of wind-pollinated flowers.

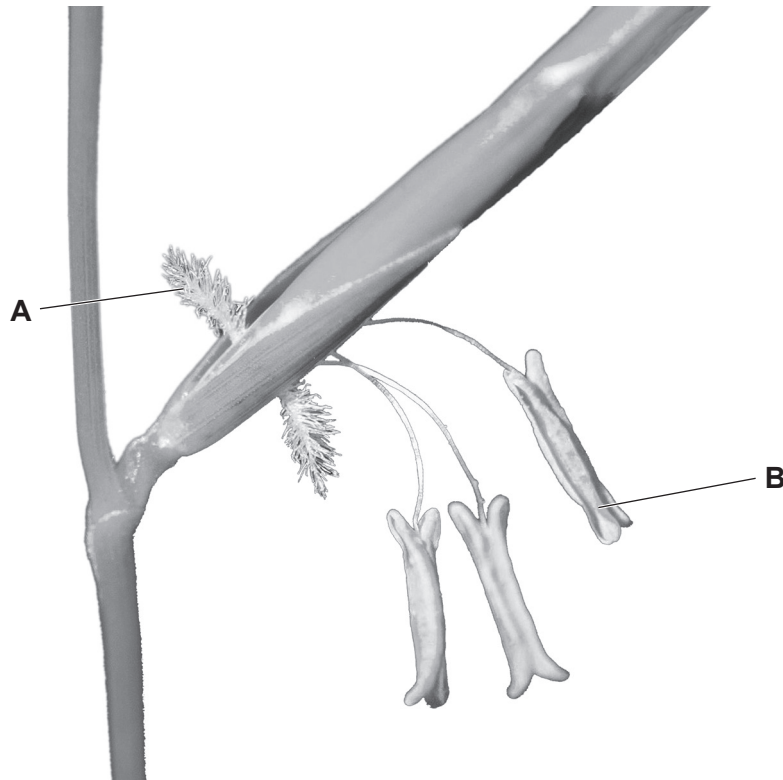

Fig. 10.1

Identify the parts labelled **A** and **B** in Fig. 10.1.

A

B

[2]

(b) Table 10.1 compares the features of pollen from an insect-pollinated flower and a wind-pollinated flower.

Complete Table 10.1 to show the features of pollen from an insect-pollinated flower and a wind-pollinated flower.

Table 10.1

feature	type of flower pollen	
	insect-pollinated	wind-pollinated
relative size		
relative mass		
appearance of surface		

[3]

- (c) Describe **two** ways the petals of an insect-pollinated flower are different from the petals of a wind-pollinated flower.

1

2

[2]

- (d) Flowers are the reproductive structures in plants.

Plants and human females both contain ovaries.

- (i) State the function of the ovary in plants.

..... [1]

- (ii) State the function of the ovary in humans.

..... [1]

- (e) Plants can reproduce asexually or sexually.

A cell is formed by fusion of the nuclei of two gametes during sexual reproduction.

State the name of this cell.

..... [1]

[Total: 10]

- 11 (a) Concentrated aqueous sodium chloride can be electrolysed using inert electrodes.

Fig. 11.1 shows the electrolysis.

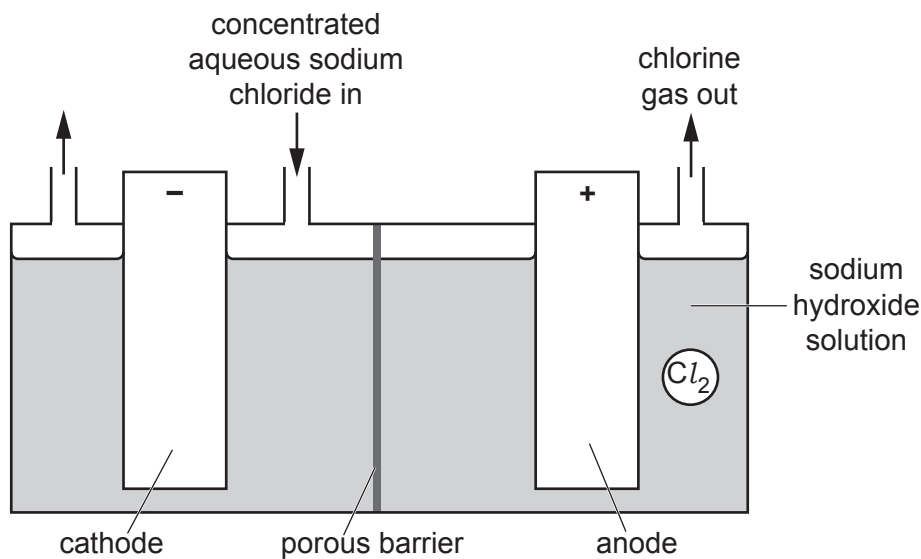

Fig. 11.1

Chlorine gas is made at the anode.

- (i) Explain why chlorine gas is made at the anode.

.....

.....

.....

..... [2]

- (ii) State the name of the product at the cathode.

..... [1]

- (iii) Explain why the electrodes used must be *inert* electrodes.

.....

..... [1]

- (b) **Molten** sodium chloride can also be electrolysed.

Sodium is made at the cathode.

Write the balanced ionic half-equation for the reaction at the cathode.

Include state symbols.

..... [2]

(c) Sodium chloride has a lattice structure.

Draw a **labelled** diagram of the lattice structure of sodium chloride.

[2]

[Total: 8]

12 (a) Fig. 12.1 shows a laptop computer and charger.

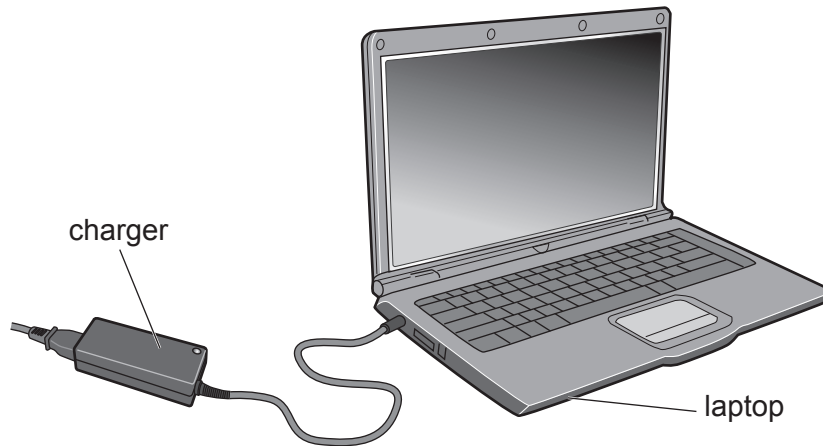

Fig. 12.1

The charger contains a transformer.

The input voltage across the primary coil is 250 V.

The primary coil has 5000 turns.

The output voltage from the secondary coil is 19 V.

(i) Explain why this transformer is called a step-down transformer.

.....
 [1]

(ii) Calculate the number of turns on the secondary coil.

number of turns = [2]

(b) The laptop computer has a rechargeable battery.

The battery takes 2 hours to charge fully when a voltage of 19 V is used with a current of 1.1 A.

Calculate the energy transferred during the 2 hours.

energy = J [3]

(c) Fig. 12.2 shows the laptop computer being closed by a force of 12 N.

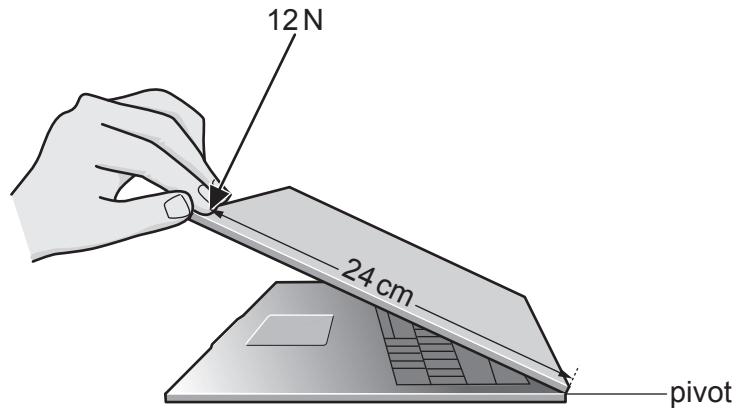

Fig. 12.2

Calculate the moment of the force about the pivot.

moment = Nm [2]

(d) The microprocessor in the laptop generates large quantities of thermal energy. The thermal energy must be removed so that the microprocessor does not overheat.

Fig. 12.3 shows a heat sink placed in contact with the microprocessor.

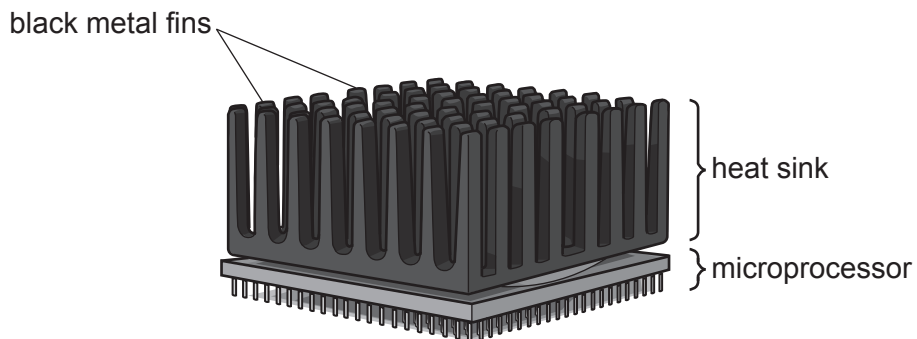

Fig. 12.3

Thermal energy is conducted from the microprocessor into the metal fins of the heat sink.

Suggest and explain **two** ways in which the design of the heat sink allows thermal energy to be removed efficiently from the heat sink.

- 1
-
- 2
-

[2]

[Total: 10]

[Turn over

13 Ammonia, NH_3 , is used in the manufacture of nitrogen-containing fertilisers.

(a) Explain why nitrogen-containing fertilisers are important.

..... [1]

(b) Ammonia is made in the Haber process.

Fig. 13.1 shows stages in the Haber process.

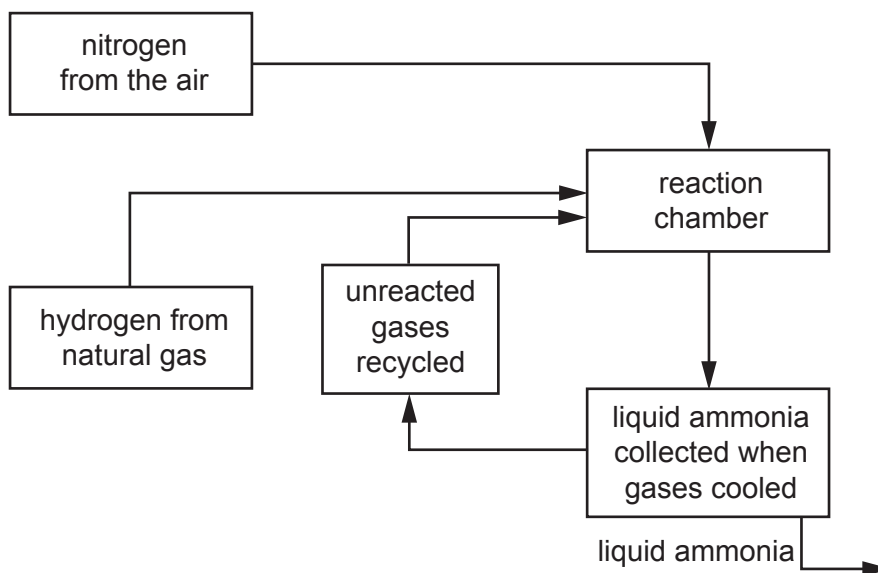

Fig. 13.1

(i) Write a balanced symbol equation for the formation of ammonia in the Haber process.

..... [2]

(ii) Suggest a suitable pressure to use in the reaction chamber.

..... [1]

(iii) Explain why:

- an iron catalyst
- a temperature of 450°C

are used in the reaction chamber.

iron catalyst

.....

temperature of 450°C

.....

[2]

[Total: 6]

The Periodic Table of Elements

Group																	
I	II											III	IV	V	VI	VII	VIII
3 Li lithium 7	4 Be beryllium 9	Key atomic number atomic symbol name relative atomic mass										5 B boron 11	6 C carbon 12	7 N nitrogen 14	8 O oxygen 16	9 F fluorine 19	10 Ne neon 20
11 Na sodium 23	12 Mg magnesium 24											1 H hydrogen 1	13 Al aluminium 27	14 Si silicon 28	15 P phosphorus 31	16 S sulfur 32	17 Cl chlorine 35.5
19 K potassium 39	20 Ca calcium 40	21 Sc scandium 45	22 Ti titanium 48	23 V vanadium 51	24 Cr chromium 52	25 Mn manganese 55	26 Fe iron 56	27 Co cobalt 59	28 Ni nickel 59	29 Cu copper 64	30 Zn zinc 65	31 Ga gallium 70	32 Ge germanium 73	33 As arsenic 75	34 Se selenium 79	35 Br bromine 80	36 Kr krypton 84
37 Rb rubidium 85	38 Sr strontium 88	39 Y yttrium 89	40 Zr zirconium 91	41 Nb niobium 93	42 Mo molybdenum 96	43 Tc technetium —	44 Ru ruthenium 101	45 Rh rhodium 103	46 Pd palladium 106	47 Ag silver 108	48 Cd cadmium 112	49 In indium 115	50 Sn tin 119	51 Sb antimony 122	52 Te tellurium 128	53 I iodine 127	54 Xe xenon 131
55 Cs caesium 133	56 Ba barium 137	57–71 lanthanoids	72 Hf hafnium 178	73 Ta tantalum 181	74 W tungsten 184	75 Re rhenium 186	76 Os osmium 190	77 Ir iridium 192	78 Pt platinum 195	79 Au gold 197	80 Hg mercury 201	81 Tl thallium 204	82 Pb lead 207	83 Bi bismuth 209	84 Po polonium —	85 At astatine —	86 Rn radon —
87 Fr francium —	88 Ra radium —	89–103 actinoids	104 Rf rutherfordium —	105 Db dubnium —	106 Sg seaborgium —	107 Bh bohrium —	108 Hs hassium —	109 Mt meitnerium —	110 Ds darmstadtium —	111 Rg roentgenium —	112 Cn copernicium —	114 Fl flerovium —	116 Lv livermorium —	—	—	—	—

57 La lanthanum 139	58 Ce cerium 140	59 Pr praseodymium 141	60 Nd neodymium 144	61 Pm promethium —	62 Sm samarium 150	63 Eu europium 152	64 Gd gadolinium 157	65 Tb terbium 159	66 Dy dysprosium 163	67 Ho holmium 165	68 Er erbium 167	69 Tm thulium 169	70 Yb ytterbium 173	71 Lu lutetium 175
89 Ac actinium —	90 Th thorium 232	91 Pa protactinium 231	92 U uranium 238	93 Np neptunium —	94 Pu plutonium —	95 Am americium —	96 Cm curium —	97 Bk berkelium —	98 Cf californium —	99 Es einsteinium —	100 Fm fermium —	101 Md mendelevium —	102 No nobelium —	103 Lr lawrencium —

The volume of one mole of any gas is 24 dm³ at room temperature and pressure (r.t.p.).