



UNIVERSITY OF CAMBRIDGE INTERNATIONAL EXAMINATIONS  
General Certificate of Education  
Advanced Subsidiary Level and Advanced Level

**DESIGN AND TECHNOLOGY**

**9705/11**

Paper 1

**October/November 2009**

**3 hours**

Additional Materials: Answer Booklet/A4 Paper  
A3 Drawing Paper (3 sheets)  
Extra sheets of A3 drawing paper for candidates who have used up both sides of their 3 sheets  
A range of design drawing equipment

**READ THESE INSTRUCTIONS FIRST**

If you have been given an Answer Booklet, follow the instructions on the front cover of the Booklet.

Write your name, Centre number and candidate number on all the work you hand in.

Write in dark blue or black pen.

You may use a soft pencil, or coloured pencils/pens as appropriate, for any diagrams, graphs or rough working.

Do not use staples, paper clips, highlighters, glue or correction fluid.

**Section A**

Answer **one** question on the Answer Booklet/A4 Paper provided.

**Section B**

Answer **one** question on the Answer Booklet/A4 Paper provided.

**Section C**

Answer **one** question on plain A3 paper.

Use **both** sides of the paper.

You may request additional sheets of A3 paper, but only if you have used up both sides of each of the 3 sheets provided.

You are advised to spend **30 minutes** on each of Sections A and B and **2 hours** on Section C.

At the end of the examination, fasten all your work securely together.

The number of marks is given in brackets [ ] at the end of each question or part question.

All dimensions are in millimetres.

This document consists of **11** printed pages and **1** blank page.



\*  
3  
2  
2  
9  
8  
0  
1  
3  
1  
9  
\*

Section A

Answer **one** question from this section on the Answer Booklet/A4 paper provided.

1 Fig. 1 shows a spatula, for using on a barbecue, which is to be made in a school workshop.

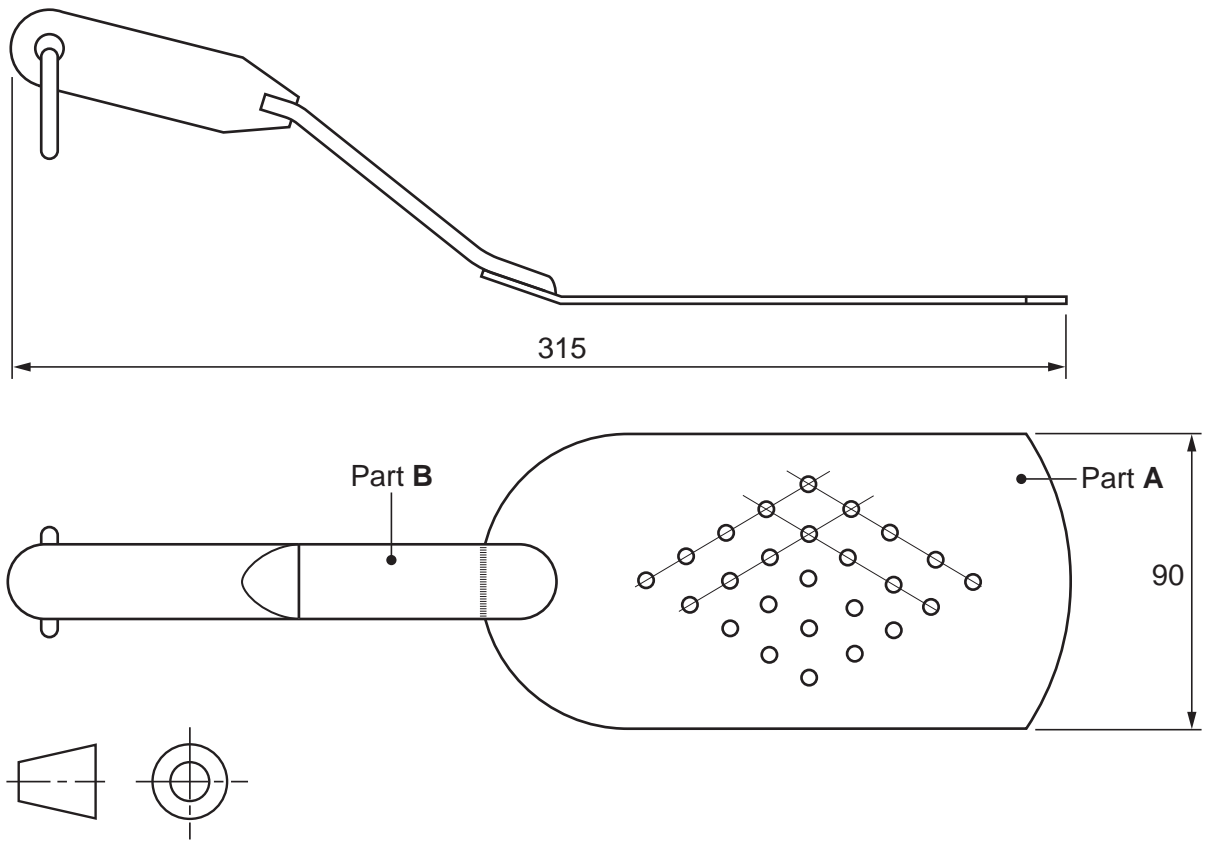

Fig. 1

- (a) Name a suitable sheet material for making part **A** of the design and give **one** reason for your choice. [2]
- (b) Use notes and sketches to describe:
  - (i) how part **A** could be cut out and the edges of the sheet material finished and polished; [6]
  - (ii) how the holes in part **A** could be marked out with the aid of a template and then drilled; [6]
  - (iii) how part **A** could be joined to part **B**. [6]

You must give details about the tools, equipment and processes involved and the safety precautions that have to be undertaken at each stage.

2 Fig. 2 shows a storage rack for books and magazines, which is to be made in a school workshop.

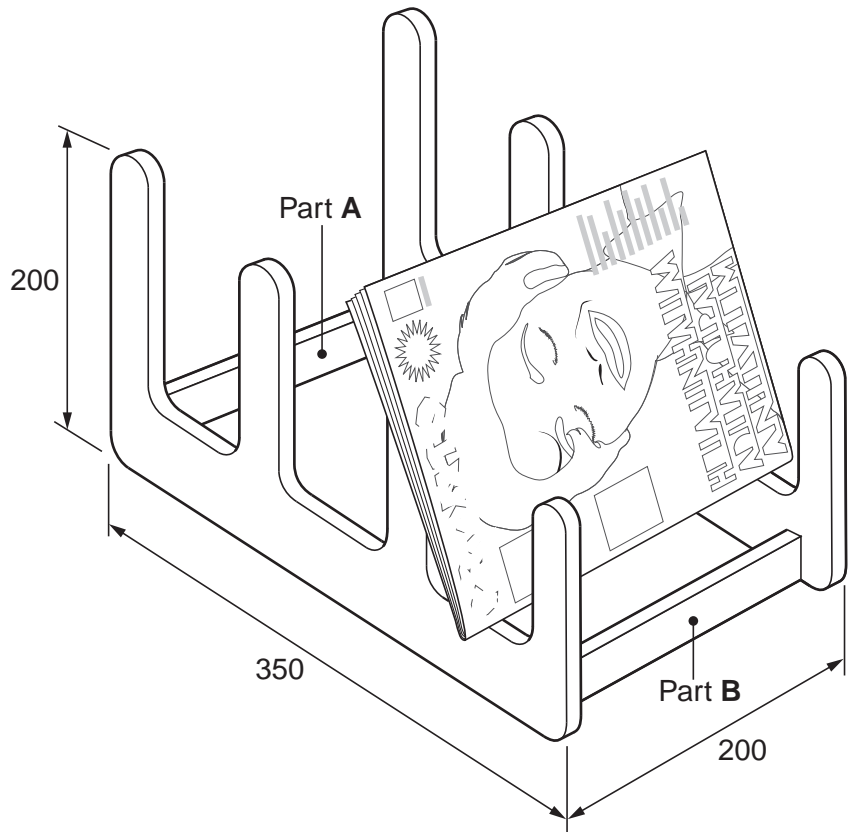

Fig. 2

- (a) Name a suitable manufactured wooden sheet material for making the rack and give **one** reason for your choice. [2]
  
- (b) Use notes and sketches to describe:
  - (i) how the sides could be cut out and the edges of the sheet material finished and smoothed; [6]
  - (ii) how the sides could be joined to parts **A** and **B** so that they could be easily removed; [6]
  - (iii) how a painted finish could be applied to the rack. [6]

You must give details about the tools, equipment and processes involved and the safety precautions that have to be taken at each stage.

3 Fig. 3 shows a leaflet holder, which is to be made in a school workshop.

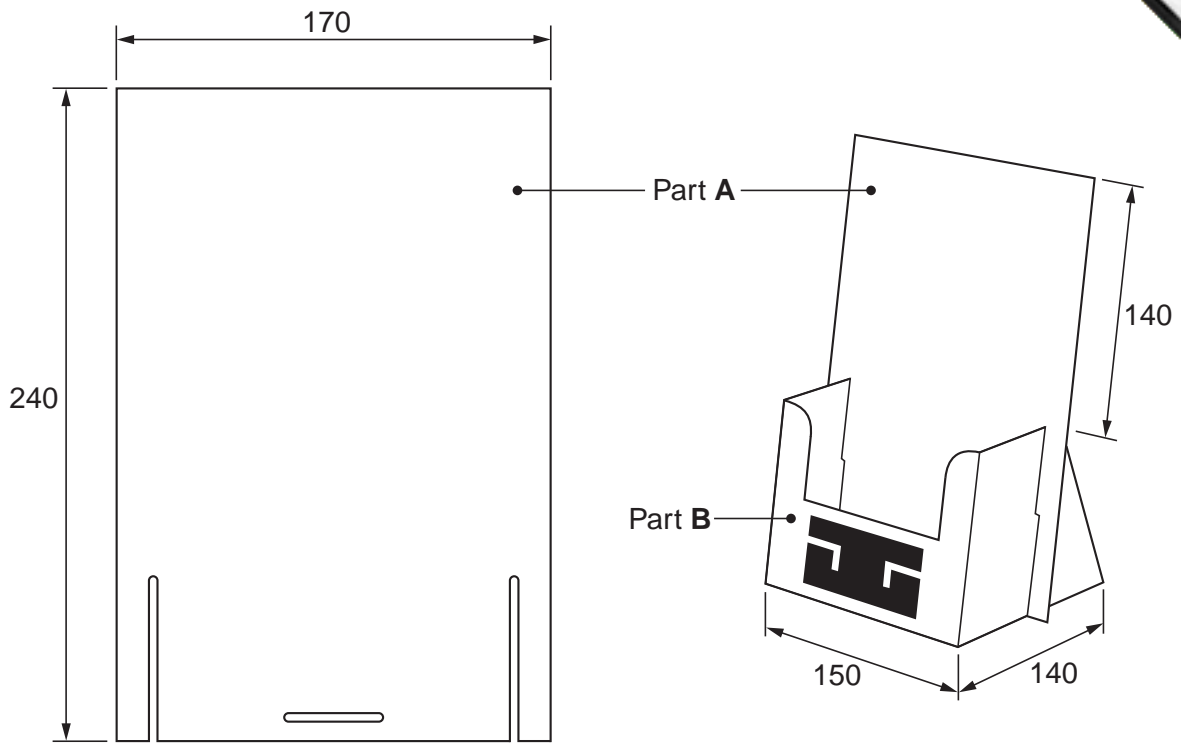

Fig. 3

(a) State a suitable thickness of card for making the leaflet holder and give **one** reason for your choice. [2]

(b) The leaflet holder is to be made in two parts, **A** and **B**.

Use notes and sketches to describe:

(i) how the two parts could slot together without the use of glue or other additional materials; [6]

(ii) how a stencil could be made and used to add the logo to the front of the leaflet holder. [6]

(c) Sketch, to an appropriate scale, the development (net) required to make part **B**. [6]

You must give details about the tools, equipment and processes involved and the safety precautions that may have to be taken at each stage.

Section B

Answer **one** question from this section on the Answer Booklet/A4 paper provided.

4 Fig. 4 shows a range of frame designs that could be used for an office desk.

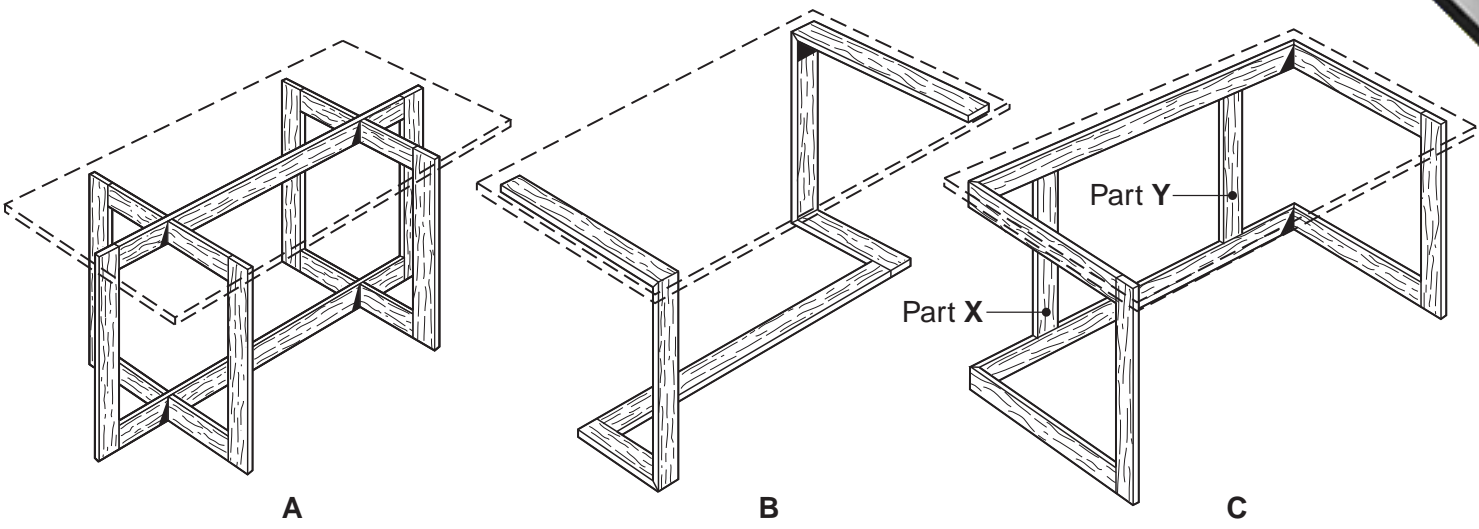

Fig. 4

- (a) Explain the purpose of parts **X** and **Y** in design **C**. [2]
- (b) Describe **two** problems with design **B**. [4]
- (c) Explain how the two problems that you have identified in **(b)** could be overcome. [6]
- (d) Discuss how a designer would need to consider ergonomics and anthropometric data when designing an office desk. Your answer should:
  - (i) analyse the given situation and identify three relevant issues raised by the question; [3]
  - (ii) explain why you consider these three issues to be relevant; [3]
  - (iii) contain specific examples/evidence as support for your conclusions. [2]

5 Fig. 5 shows a design for packaging an MP3 player.

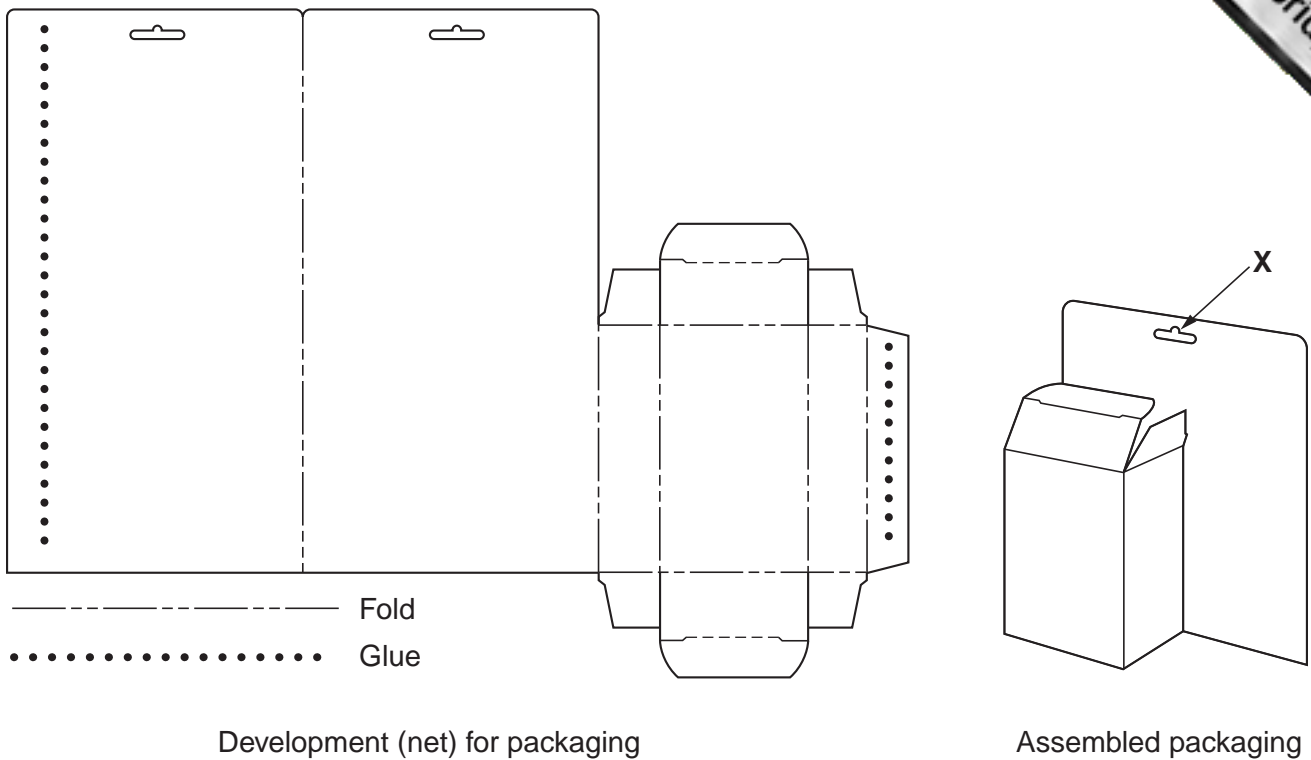
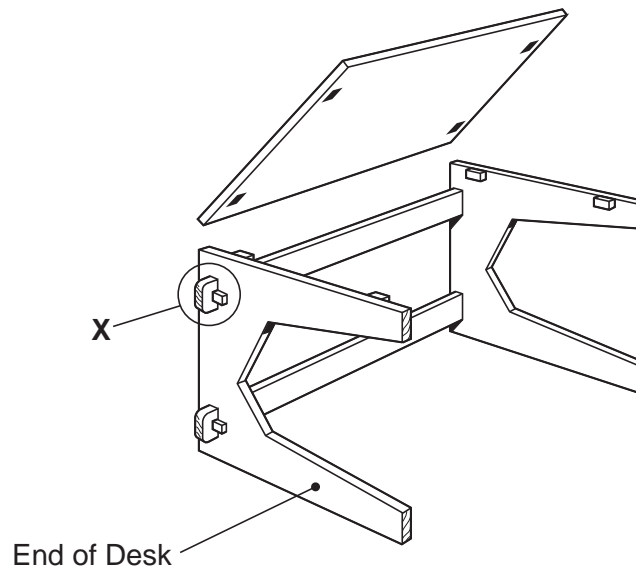

Fig. 5

- (a) Explain the function of the design feature shown at X. [2]
- (b) Describe **two** problems with the design. [4]
- (c) Explain how the two problems you have identified in (b) could be overcome. [6]
- (d) Discuss the merits of using CAD (computer aided design) to model and test designs for packaging on a computer screen before manufacturing begins. Your answer should:
  - (i) analyse the given situation and identify three relevant issues raised by the question; [3]
  - (ii) explain why you consider these issues to be relevant; [3]
  - (iii) contain specific examples/evidence as support for your conclusions. [2]

- 6 Fig. 6 shows a design for a desk, most of which is made from MDF (Medium Density



**Fig. 6**

- (a) Explain the purpose of the design feature shown at X. [2]
- (b) Fig. 7 shows an alternative design that was considered for the end of the desk.

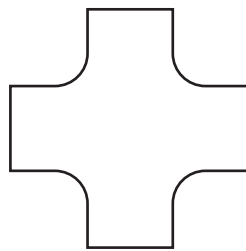

**Fig. 7**

- Describe **two** problems with the design shown in Fig. 7. [4]
- (c) Explain how the two problems you have identified in (b) could be overcome. [6]
- (d) Discuss why manufactured materials such as MDF have, to a large extent, replaced solid timber in the production of furniture. Your answer should:
- (i) analyse the given situation and identify three relevant issues raised by the question; [3]
  - (ii) explain why you consider these three issues to be relevant; [3]
  - (iii) contain specific examples/evidence as support for your conclusions. [2]

Section C

Answer **one** question from this section on the plain A3 paper provided.

You are provided with three sheets of plain A3 paper. You should use **both** sides of the paper. **Each** the five parts **(a) – (e)** of the question that you choose to answer should take up one side of paper.

When you are asked to **develop** a design you must show, using sketches and notes, the development and evaluation of a range of ideas into a single design proposal. The design proposal should be annotated to give details about materials, joining methods and important sizes.

7 Fig. 8 shows an incomplete idea for a drawing desk.

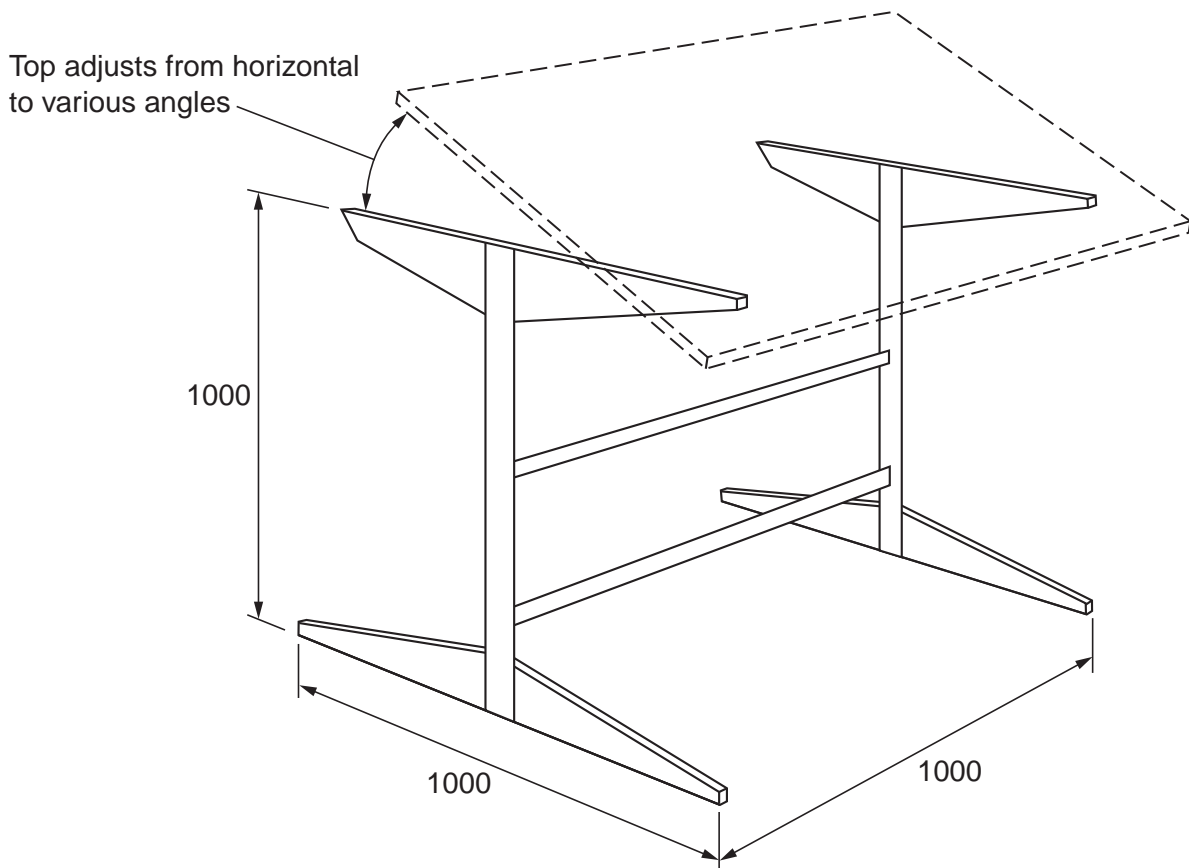

Fig. 8

- (a) Using notes and sketches, **develop** a design which allows the height of the desk to be adjusted so that the top can be fixed at different heights. [16]
- (b) Using notes and sketches, **develop** a design which allows the top of the desk to be adjusted and fixed at different angles. [16]
- (c) Using notes and sketches, **develop** a design for a storage tray to hold drawing equipment which could be attached to the drawing desk. [16]
- (d) Using notes and sketches, **develop** a design which allows the storage tray to be attached and easily removed from the drawing desk. [16]
- (e) Produce a pictorial rendered drawing of the complete desk which shows all of the features that you have designed in (a) – (d). [16]



8 Fig. 9 shows the main structure of an architectural model of a house. Most of the material is made from card.

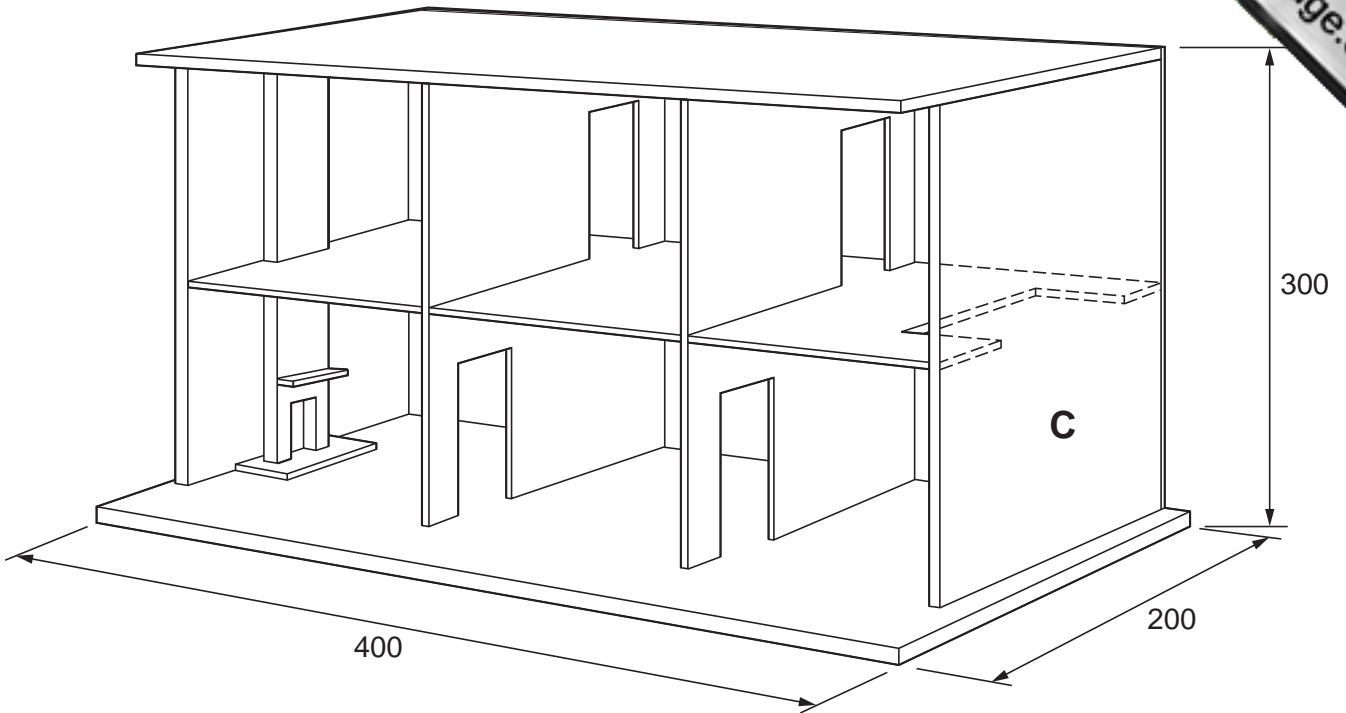

Fig. 9

- (a) Using notes and sketches, **develop** a design for a pitched roof and chimney for the house. It must be possible to remove and replace the roof. [16]
- (b) Using notes and sketches, **develop** a design for a staircase for the house. [16]
- (c) Using notes and sketches, **develop** designs for a front door and the windows to go on the front of the house. The door and windows must open and close. [16]
- (d) Using notes and sketches, **develop** a design for a garage attached to side **C** of the house. The garage door must open and close. [16]
- (e) Produce a pictorial, cut-away rendered drawing of the complete model house which shows all of the features that you have designed in (a) – (d). [16]

9 Figs 10 and 11 show an incomplete idea for a table top game. 12 mm diameter balls are pushed up the chute on the right-hand side of the board. As each ball rolls down the board through various scoring holes and areas that it can go in. Each player has six balls with which to score as many points as possible.

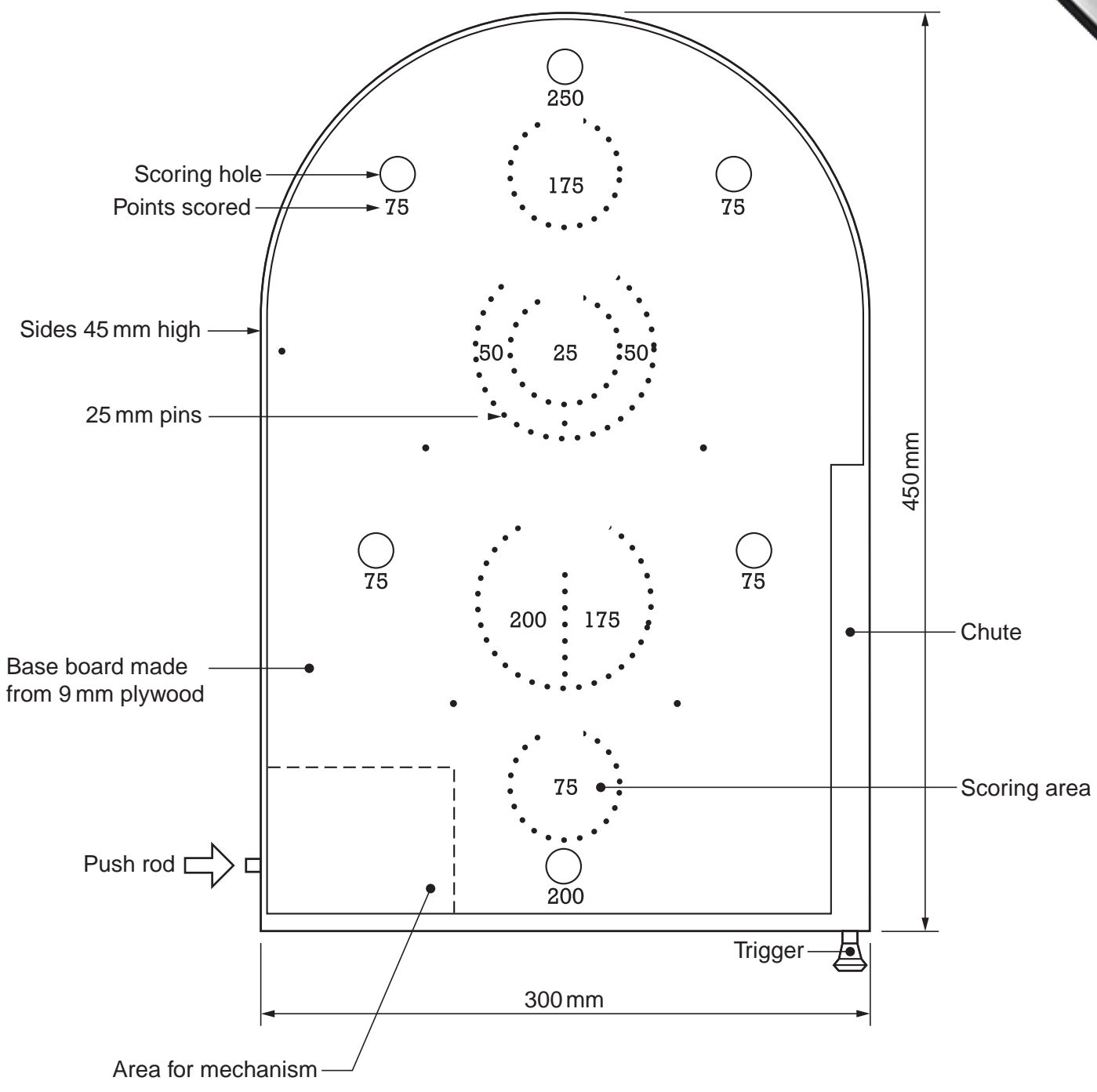

Fig. 10

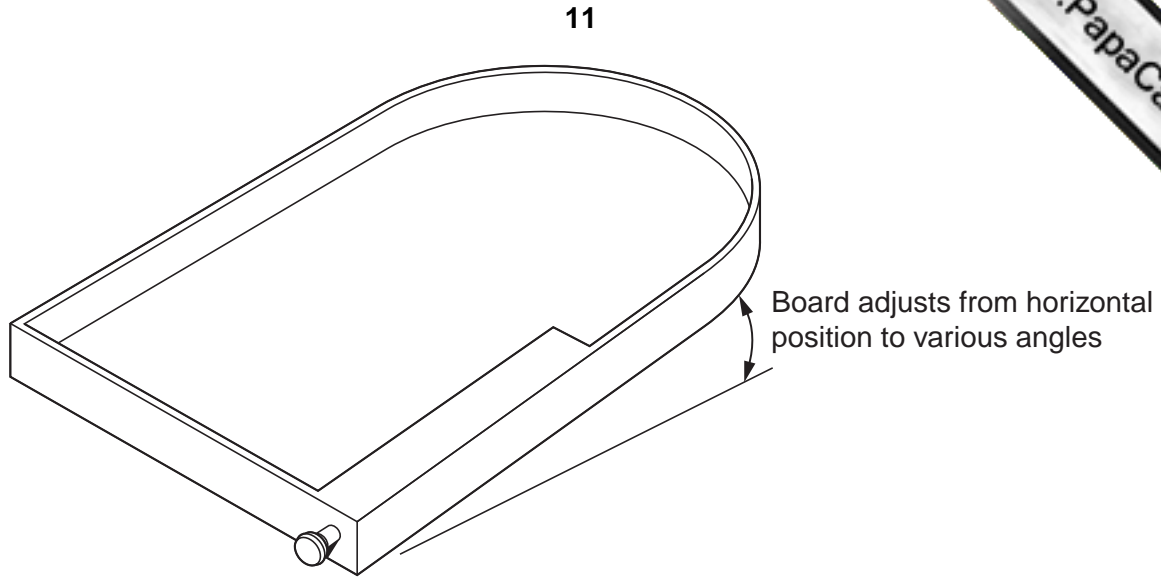

Fig. 11

- (a) At the bottom of the board a mechanism is required to flip balls back up the board to try to score more points. The mechanism is operated by the push rod on the side of the board.  
Using notes and sketches, **develop** a design for the mechanism. [16]
- (b) When the trigger at the bottom of the board is pulled back and released it propels a ball up the chute.  
Using notes and sketches, **develop** a design for the trigger mechanism. [16]
- (c) Using notes and sketches, **develop** a design which allows six 12mm diameter balls to be stored so that they do not fall off the board when it is picked up and carried around. [16]
- (d) Using notes and sketches, **develop** a design which allows the board to be adjusted and fixed at different angles. [16]
- (e) Produce a pictorial, cut-away rendered drawing of the complete game which shows all of the features that you have designed in (a) – (d).  
Do not include the pins and holes. [16]

