



Cambridge International AS & A Level

CANDIDATE
NAME

CENTRE
NUMBER

--	--	--	--	--

CANDIDATE
NUMBER

--	--	--	--



PHYSICS

9702/36

Paper 3 Advanced Practical Skills 2

October/November 2022

2 hours

You must answer on the question paper.

You will need: The materials and apparatus listed in the confidential instructions

INSTRUCTIONS

- Answer **all** questions.
- Use a black or dark blue pen. You may use an HB pencil for any diagrams or graphs.
- Write your name, centre number and candidate number in the boxes at the top of the page.
- Write your answer to each question in the space provided.
- Do **not** use an erasable pen or correction fluid.
- Do **not** write on any bar codes.
- You will be allowed to work with the apparatus for a maximum of 1 hour for each question.
- You should record all your observations in the spaces provided in the question paper as soon as these observations are made.
- You may use a calculator.
- You should show all your working and use appropriate units.

INFORMATION

- The total mark for this paper is 40.
- The number of marks for each question or part question is shown in brackets [].

For Examiner's Use	
1	
2	
Total	

This document has **16** pages. Any blank pages are indicated.

You may not need to use all of the materials provided.

1 In this experiment, you will investigate the oscillations of a pendulum.

- (a) (i) • Assemble the apparatus as shown in Fig. 1.1 with the top nail held securely in the cork by the clamp. Check that the rod can swing freely.

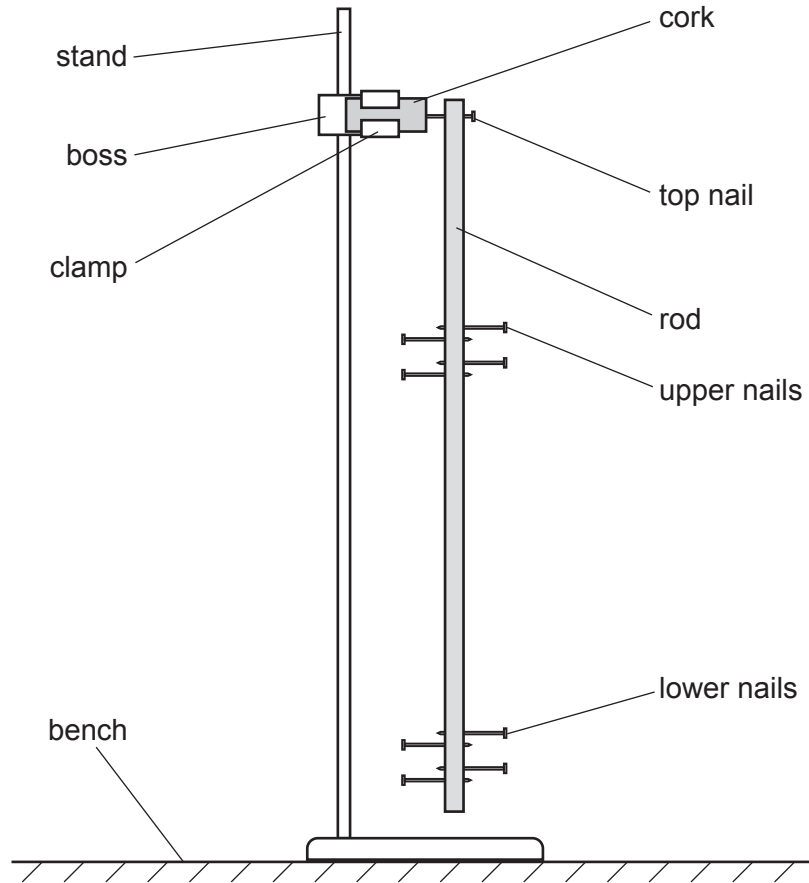

Fig. 1.1

- Slot masses onto the upper and lower nails as shown in Fig. 1.2.

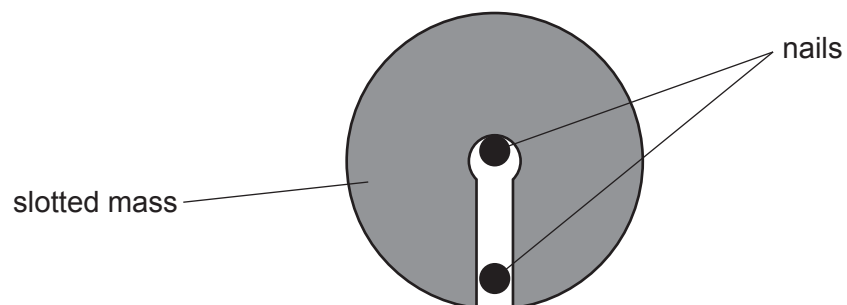

Fig. 1.2

- Load **all** of the masses onto the nails in the positions shown in Fig. 1.3.

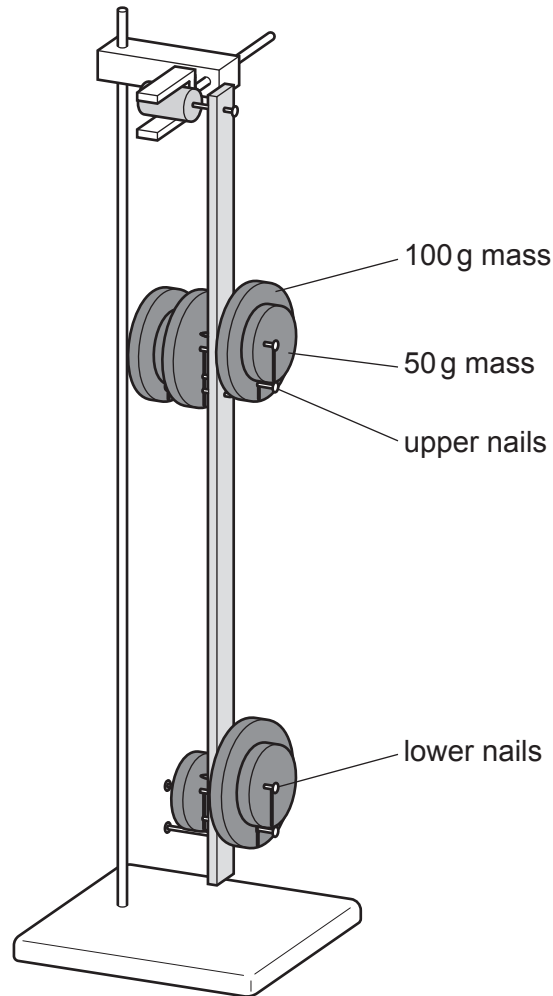

Fig. 1.3

- Record the total mass M_L on the four **lower** nails.

$$M_L = \dots\dots\dots [1]$$

- (ii)
- Push the bottom of the rod through a short distance and release it so that it oscillates.
 - Take measurements to determine the period T of these oscillations.

$$T = \dots\dots\dots [2]$$

4

- (b) Rearrange the slotted masses between the upper and lower nails.
Record M_L and determine T . Repeat until you have six sets of values.

Use **all** of the slotted masses each time so that the mass of the pendulum is constant.

Record your results in a table. Include values of $\sqrt{M_L}$ to three significant figures in your table.

- [9]
- (c) (i) Plot a graph of T on the y -axis against $\sqrt{M_L}$ on the x -axis. [3]
- (ii) Draw the straight line of best fit. [1]
- (iii) Determine the gradient and y -intercept of this line.

gradient =

y -intercept =

[2]



6

(d) It is suggested that the quantities T and M_L are related by the equation

$$T = a\sqrt{M_L} + b$$

where a and b are constants.

Using your answers in (c)(iii), determine the values of a and b .
Give appropriate units.

$a =$

$b =$

[2]

[Total: 20]

You may not need to use all of the materials provided.

2 In this experiment, you will investigate the optical properties of a transparent block.

(a) You are provided with a semicircular transparent block.

Take measurements to determine the radius of curvature R of the curved surface, as shown in Fig. 2.1.

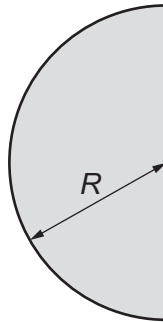

Fig. 2.1

$R =$ [1]

(b) (i) You are provided with a piece of paper labelled P with four parallel lines drawn on it.

- A is the distance between the two central lines and B is the distance between the two outer lines.

Measure and record A and B .

$A =$

$B =$

- Calculate E using

$$E = \frac{B}{A}$$

$E =$ [1]

- (ii) • Arrange the apparatus as shown in Fig. 2.2.

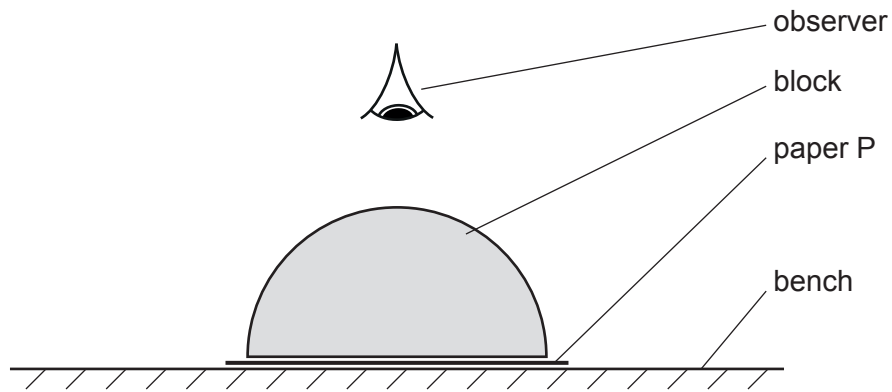

Fig. 2.2

- Look down through the block and close one eye. The appearance of the lines should be similar to Fig. 2.3.

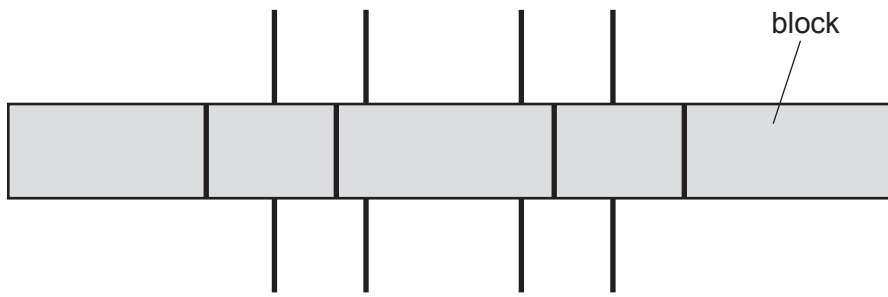

Fig. 2.3

- Gradually raise the block until the two central lines seen through the block are aligned with the two outer lines seen outside the block, as shown in Fig. 2.4. You may have to move your head sideways to see this alignment.

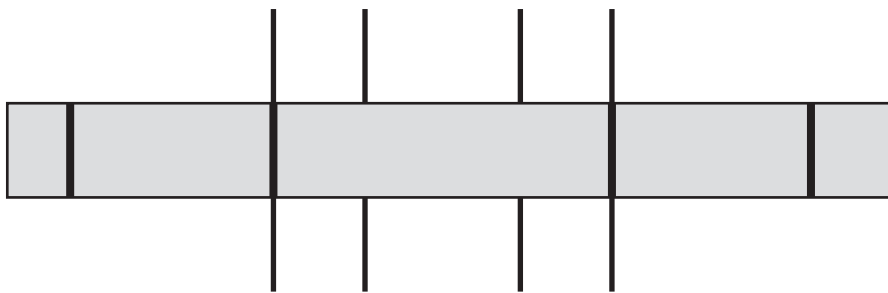

Fig. 2.4

9

- With the block in this position, measure and record the height d_1 of the block above the paper, as shown in Fig. 2.5.

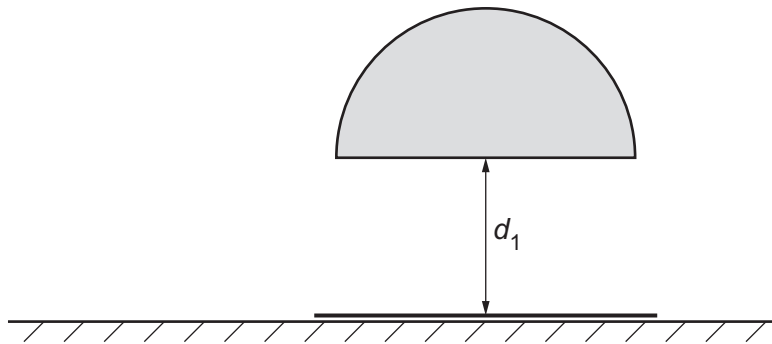

Fig. 2.5

$d_1 = \dots\dots\dots$ cm [2]

- (iii) Estimate the percentage uncertainty in your value of d_1 .
Show your working.

percentage uncertainty = $\dots\dots\dots$ % [1]

- (iv)
- Turn the block over and lower the curved face onto the paper.
 - Look down through the block and close one eye.
 - Gradually raise the block until the two central lines seen through the block are aligned with the two outer lines seen outside the block.
 - Measure and record the height d_2 of the block above the paper, as shown in Fig. 2.6.

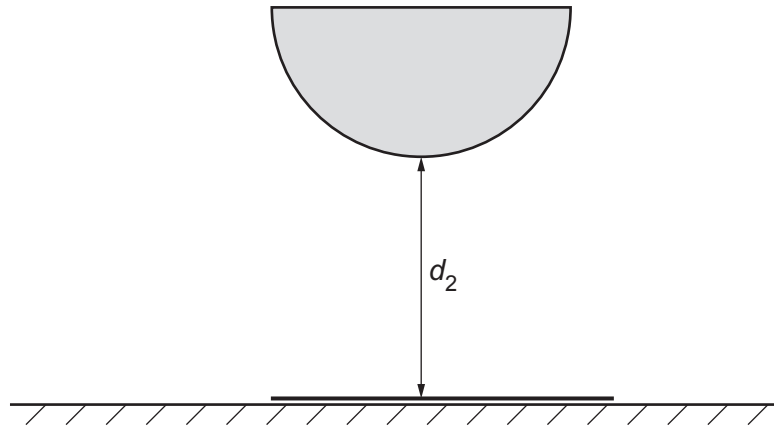

Fig. 2.6

$d_2 = \dots\dots\dots$ cm [1]

(c) Repeat (b)(i), (b)(ii) and (b)(iv) but this time using the piece of paper labelled Q.

$A =$

$B =$

$E =$

$d_1 =$ cm

$d_2 =$ cm
[3]

- (d) It is suggested that the relationship between R , d_1 and d_2 is

$$2k = R + d_1 - d_2$$

where k is a constant.

Using your data, calculate two values of k .

first value of k =

second value of k =

[1]

- (e) It is suggested that the percentage uncertainty in the values of k is 5%.

Using this uncertainty, explain whether your results support the relationship in (d).

.....

 [1]

- (f) A property of the block called the focal length f is given by

$$f = \frac{E(d_2 + k)}{(E - 1)}$$

Using your results from (c) and your second value of k , calculate the value of f .

f = [1]

(g) (i) Describe **four** sources of uncertainty or limitations of the procedure for this experiment.

For any uncertainties in measurement that you describe, you should state the quantity being measured and a reason for the uncertainty.

1

.....

2

.....

3

.....

4

.....

[4]

(ii) Describe **four** improvements that could be made to this experiment. You may suggest the use of other apparatus or different procedures.

1

.....

2

.....

3

.....

4

.....

[4]

[Total: 20]

BLANK PAGE

Permission to reproduce items where third-party owned material protected by copyright is included has been sought and cleared where possible. Every reasonable effort has been made by the publisher (UCLES) to trace copyright holders, but if any items requiring clearance have unwittingly been included, the publisher will be pleased to make amends at the earliest possible opportunity.

To avoid the issue of disclosure of answer-related information to candidates, all copyright acknowledgements are reproduced online in the Cambridge Assessment International Education Copyright Acknowledgements Booklet. This is produced for each series of examinations and is freely available to download at www.cambridgeinternational.org after the live examination series.

Cambridge Assessment International Education is part of Cambridge Assessment. Cambridge Assessment is the brand name of the University of Cambridge Local Examinations Syndicate (UCLES), which is a department of the University of Cambridge.