

Section A

Answer all questions in this section.

A high-street insurance company is called 'CLARK INSURANCE'. The insurance company has a logo and signboard that is made up from geometrical shapes depicting the letters **C**, **K** and **I** of the name as shown in the drawing below.

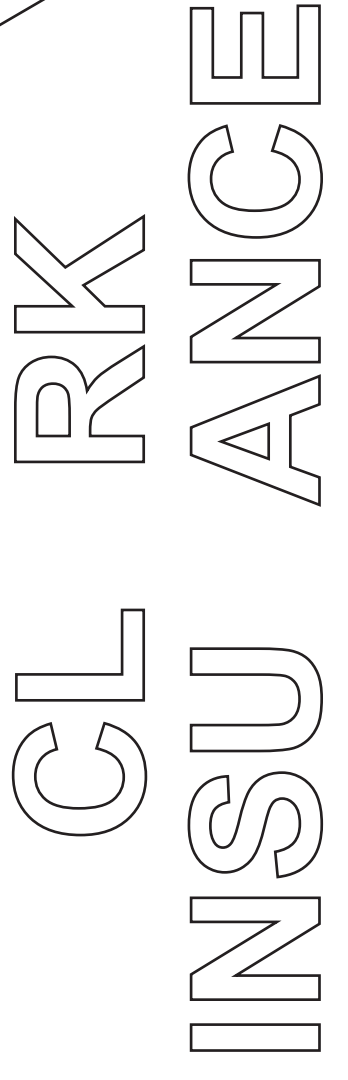
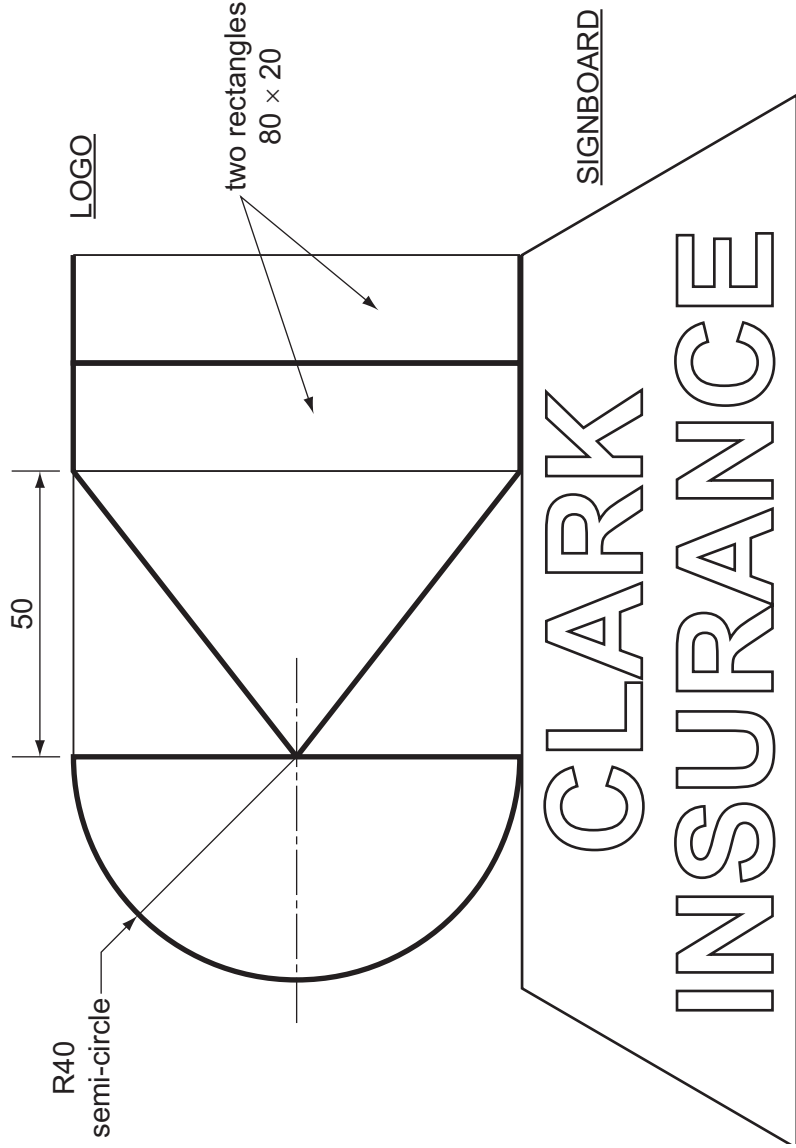

- 1 Complete the full-size view of the logo started on the right by drawing:
 - (a) the semi-circle that represents the letter **C**; [2]
 - (b) the triangle that completes the letter **K**; [2]
 - (c) the two rectangles required to complete the letter **I**; [4]
 - (d) thick lines to enhance the letters **C**, **K** and **I**. [1]

- A2 (a) Complete the signboard for CLARK INSURANCE by adding the **two** missing letters. All the letters must be to the same height and style as those given. [4]
- (b) Complete the quadrilateral border to the signboard so that the shape is symmetrical. [2]

For Examiner's use	

0445/23 May/June 2013 1 hour
© UCLES 2013

Centre Number

Candidate's Number

Other Names

[Turn over]

A3 A charity collection box for customer use is shown in orthographic views below.

Lines are printed on the box to highlight the letters **K** and **I**.

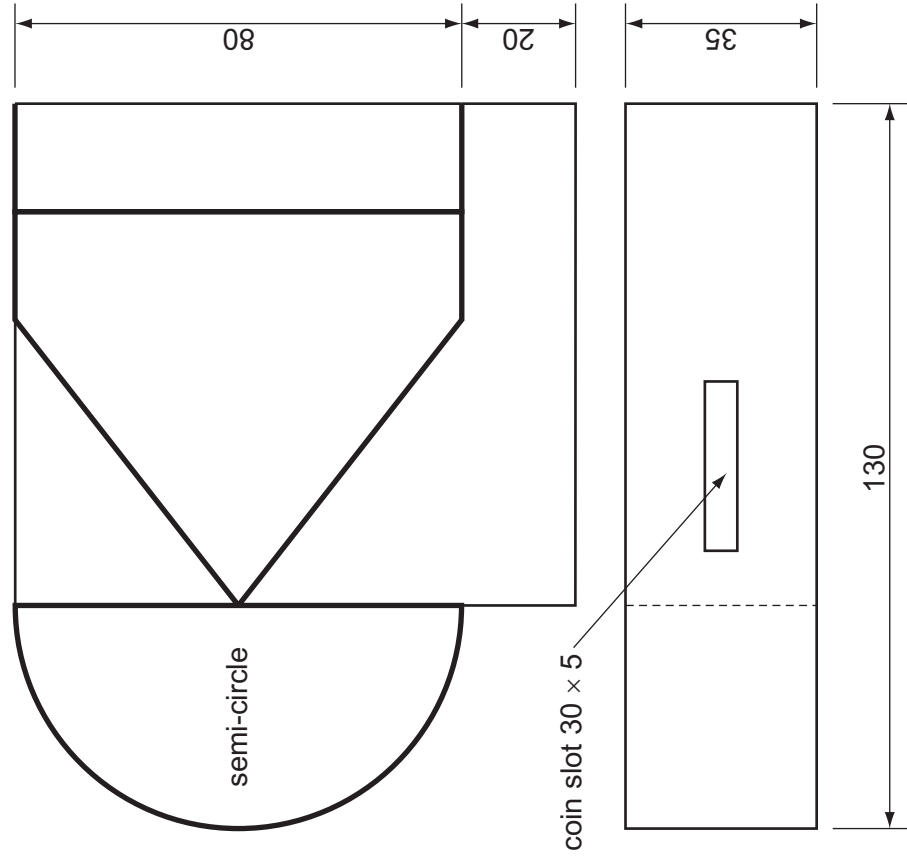

- (a) In the space to the right, draw a full-size isometric view of the collection box. [7]
- (b) Add to your isometric drawing the printed-on lines that highlight the letters **K** and **I**. [2]
- (c) Draw the 30 x 5 coin slot on the correct face of your isometric collection box. [1]

Section B
Answer either question **B4** or **B5**.

B4 The CLARK INSURANCE office uses a card folder for customers' documents. The folder is made from a one-piece development of thin card. The card is folded to provide two document pockets as shown in the drawing below.

The folder uses arrow-tabs and slots to form pocket 1. Pocket 2 is formed by the use of a glue tab.

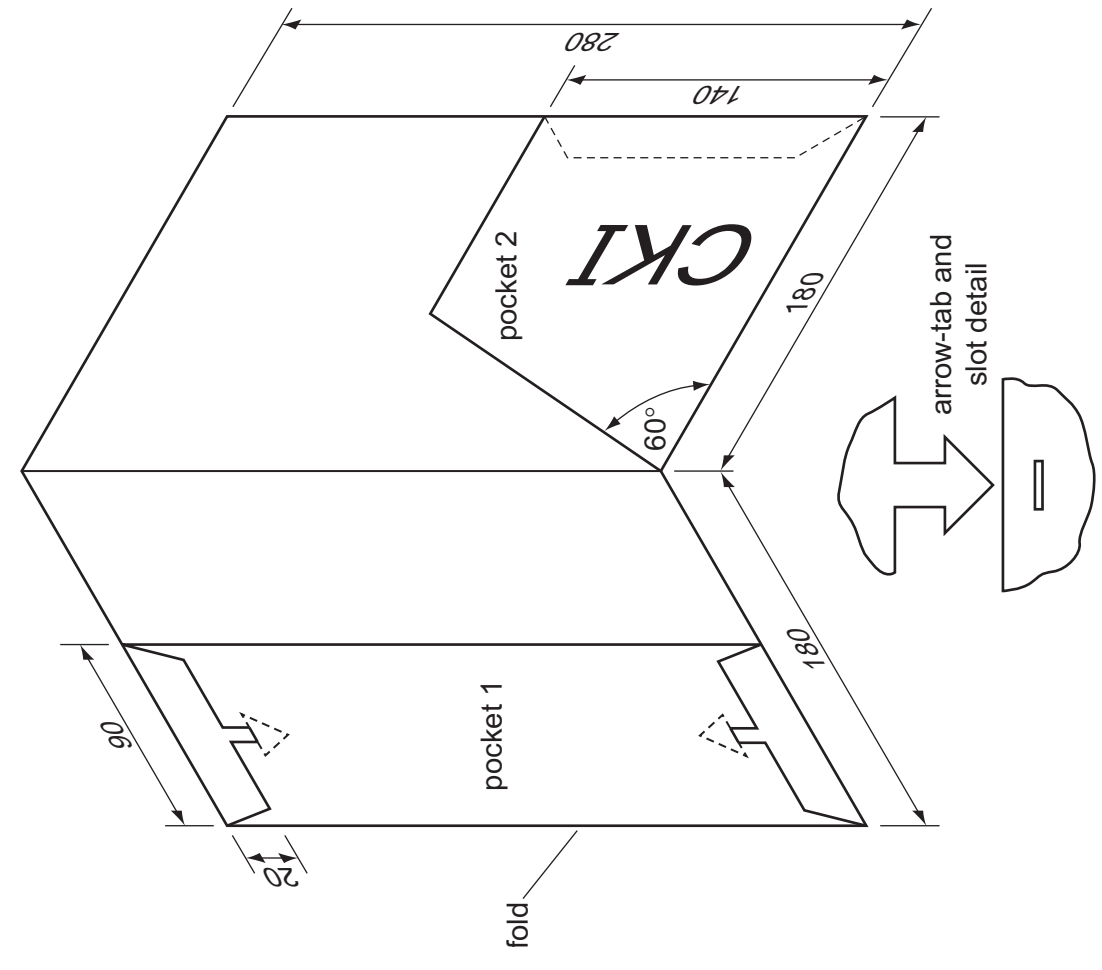

- (a) In the space to the right, draw to a scale of 1:2 a one-piece development (net) of the folder including the glue tab for pocket 2. [13]
- (b) Add to your development two arrow-tabs and slots for pocket 1. [8]
- (c) Write the letters **C K I** in the correct orientation on the correct face of your development. [4]

0445/23 May/June 2013 **1 hour**
© UCLES 2013

Centre Number

Candidate's Number

Candidate's Surname

Other Names

[Turn over]

B5 The CLARK INSURANCE company sells different types of insurance. The sales on one particular day are listed below.

Type of insurance	Sales
Car insurance	\$6000
Buildings insurance	\$3000
House contents insurance	\$4500
Personal insurance	\$1500
Travel insurance	\$2250
Pet insurance	\$ 750

(a) In the space below, draw and label a two-dimensional pie chart to show the sales of each type of insurance on this day. [7]

b) The table shows the number of customers who purchased insurance during one particular week in 2012.

Day of the week	Monday	Tuesday	Wednesday	Thursday	Friday
domestic customers	550	650	800	850	950
corporate customers	450	600	650	500	850
TOTAL	1000	1250	1450	1350	1800

(i) In the space below, draw a suitable two-dimensional bar chart to show the TOTAL number of customers each day over the five days of this week. [3]

(ii) In the space below, draw a three-dimensional bar chart to show the numbers of each type of customer over the five days of this week. [15]