



**Cambridge International Examinations**  
Cambridge International General Certificate of Secondary Education

---

**DESIGN AND TECHNOLOGY**

**0445/43**

Paper 4 Systems and Control

**May/June 2016**

MARK SCHEME

Maximum Mark: 50

---

**Published**

This mark scheme is published as an aid to teachers and candidates, to indicate the requirements of the examination. It shows the basis on which Examiners were instructed to award marks. It does not indicate the details of the discussions that took place at an Examiners' meeting before marking began, which would have considered the acceptability of alternative answers.

Mark schemes should be read in conjunction with the question paper and the Principal Examiner Report for Teachers.

Cambridge will not enter into discussions about these mark schemes.

Cambridge is publishing the mark schemes for the May/June 2016 series for most Cambridge IGCSE<sup>®</sup>, Cambridge International A and AS Level components and some Cambridge O Level components.

Page 2	Mark Scheme	Syllabus	Paper
	Cambridge IGCSE – May/June 2016	0445	43

## Section A

- 1 (a) A moment is **force**  $\times$  **distance**, turning effect or force which tries to cause turning, 1 mark [1]
- (b) (i) **300 N**, 1 mark [1]
- (ii) The beam will move to a horizontal position, 1 mark.  
It will remain in equilibrium in that position, 1 mark.  
Allow marks for understanding shown. [2]
- 2 Evidence of cross braces / triangulation to prevent front to back movement, 1 mark.  
Cross braces / triangulation to prevent side to side movement, 1 mark.  
Clear annotation, 1 mark. No width shown on braces, max. 1 mark. [3]
- 3 A strain gauge could be glued across the crack and the strain gauge resistance measured either at regular intervals or constantly to detect a widening of the gap.  
A glass plate could be glued to the surface of the beam either side of the crack; if the glass shatters the crack has got wider.  
The width of the crack could be **accurately** measured e.g. using an electronic calliper to measure the width. Clear description of one of these methods, 2 marks.  
Mention of two different methods, 2 marks. Mention of one method with no detail, 1 mark. No mark for using ruler. [2]
- 4 (a) Methods of transferring drive from motor could be:
- Belt and pulley, 'pulleys' without 'belt' = no mark
  - Chain drive
  - Direct gears
  - Friction drive
- 3  $\times$  1 marks [3]
- (b) Possible effects could be:
- Loss of power through friction / sound / heat
  - Rotation of motor speed to driven speed can be altered  
Only 1 mark for both increase and decrease of speed
  - Change in torque
  - Change in direction of motion
  - Slipping can occur if a friction drive or belt and pulley are used
  - Wear in bearings
- 2  $\times$  1 marks [2]
- 5 (a) 1 mark for one correct, 2 marks for 2 or 3 correct.

Effort	<b>R</b>
Load	<b>T</b>
Fulcrum	<b>S</b>

[2]

Page 3	Mark Scheme	Syllabus	Paper
	Cambridge IGCSE – May/June 2016	0445	43

(b) First order lever / 1st class lever, 1 mark. [1]

6 (a) LED differences can include:

- Colour
- Size
- Shape
- Brightness / intensity
- Mounting method through hole / SMD
- Angle of output
- Forward voltage
- Frequency of light

3 × 1 marks

[3]

(b) Electrolytic capacitor legs can be identified by a series of ‘-’ or ‘+’ symbols on the body covering and the **cathode is shorter**, no crimp around body of axial version.

2 × 1 marks

[2]

7 1 mark for each correct

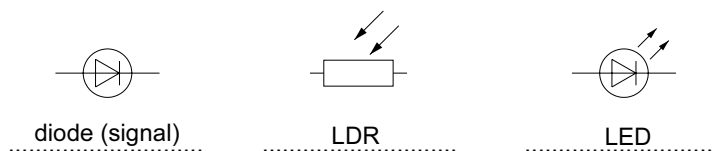

[3]

[Total: 25]

Page 4	Mark Scheme	Syllabus	Paper
	Cambridge IGCSE – May/June 2016	0445	43

## Section B

8 (a) (i) 1 mark for each correct connection [3]

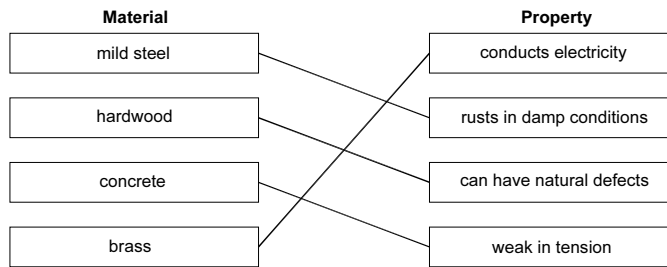

(ii) Methods of treating steel will include:

- Painting
- Galvanising
- Powder coating
- Electroplating

2 × 1 marks for suitable methods.

[2]

(iii) Bolt shown joining parts together, 1 mark.

Indication of forces causing shear e.g. arrows, 1 mark.

Clear indication of the effect of a shear force on the bolt, 1 mark.

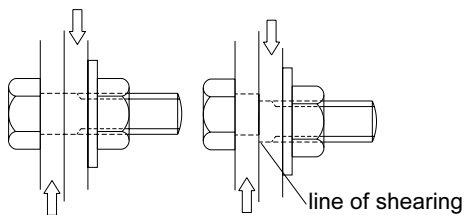

[3]

(b) (i) Reasons could include:

- Strength to weight ratio when compared to solid beam
- Resistance to torsion
- Resistance to bending
- Standard component
- Accept lower cost, if qualified

2 × 1 marks for suitable reasons.

[2]

(ii) Reasons for using concrete will include:

- Strong in compression, which is the main force that will be acting on the foundation
- Can easily be reinforced with steel bar to resist tension
- Can flow into difficult / intricate shapes
- Can be pumped into a foundation
- Relatively low cost as ballast is readily available in most area
- Will not degrade underground / long lasting

Detailed explanation including two points, 3 marks.

Detailed explanation of any one point, 2 marks.

List of point with little explanation, 1 mark.

[3]

Page 5	Mark Scheme	Syllabus	Paper
	Cambridge IGCSE – May/June 2016	0445	43

- (c) (i) A strut will resist **compressive** force, 1 mark.  
A tie will resist **tensile** force, 1 mark. [2]

- (ii) 1 mark for each correct.

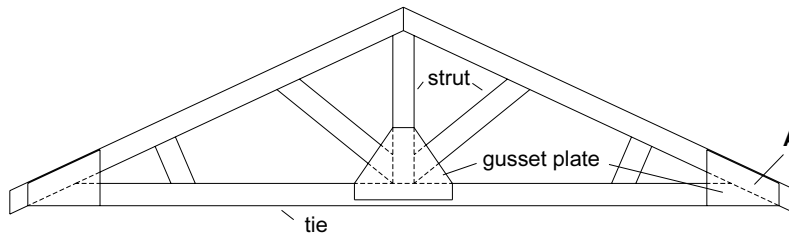

[3]

- (iii) Use of a suitable method of joining rafter to tie, 1 mark.  
Gusset plate attached securely, 1 mark.  
Clear annotation to sketches, 1 mark.

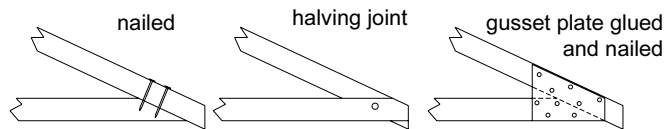

[3]

- (iv) Problems with using wood will include:

- Natural defects, e.g. knots, splits
- Insect damage
- Wet / dry rot
- Movement of the wood, warping / bending / twisting

2 × 1 marks

[2]

- (v) Static load is a non-moving load applied to a structure; a dynamic load will change quickly. Static load will include the loading caused by the parts of the structure. Some items can be both static and dynamic e.g. vehicles at rest on a bridge are a static load until they start to move, when they become dynamic.

Description showing understanding of both types of load, 2 marks.

Understanding of one type, 1 mark.

[2]

[Total: 25]

- 9 (a) (i) **Worm** gear or worm wheel, 1 mark [1]

- (ii) Reasons for using a worm gear will include:

- High reduction ratio. Allow 'reduces the speed'
- Does not take up much room
- Can only operate in one direction (no slipping)
- Less frictional loss than a spur gear system
- Increased torque
- Turns drive through 90°

Allow any other valid reason, 2 × 1 marks.

[2]

- (iii) **45:1**, 1 mark for values, 1 mark for correct way around. [2]

<b>Page 6</b>	<b>Mark Scheme</b>	<b>Syllabus</b>	<b>Paper</b>
	<b>Cambridge IGCSE – May/June 2016</b>	<b>0445</b>	<b>43</b>

(b) (i) The ring is magnetic, 1 mark and it will close the reed switch when directly underneath it, 1 mark. [2]

(ii) 1 mark for each column correct. Accept **on / off, 1 / 0**.

	instroked	moving / central	outstroked
reed switch 1	<b>closed</b>	<b>open</b>	<b>open</b>
reed switch 2	<b>open</b>	<b>open</b>	<b>closed</b>

[3]

(iii) The reed switches give electronic feedback on the position of the piston, 1 mark. Reciprocating movement is converted into a (digital) electronic signal, 1 mark. [2]

(c) (i) Safety precautions for compressed air will include:

- Pressure regulation
- Safety valve in the receiver tank
- Checks for corrosion in the receiver tank

Allow other valid precautions, 1 mark.

[1]

Safety precautions for mains electricity will include:

- Use of fuses / residual current device
- Visual inspection of wiring
- Isolation from damp / wet / explosive conditions

Allow other valid precautions, 1 mark.

[1]

(ii) Benefits of wind power include:

- It is a renewable resource
- No pollution

Allow other valid responses, 1 mark.

[1]

Drawbacks include:

- Weather conditions are not always right for optimum performance
- Speed of device will need governing in high winds

Allow other valid responses, 1 mark.

[1]

Page 7	Mark Scheme	Syllabus	Paper
	Cambridge IGCSE – May/June 2016	0445	43

(d) (i) 1 mark for each item correctly identified.

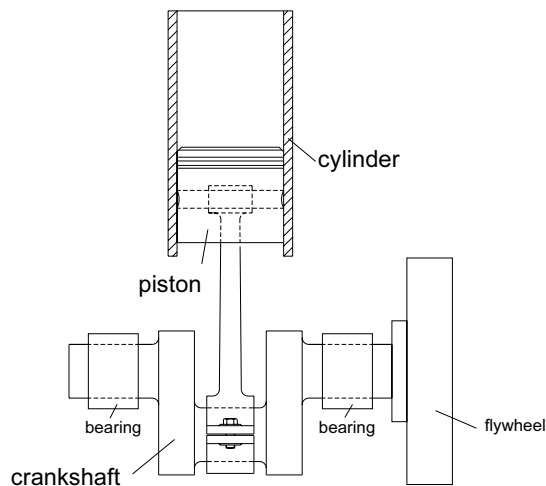

[3]

(ii) **Reciprocating** motion is converted to **rotary** motion.

[2]

(iii) Two lubrication points, 1 mark each.

Could be bearings, small end, big end, cylinder wall.  
Accept marking on either view of engine parts.

[2]

(iv) Reasons for using a roller bearing include:

Can take a high radial load, better than a ball bearing  
Will operate at high speed if well lubricated  
Can be sealed for life  
Longer lasting than a plain bearing

2 × 1 marks

[2]

[Total: 25]

10 (a) (i) Description should include a graph to show that the astable is a regular square wave, 1 mark and has constant amplitude, 1 mark. [2]

(ii) A push to make switch will make contact when pressed, 1 mark, break contact when released, 1 mark. [2]

(iii) The multimeter dial should be set to  $\Omega$  or continuity setting. [1]

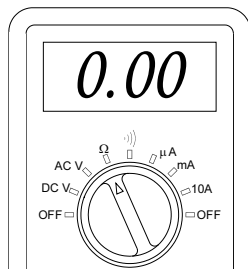

(iv) The reading should be less than 1  $\Omega$ , 1 mark, allow buzzer may sound, 1 mark. [1]

Page 8	Mark Scheme	Syllabus	Paper
	Cambridge IGCSE – May/June 2016	0445	43

(v) AND gate, 1 mark. Output column correct, 1 mark.

R	S	Q
0	0	0
0	1	0
1	0	0
1	1	1

[2]

(vi) Resistor to 0V, 1 mark. Switch to +9V, 1 mark, Switch / resistor junction to S, 1 mark.

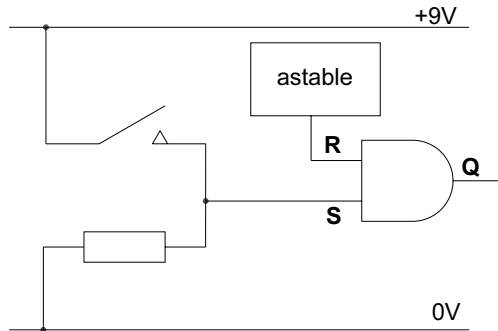

[3]

(vii) Explanation should refer to the AND gate only passing on a signal when both inputs are high, 1 mark. When the switch is at 0V there can be no signal passing through the gate, 1 mark.

[2]

(b) (i)  $R1 + 2R2 = 21\,000$ , 1 mark.  $21\,000 \times 0.000001 = 0.021$ , 1 mark.  
 $1.44 / 0.021 = 68.57\text{ Hz}$ , 1 mark. 3 marks for correct answer with no working.

[3]

(ii) 1 mark for each connection correct,  $3 \times 1$  marks.

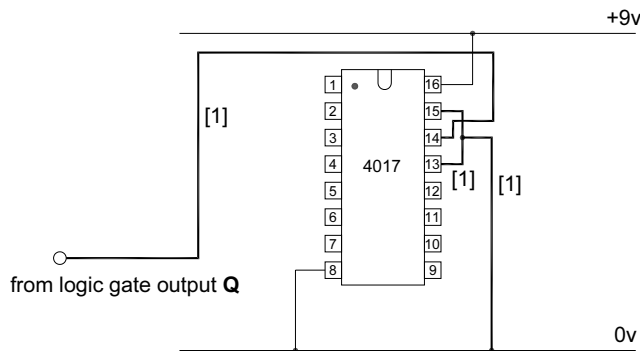

[3]



Page 9	Mark Scheme	Syllabus	Paper
	Cambridge IGCSE – May/June 2016	0445	43

- (c) Base and emitter connections correct, 1 mark.  
 Collector to resistor or collector to LED, 1 mark.  
 LED connected to +9V and resistor, 1 mark.

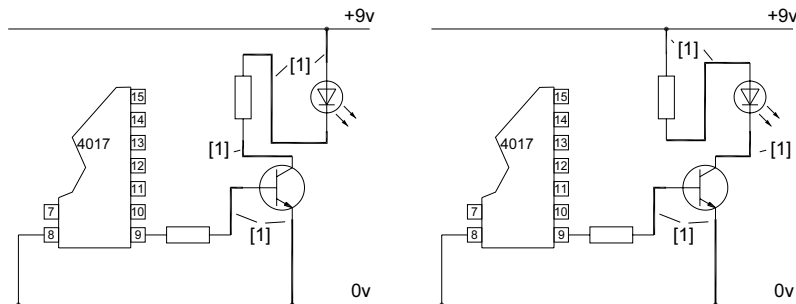

[3]

- (d) The following stages will be needed:  
 Cut the LED legs off close to the board, 1 mark.  
 Heat up joint with soldering iron, 1 mark  
 Use desoldering tool (solder sucker) or braid to remove the excess solder, 1 mark.  
 Support circuit board above work surface so that the LED can be pushed out with soldering iron or pull with long nose pliers, 1 mark.  
 Any three valid points, 3 × 1 marks.

[3]

[Total: 25]