



**Cambridge Assessment International Education**  
Cambridge International General Certificate of Secondary Education

---

**DESIGN AND TECHNOLOGY**

**0445/22**

Paper 2 Graphic Products

**May/June 2019**

MARK SCHEME

Maximum Mark: 50

---

**Published**

This mark scheme is published as an aid to teachers and candidates, to indicate the requirements of the examination. It shows the basis on which Examiners were instructed to award marks. It does not indicate the details of the discussions that took place at an Examiners' meeting before marking began, which would have considered the acceptability of alternative answers.

Mark schemes should be read in conjunction with the question paper and the Principal Examiner Report for Teachers.

Cambridge International will not enter into discussions about these mark schemes.

Cambridge International is publishing the mark schemes for the May/June 2019 series for most Cambridge IGCSE™, Cambridge International A and AS Level and Cambridge Pre-U components, and some Cambridge O Level components.

---

This document consists of **5** printed pages.

**Generic Marking Principles**

These general marking principles must be applied by all examiners when marking candidate answers. They should be applied alongside the specific content of the mark scheme or generic level descriptors for a question. Each question paper and mark scheme will also comply with these marking principles.

**GENERIC MARKING PRINCIPLE 1:**

Marks must be awarded in line with:

- the specific content of the mark scheme or the generic level descriptors for the question
- the specific skills defined in the mark scheme or in the generic level descriptors for the question
- the standard of response required by a candidate as exemplified by the standardisation scripts.

**GENERIC MARKING PRINCIPLE 2:**

Marks awarded are always **whole marks** (not half marks, or other fractions).

**GENERIC MARKING PRINCIPLE 3:**

Marks must be awarded **positively**:

- marks are awarded for correct/valid answers, as defined in the mark scheme. However, credit is given for valid answers which go beyond the scope of the syllabus and mark scheme, referring to your Team Leader as appropriate
- marks are awarded when candidates clearly demonstrate what they know and can do
- marks are not deducted for errors
- marks are not deducted for omissions
- answers should only be judged on the quality of spelling, punctuation and grammar when these features are specifically assessed by the question as indicated by the mark scheme. The meaning, however, should be unambiguous.

**GENERIC MARKING PRINCIPLE 4:**

Rules must be applied consistently e.g. in situations where candidates have not followed instructions or in the application of generic level descriptors.

**GENERIC MARKING PRINCIPLE 5:**

Marks should be awarded using the full range of marks defined in the mark scheme for the question (however; the use of the full mark range may be limited according to the quality of the candidate responses seen).

**GENERIC MARKING PRINCIPLE 6:**

Marks awarded are based solely on the requirements as defined in the mark scheme. Marks should not be awarded with grade thresholds or grade descriptors in mind.

## Section A

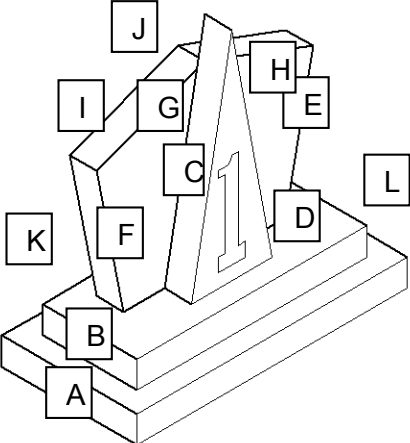
Question	Answer	Marks
A1(a)	Left side lower arc R160 (1) Two top arcs R60 (1)	2
A1(b)	<u>Half hexagon:</u> Semi-circle $\varnothing 100$ (1) On correct centre (1) Two equal sides drawn to bottom of semi-circle (1)  <u>Inner triangle and hexagon shapes:</u> Circle $\varnothing 80$ (Hex 80 A/C) (1) Regular hexagon drawn (1) Equilateral triangle shape drawn (1)	6
A1(c)	Accuracy and proportion of: Spacing (1) (or one letter only) Size (height, width and thickness) of letters (1)	2
A2	 <p>Left side of lower base – A (1) Left side of upper base – B (1) Thickness added to centre front piece – C (1)  Front bottom edge of back pentagon – D (1) Front right sloping side of back pentagon – E (1) Left sloping side of back pentagon – F (1) Front left top edge of pentagon (to cand solution) – G (1) Front right top edge of pentagon (to cand solution) – H (1)  Thickness added to pentagon – I (1) Three top corner lines of pentagon at <math>30^\circ</math> or P// – J (1) Two back top edges of bases – K (1) Two right back top edges of bases p// to L/H solution – L (1)</p>	12
A3	Drawn on CAD or computer using a suitable program (1) Suitable material for stencil such as card / thin plastic – selected (1) Shape on No.'1' then cut out using a piece of CAM equipment such as laser cutter, vinyl cutter, STIKA, CAMM1 etc. (1)	3

## Section B

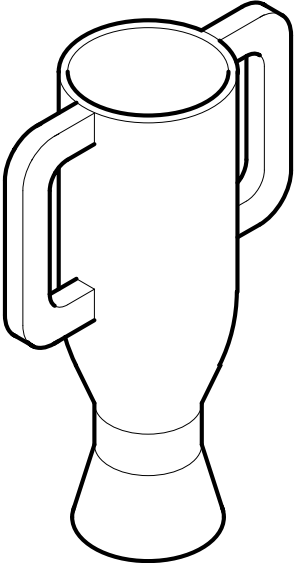
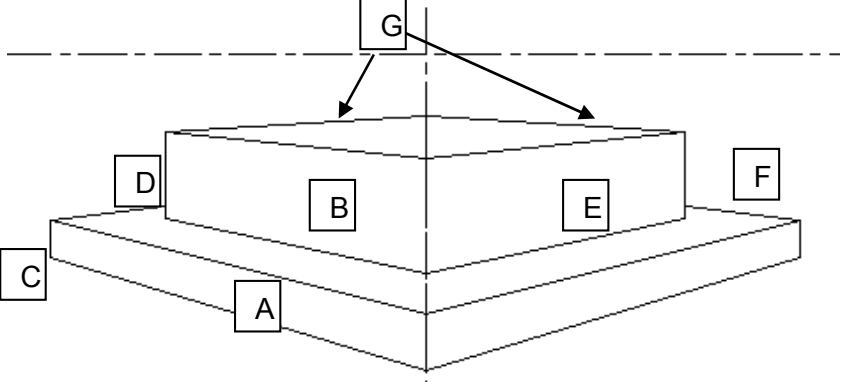
Question	Answer	Marks
B4(a)	<p>Three steps each 30 mm wide (1)            Middle step 30 mm high (1)            Five top lines back from corners of front face 40 mm long (1)            Back edge of podium completed (any size) (1)</p> <p>Centre backboard drawn 60 mm high from top face of step (1)            Second and Third place backboard drawn 60 mm high from top face of step (1)            Five corner lines added to show 5 mm thickness (1)            Back edge of backboard completed to candidate solution(1)</p>	8
B4(b)	 <p><u>Thick lines:</u>            Bottom curved line to outside of base (1)            Right hand side of cup from base to top lip (1)            Left hand side of cup from base to top lip including in between handle (1)</p> <p>Top outer lip of cup (1)            Inner bottom lip of cup (1)</p> <p>Rear outline of left handle (1)            Front inner edge of left handle (1)</p> <p>Rear outline of right handle (1)            Back inner edge of right handle (1)</p>	9
B4(c)	 <p>Two left side front edges of bottom piece drawn to VP1 (1) – A            Two left side front edges of top piece drawn to VP1 (1) – B            Vertical back edge of bottom piece (1) – C            Vertical back edge of top piece (1) – D</p> <p>Right side front edges of top piece drawn to VP2 (1) – E            Two back edges to V.P (1) – F            Two top back edges of top piece drawn to VP1 &amp; 2 (1) – G            Overall drawing in proportion and lined in [1]</p>	8

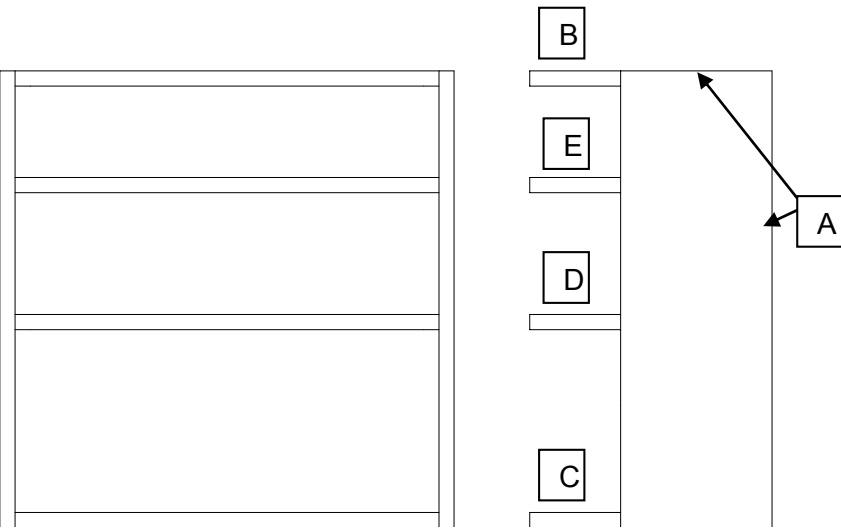
Question	Answer	Marks
B5(a)	 <p>Side view: Outline of side panel 73 25 (1) – A Top shelf 15 × 2 in correct position (1) – B Bottom shelf 15 × 2 in correct position (1) – C Middle shelf D, 2 mm thick and in correct positions (1) Middle shelf E, 2 mm thick and in correct positions (1)</p> <p>Front view: Outline projected from side view or plan (1) 2mm thickness to top, bottom and sides (1) Two middle shelves level with side view (1) Top and bottom shown internally to sides (1) Two middle shelves shown internally to sides (1)</p>	10
B5(b)	Some shading added (1) Shading shows that the doors are curved (1) Shading makes doors look like glass (1)	3
B5(c)(i)	Inner handle 54 × 36 completed (1) Outer handle size 90 × 30 completed (1) Sectional Hatching to 'body' of handle (1)	3
B5(c)(ii)	Felt washer drawn in correct position to left side of glass (1) Felt washer drawn 3 mm thick (1) Felt washer drawn 54 mm OD (1) Inner hole lines shown in line with existing (1)	4
B5(c)(iii)	Metal washer drawn 36 mm OD (1) Metal washer drawn 3 mm thick (1) Inner holes shown in line with existing (1)	5
	Nut drawn 30 mm AF (1) Nut drawn 15 mm thick (1)	