



## Cambridge IGCSE™

CANDIDATE  
NAME
CENTRE  
NUMBER

--	--	--	--	--

CANDIDATE  
NUMBER

--	--	--	--

**DESIGN & TECHNOLOGY****0445/33**

Paper 3 Resistant Materials

**May/June 2021****1 hour**

You must answer on the question paper.

No additional materials are needed.

**INSTRUCTIONS**

- Section A: answer **all** questions.
- Section B: answer **one** question.
- Use a black or dark blue pen. You may use an HB pencil for any diagrams or graphs.
- Write your name, centre number and candidate number in the boxes at the top of the page.
- Answer in the space provided.
- Do **not** use an erasable pen or correction fluid.
- Do **not** write on any bar codes.
- You may use a calculator.

**INFORMATION**

- The total mark for this paper is 50.
- The number of marks for each question or part question is shown in brackets [ ].
- All dimensions are in millimetres.

This document has **20** pages. Any blank pages are indicated.

**Section A**

Answer **all** questions in this section.

- 1 Draw on Fig. 1.1 to show the construction of blockboard.

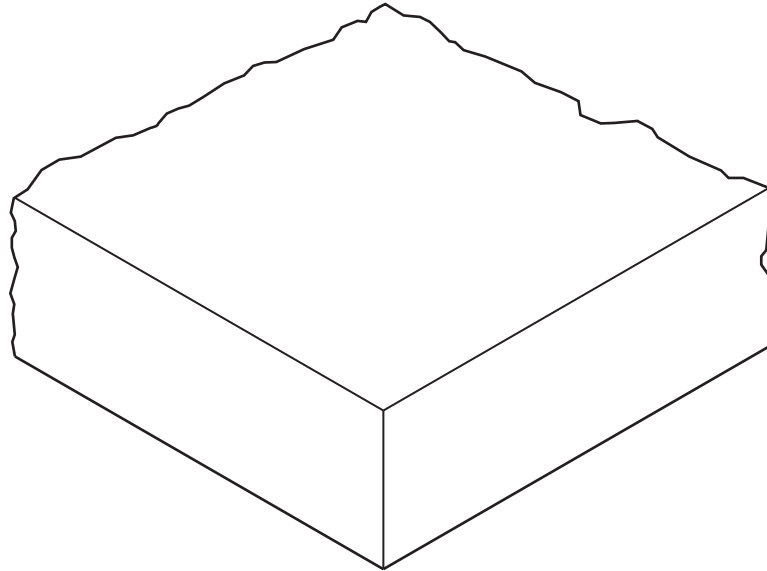

**Fig. 1.1**

[4]

- 2 Complete the statement below by adding the correct term from the list.

**manufactured      composite      pure      hardened**

Carbon fibre reinforced plastic (CFRP) is an example of a ..... material. [1]

- 3 Fig. 3.1 shows a solid wood board that has warped.

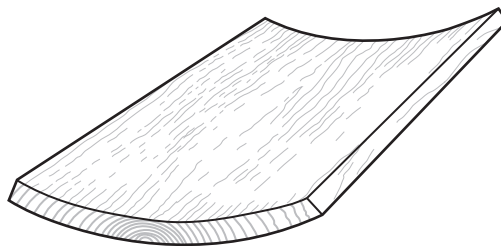

**Fig. 3.1**

Give **two** reasons why the solid wood board has warped.

1 .....

2 .....

[2]

4 Fig. 4.1 shows a digital caliper.

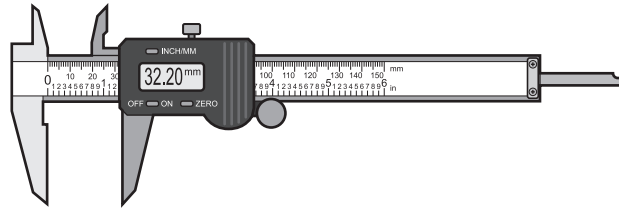

Fig. 4.1

Add sketches and notes to Fig. 4.1 to show **two** specific uses for the digital caliper. [2]

5 Fig. 5.1 shows a surface plate and scribing block.

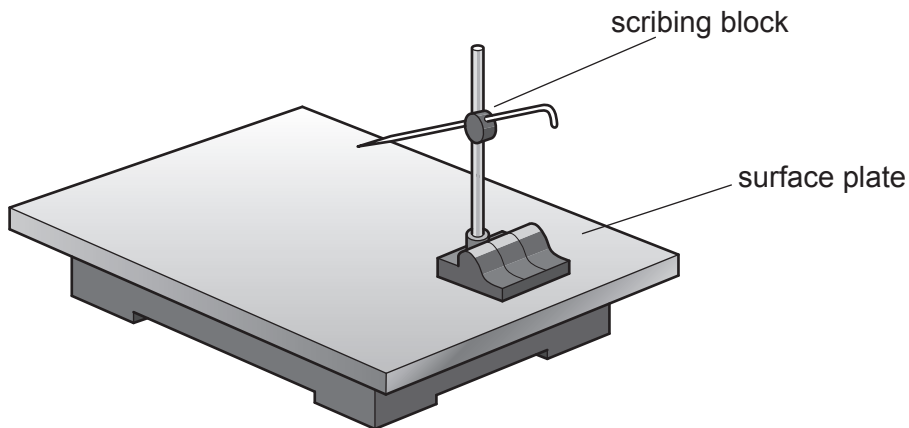

Fig. 5.1

Give **two** reasons why the surface plate and scribing block provide great accuracy when marking out metal.

1 .....

2 .....

[2]

6 (a) Complete the statement below by adding the correct term from the list.

- polystyrene      polypropylene      polythene      polyester**

Glass-reinforced plastic (GRP) is produced by laminating layers of glass-fibre mat with ..... resin. [1]

(b) Some car bodies are made from glass-reinforced plastic (GRP).

Give **two** advantages of using GRP rather than steel for car bodies.

- 1 .....
  - 2 .....
- [2]

7 Fig. 7.1 shows an incomplete drawing of a hasp and staple fitting.

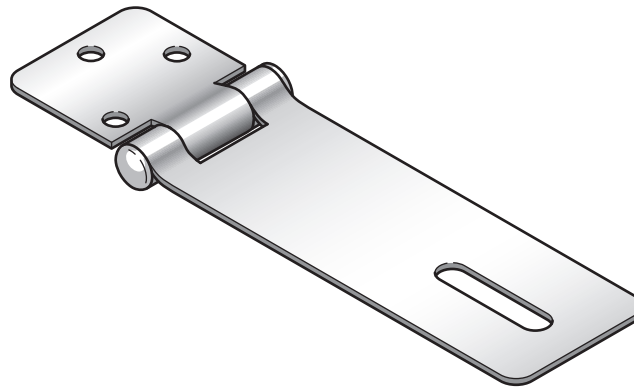

**Fig. 7.1**

Add sketches and notes to Fig. 7.1 to complete the drawing of the hasp and staple fitting. [2]

- 8 Fig. 8.1 shows a chair leg made from a length of hardwood 100 mm wide × 20 mm thick. The chair leg has been formed by steam bending.

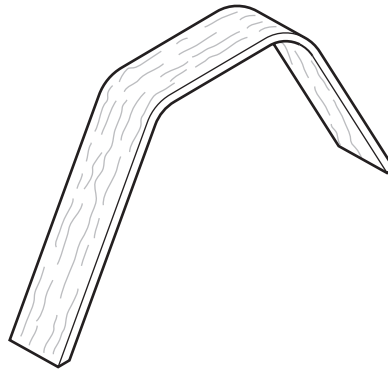

Fig. 8.1

Give **three** main stages when steam bending the length of hardwood to make the chair leg.

- 1 .....
- 2 .....
- 3 .....

[3]

- 9 Fig. 9.1 shows a workshop operation where there is a danger of damaging the material.

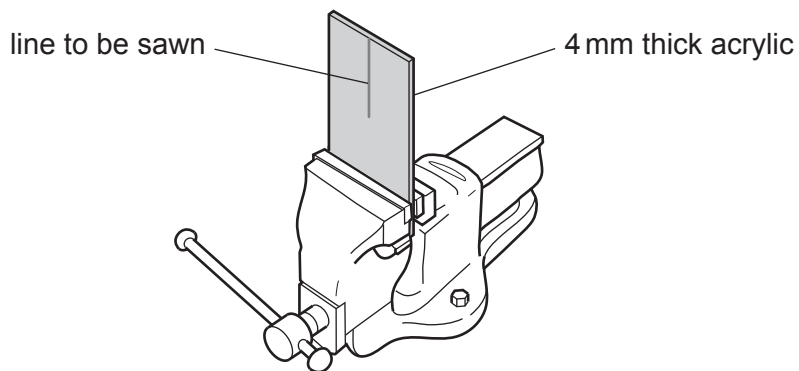

Fig. 9.1

State the possible damage to the material and describe how it could be prevented.

Possible damage .....

Method of prevention .....

[2]

10 Fig. 10.1 shows a wooden mould used to vacuum form a small tray.

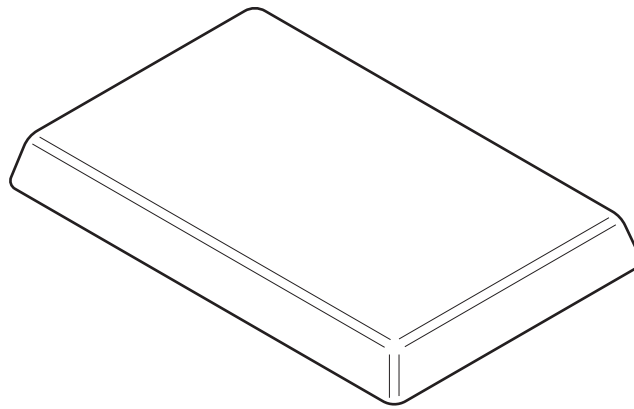

Fig. 10.1

(a) Give **two** advantages of making the mould from MDF rather than oak.

- 1 .....
- 2 ..... [2]

(b) Describe **two** features of the mould required to produce a quality vacuum formed tray.

- 1 .....
- 2 ..... [2]

**Section B**

Answer **one** question from this section.

- 11 Fig. 11.1 shows details of an incomplete design for an adjustable mirror made mainly from acrylic. Parts of the adjustable mirror will be batch produced in a school workshop using a laser cutter.

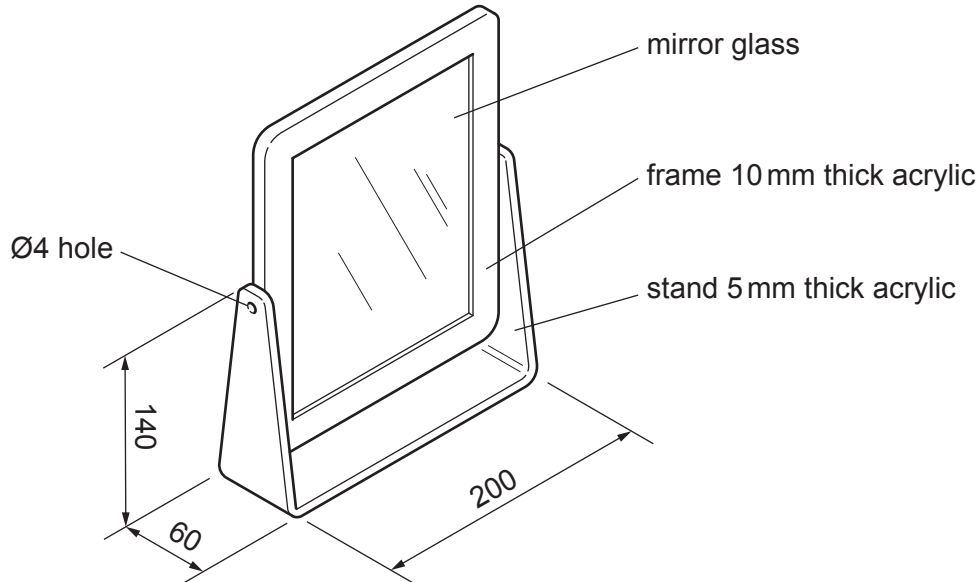

**Fig. 11.1**

- (a) Give **two** benefits of using acrylic to make the adjustable mirror.

- 1 .....
- 2 .....

[2]

- (b) The stand will be produced by means of a laser cutter.

Fig. 11.2 shows a screenshot of a CAD drawing of the development (net) of the stand.

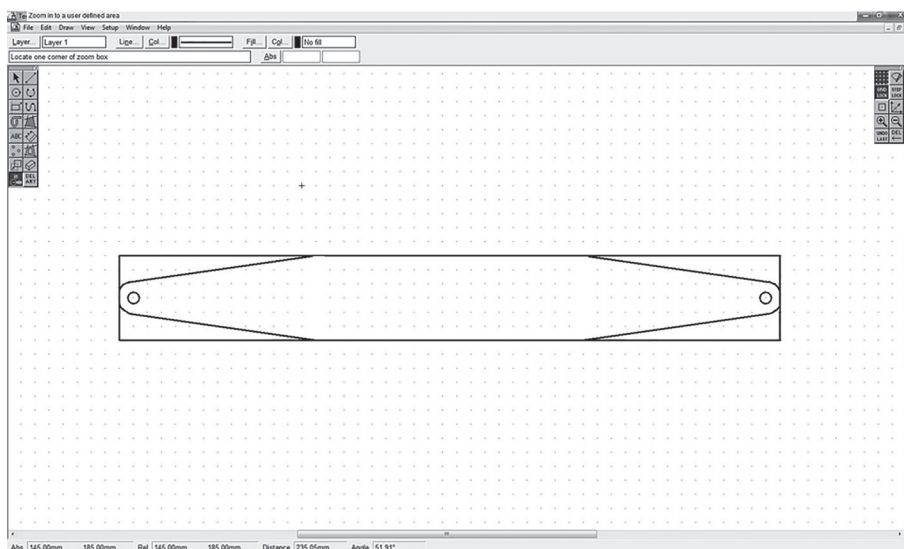

**Fig. 11.2**

- (i) Complete **five** stages of producing the acrylic stand using a laser cutter. The first one has been done for you.

1 Draw the development (net) of the stand design using CAD.

2 .....

3 .....

4 .....

5 .....

[4]

- (ii) Give **two** benefits, other than speed, of using a laser cutter to batch produce parts of the adjustable mirror.

1 .....

2 .....

[2]

- (c) After the development (net) of the stand has been cut out it will be bent to shape. Use sketches and notes to show how the acrylic stand could be bent to shape.

[3]



- (d) Fig. 11.3 shows views of part of the stand and mirror.  
The mirror will pivot inside the stand and must be able to be locked in position when adjusted.

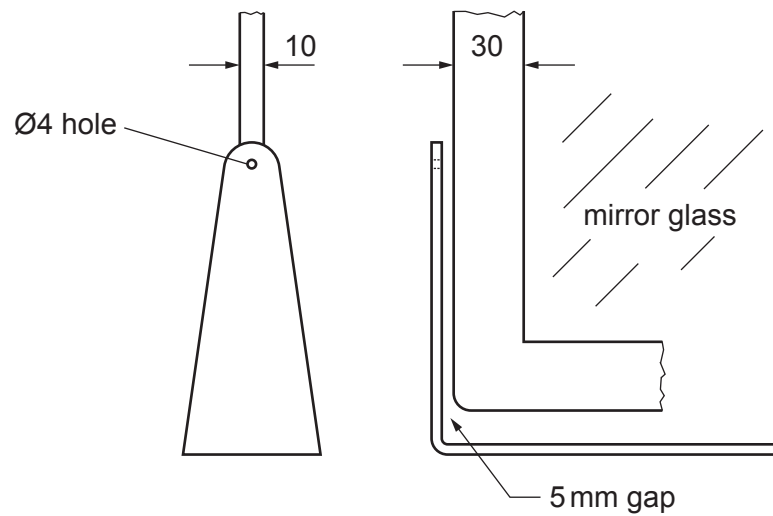

**Fig. 11.3**

Use sketches and notes to show a fitting that could be used to adjust the mirror and lock it in position.

The fitting must be adjustable by hand and be attractive.

Include details of materials and constructions used.

- (e) The stand could also be made from mild steel sheet.  
 Fig. 11.4 shows the development (net) of the stand made from 1.6 mm thick mild steel sheet.

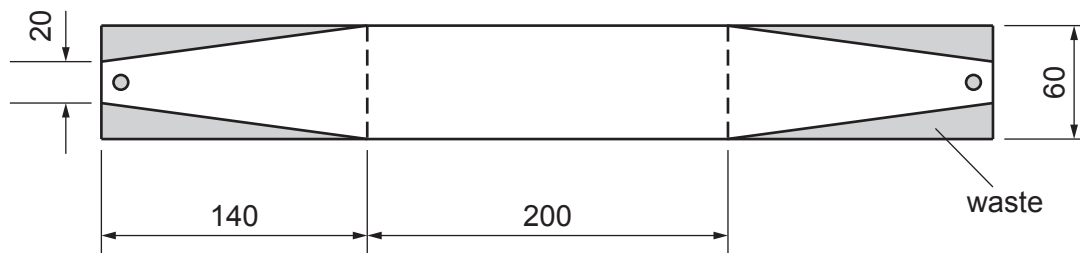

Fig. 11.4

Use sketches and notes to show how the stand could be cut out by hand and bent to shape.  
 Give the names of the tools and equipment used.

[6]

- (f) The stand made from mild steel sheet will have a spray painted finish.
- (i) Name **one** abrasive paper that could be used to prepare the surfaces to take a spray painted finish.

..... [1]

- (ii) Give **one** advantage of a spray painted finish rather than a painted finish applied by brush.

..... [1]

- 12 Fig. 12.1 shows a folding stool made from hardwood with a fabric seat. The stool will be used outdoors.

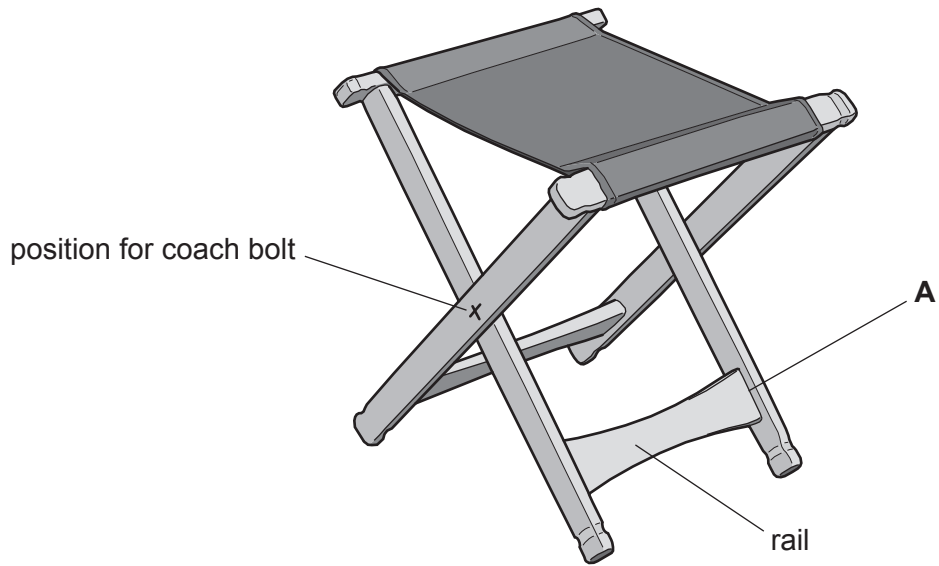

Fig. 12.1

- (a) Give **two** additional specification points for the folding stool. The folding stool must:

1 be comfortable to use

2 .....

3 .....

[2]

(b) Fig. 12.2 shows the shape of the rail marked out, ready to be cut out.

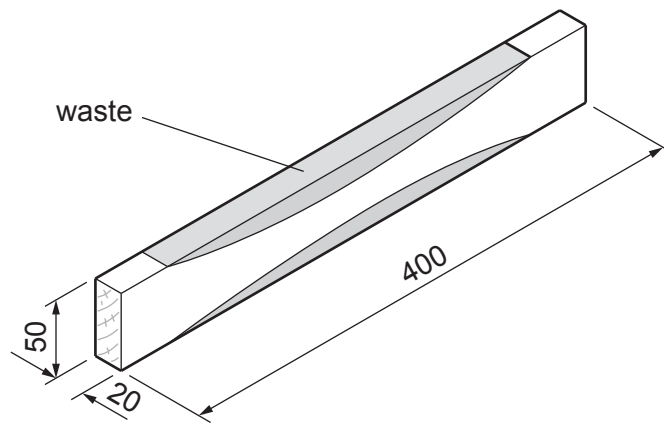

**Fig. 12.2**

Use sketches and notes to show how the curved shape could be produced.  
 Show how the rail could be held securely while the shape is produced.  
 Give the correct names of the tools and equipment used.

[4]

(c) Sketch and name a suitable construction that could be used to join the rail to the leg at **A** in Fig. 12.1.

Name of construction .....

[4]

(d) Fig. 12.3 shows a type of clamp that could be used when gluing a rail to the legs.

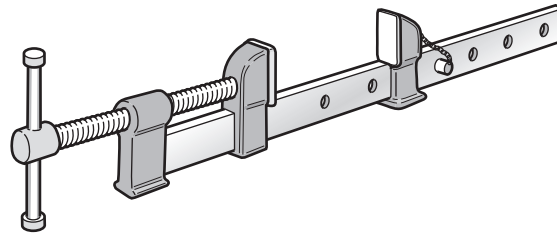

Fig. 12.3

(i) Name the type of clamp shown in Fig. 12.3.

..... [1]

(ii) Name an adhesive that would be suitable for use outdoors.

..... [1]

(iii) Use sketches and notes to show how the clamp in Fig. 12.3 could be used to clamp the rail to the legs while the adhesive sets.

[2]

(iv) State **two** checks that must be made when clamping the rail and legs together.

1 .....

2 .....

[2]

(e) Fig. 12.4 shows a coach bolt and nut.

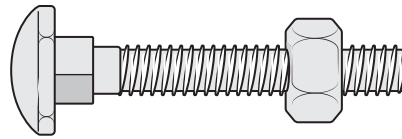

Fig. 12.4

Describe **one** benefit of using this type of fitting to join the legs together at the position shown in Fig. 12.1.

.....  
 ..... [2]

(f) Fig. 12.5 shows a folding stool made from Ø20 aluminium tube with a fabric seat.



Fig. 12.5

Give **two** properties of aluminium tube that make it suitable for the folding stool.

1 .....  
 2 ..... [2]

(g) State the purpose of the plastic 'foot' shown at **A** in Fig. 12.5.

..... [1]

(h) Fig. 12.6 shows the folding stool made from aluminium tube with the fabric seat removed.

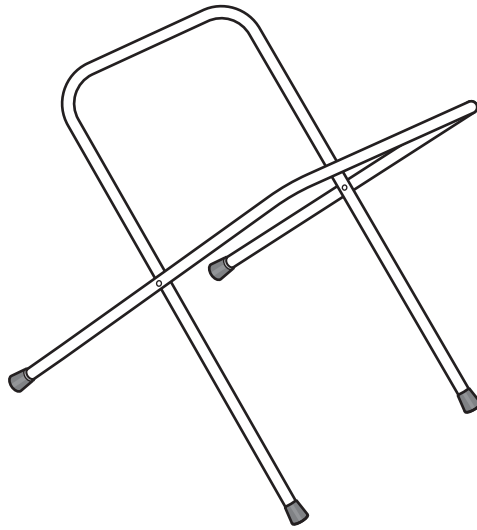

**Fig. 12.6**

Use sketches and notes to show a design for a moulded plastic seat that could be attached securely to the  $\text{Ø}20$  tube and allow the stool to be folded and carried.  
Name a specific plastic for the seat.

[4]

- 13 Fig. 13.1 shows a nesting box made from 15 mm thick softwood. A batch of twenty nesting boxes is to be made in a school workshop.

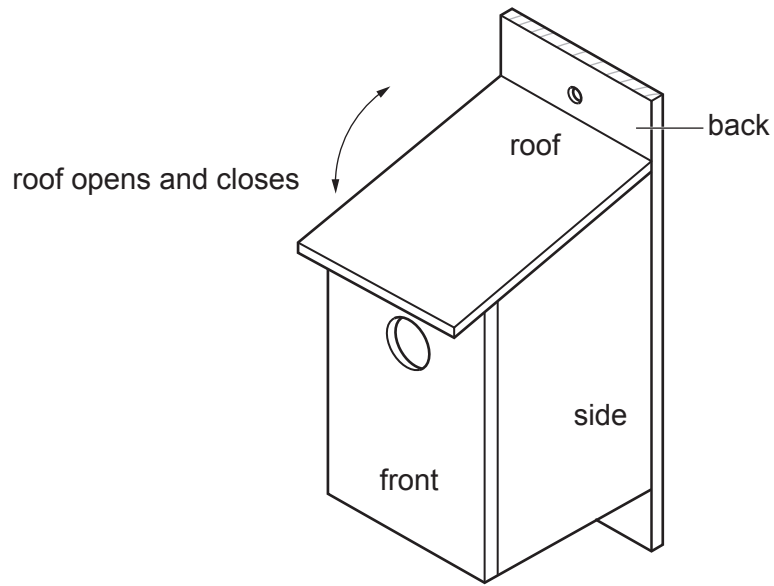

Fig. 13.1

- (a) (i) Name a suitable softwood for the nesting box.

..... [1]

- (ii) Give **one** reason for your choice of softwood.

..... [1]

- (b) Fig. 13.2 shows the parts of one nesting box marked out on a length of softwood.

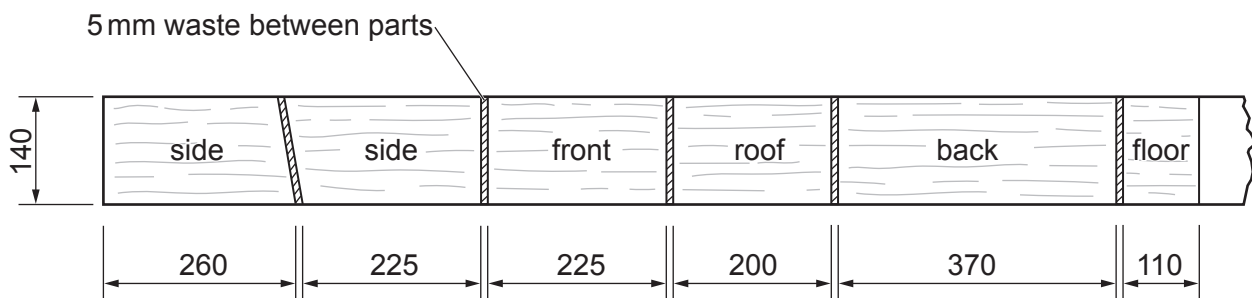

Fig. 13.2

- (i) Explain why 5 mm waste has been marked out between each of the parts.

.....  
 .....  
 ..... [2]



(ii) Name a machine saw that could be used to cut the parts to length.

..... [1]

(iii) Fig. 13.3 shows the front part of the nesting box after it has been cut from the length of softwood.

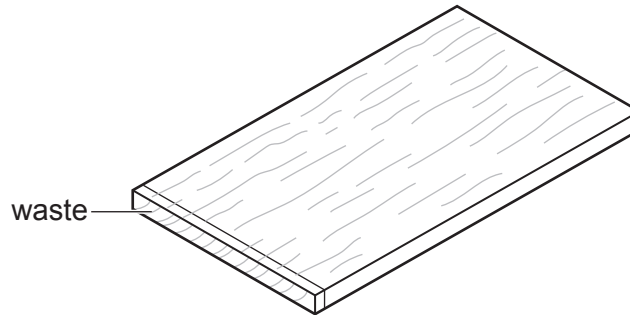

**Fig. 13.3**

Describe how the waste could be removed to produce flat and square ends.

.....  
.....  
..... [2]

(c) The front, back and sides of the nesting box will be glued and nailed together.

(i) Name a specific type of nail suitable to join the parts of the nesting box.

..... [1]

(ii) Name an adhesive that would be suitable outdoors.

..... [1]

(d) Fig. 13.4 shows the floor of the nesting box.

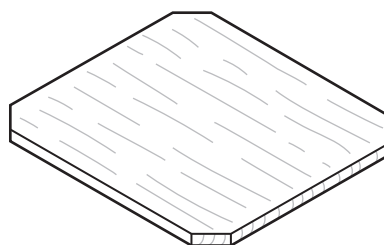

**Fig. 13.4**

Give **one** reason why the corners of the floor have been removed.

..... [1]

(e) A  $\text{Ø}40$  hole will be drilled in the front part of the nesting box.

(i) Name a suitable drill bit that could be used to drill the  $\text{Ø}40$  hole in the front part of the nesting box.

..... [1]

(ii) Use sketches and notes to show how the front part of the nesting box could be clamped in position while the  $\text{Ø}40$  hole is drilled.

[2]

(f) Use sketches and notes to show how the roof of the nesting box could be made to open and close as shown in Fig. 13.1.

[4]

(g) A batch of twenty nesting boxes is to be made in a school workshop. Use sketches and notes to show **two** jigs that could be used to speed up production of twenty identical nesting boxes.

1 Jig to speed up cutting.

[3]

2 Jig to speed up assembly.

[3]

(h) State **two** factors to consider when designing products that will be used outdoors.

1 .....

2 .....

[2]

**BLANK PAGE**

---

Permission to reproduce items where third-party owned material protected by copyright is included has been sought and cleared where possible. Every reasonable effort has been made by the publisher (UCLES) to trace copyright holders, but if any items requiring clearance have unwittingly been included, the publisher will be pleased to make amends at the earliest possible opportunity.

To avoid the issue of disclosure of answer-related information to candidates, all copyright acknowledgements are reproduced online in the Cambridge Assessment International Education Copyright Acknowledgements Booklet. This is produced for each series of examinations and is freely available to download at [www.cambridgeinternational.org](http://www.cambridgeinternational.org) after the live examination series.

Cambridge Assessment International Education is part of the Cambridge Assessment Group. Cambridge Assessment is the brand name of the University of Cambridge Local Examinations Syndicate (UCLES), which itself is a department of the University of Cambridge.