



Cambridge IGCSE™ (9–1)

CANDIDATE
NAME

CENTRE
NUMBER

--	--	--	--	--

CANDIDATE
NUMBER

--	--	--	--

DESIGN & TECHNOLOGY

0979/32

Paper 3 Resistant Materials

May/June 2021

1 hour

You must answer on the question paper.

No additional materials are needed.

INSTRUCTIONS

- Section A: answer **all** questions.
- Section B: answer **one** question.
- Use a black or dark blue pen. You may use an HB pencil for any diagrams or graphs.
- Write your name, centre number and candidate number in the boxes at the top of the page.
- Answer in the space provided.
- Do **not** use an erasable pen or correction fluid.
- Do **not** write on any bar codes.
- You may use a calculator.

INFORMATION

- The total mark for this paper is 50.
- The number of marks for each question or part question is shown in brackets [].
- All dimensions are in millimetres.

This document has **24** pages. Any blank pages are indicated.



Section A

Answer **all** questions in this section.

- 1 Fig. 1.1 shows a workshop operation where there is a danger of damaging the material.

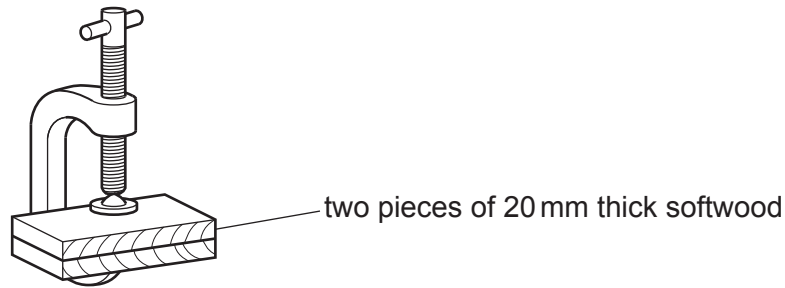

Fig. 1.1

State the possible damage to the material and describe how it could be prevented.

Possible damage

Method of prevention

[2]

- 2 Fig. 2.1 shows a photograph holder and two hardwood stands.

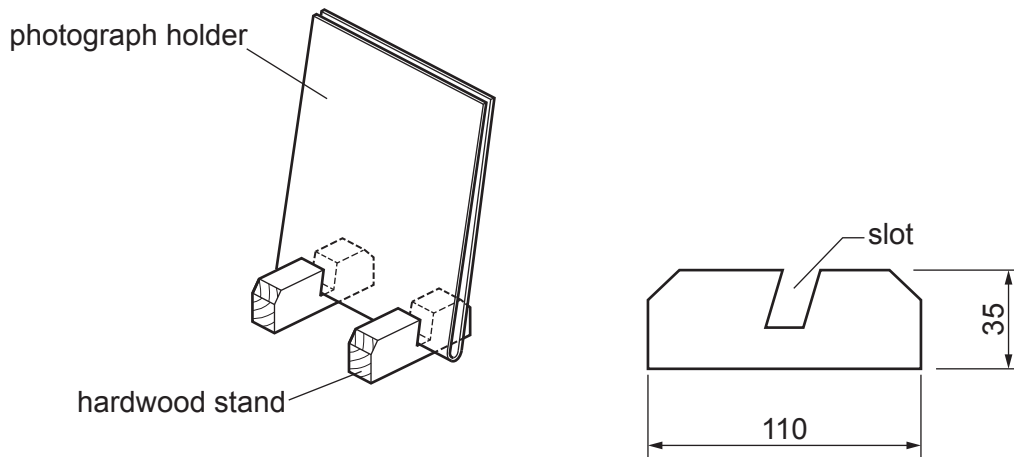

Fig. 2.1

Complete Table 2.1 by stating the purpose of each tool used to produce the hardwood stands.

Table 2.1

Tool	Purpose of tool
Sliding bevel	
Tenon saw	
Bevel-edge chisel	

[3]

3 Complete the statement below by adding the correct term from the list.

- soft flexible hard corrosion resistant**

Steel that contains a high amount of carbon is very [1]

4 Draw on Fig. 4.1 to show an exploded view of a tee-halving joint.

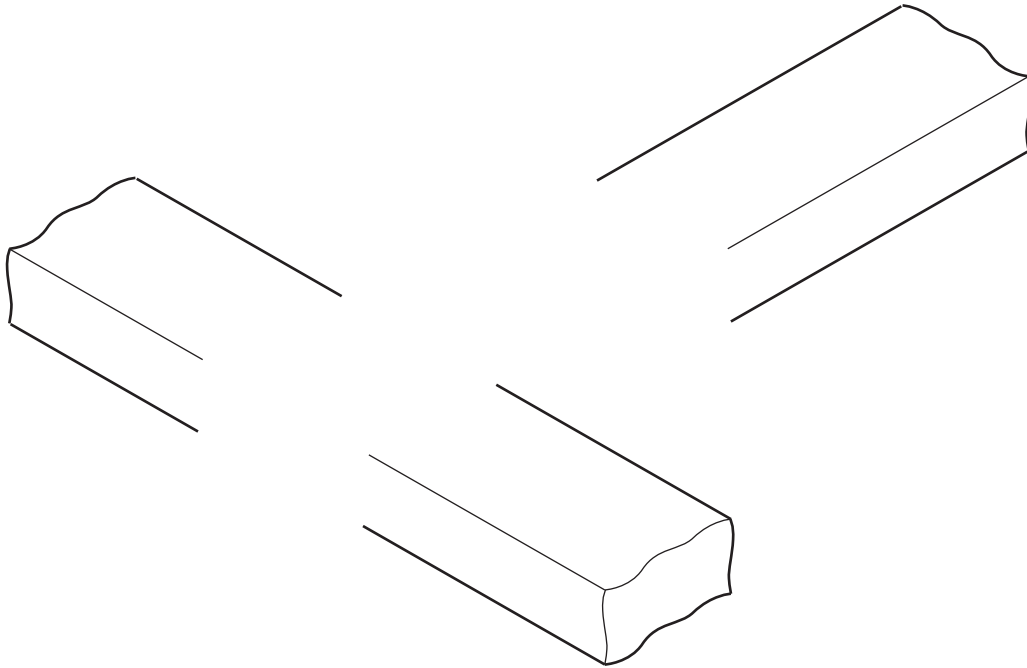

Fig. 4.1

[3]

5 Fig. 5.1 shows vacuum formed plastic sheets, **A** and **B**, that were formed using two different moulds. A fault known as 'webbing' has occurred to both sheets but for different reasons.

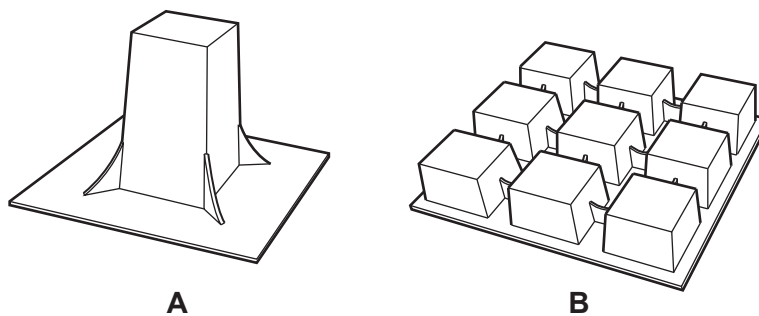

Fig. 5.1

Give **one** reason why webbing has occurred to:

Sheet **A**

Sheet **B**

[2]

6 Fig. 6.1 shows two lengths of 5 mm thick mild steel strip with pre-drilled holes.

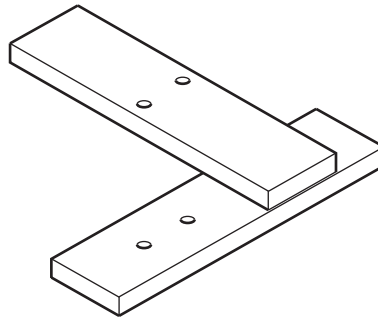

Fig. 6.1

Name different types of fastening that could be used in the pre-drilled holes to join the mild steel strips together:

temporarily

permanently

[2]

7 Fig. 7.1 shows three holes, **A**, **B** and **C**, drilled through 5 mm thick plywood.

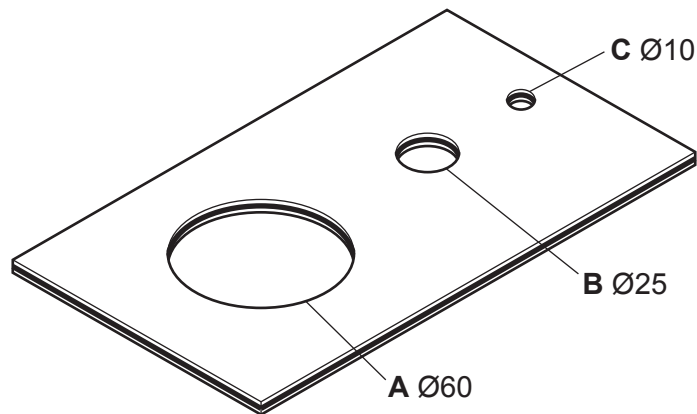

Fig. 7.1

(a) Name different types of drill bit that could be used to drill each of the holes.

Hole **A**

Hole **B**

Hole **C**

[3]

(b) State **one** danger that could occur when drilling thin plywood.

..... [1]

- 8 Complete Table 8.1 by stating the manufacturing process used to make each product.

Table 8.1

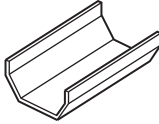
Product	Material	Manufacturing process
 Model toy car	aluminium alloy	
 Guttering	UPVC	

[2]

- 9 Fig. 9.1 shows two lengths of softwood, **A** and **B**.
 Draw on **A** to show a rebate.
 Draw on **B** to show a groove.

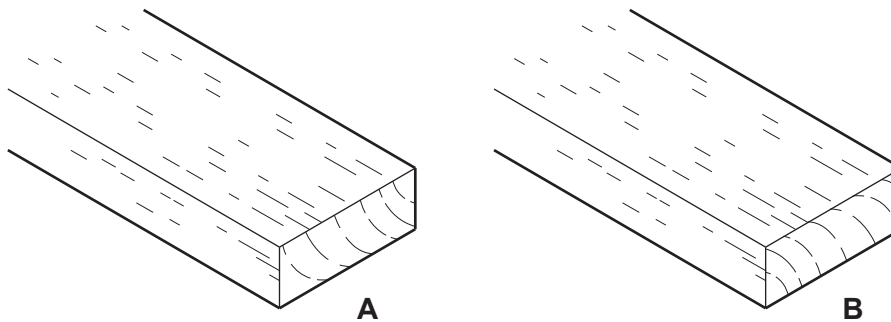

Fig. 9.1

[4]

10 Fig. 10.1 shows equipment used to apply an attractive finish on an aluminium product.

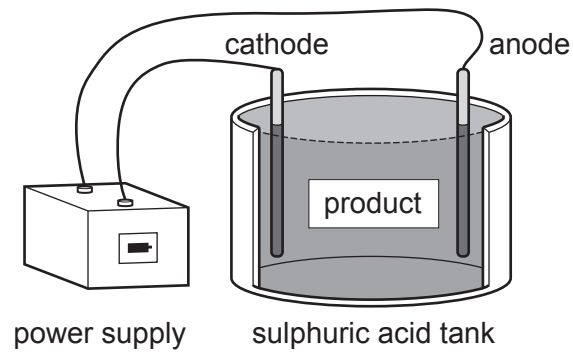

Fig. 10.1

(a) Name the process shown in Fig. 10.1.

..... [1]

(b) Give **one** reason, other than an attractive appearance, why a finish would be applied to a product made from metal.

..... [1]

Section B

Answer **one** question from this section.

11 Fig. 11.1 shows a table made from oak with a detachable magazine rack made from acrylic.

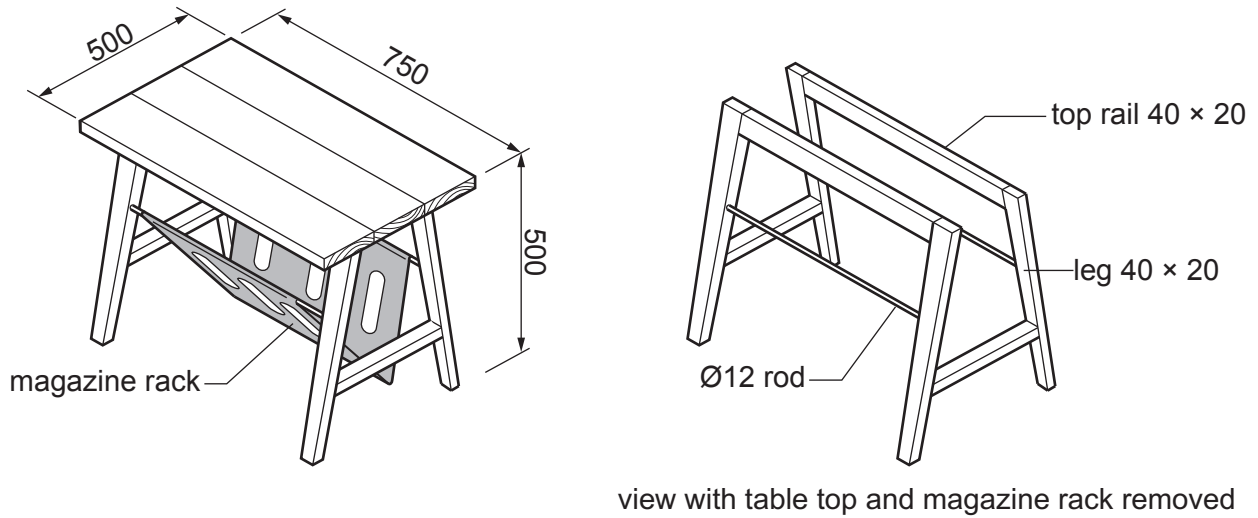

Fig. 11.1

(a) Give **two** reasons why oak is a suitable hardwood from which to make the table.

1

2

[2]

(b) The table top is constructed from three separate boards.
Fig. 11.2 shows the end of the table top.

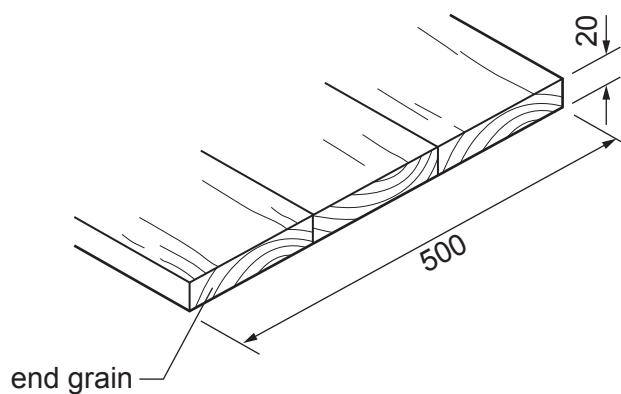

Fig. 11.2

(i) Give **one** reason why the table top is constructed from three boards rather than one board 500 mm wide.

..... [1]

(ii) Explain why the boards have been arranged as shown by the end grain.

.....

.....

..... [2]

(c) Fig. 11.3 shows a brass plate screwed into the top rail. The oak table top will be fixed to the top rail by means of a screw inserted from underneath the brass plate. The hole to take the screw is slotted.

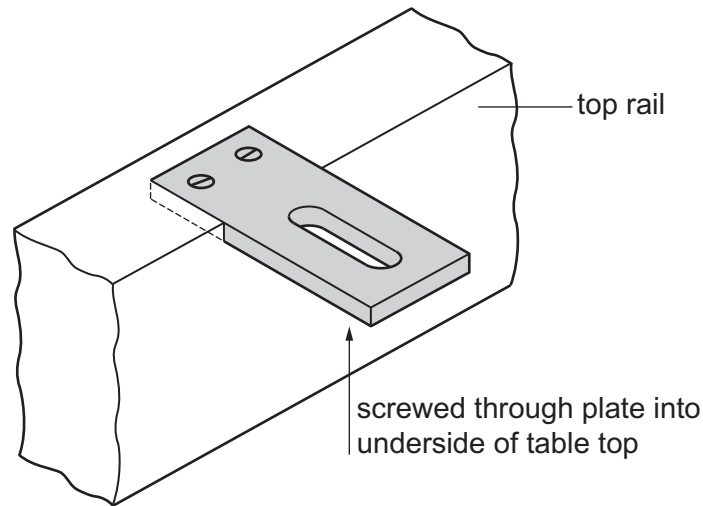

Fig. 11.3

Explain why the hole for the screw that goes into the table top is slotted.

.....

.....

..... [2]

(d) The legs and top rails are joined together by means of glued dowel joints. Fig. 11.4 shows one of the dowels that will be used.



Fig. 11.4

State the purpose of:

(i) the grooves

.....

(ii) the chamfer.

.....

[2]

(e) Fig. 11.5 shows details of a jig that could be used to mark out the positions for the dowels on the ends of the top rails and legs. The jig is made from 1 mm thick mild steel sheet. The jig fits neatly over the end of the top rails and legs.

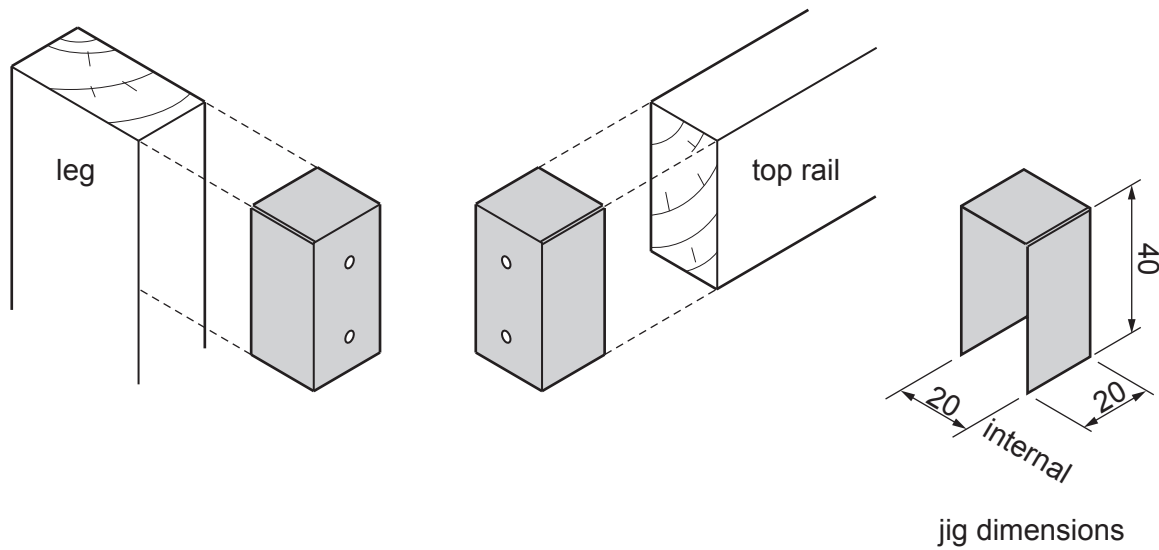

Fig. 11.5

Fig. 11.6 shows the development (net) of the dowel jig marked out, ready to be cut to shape.

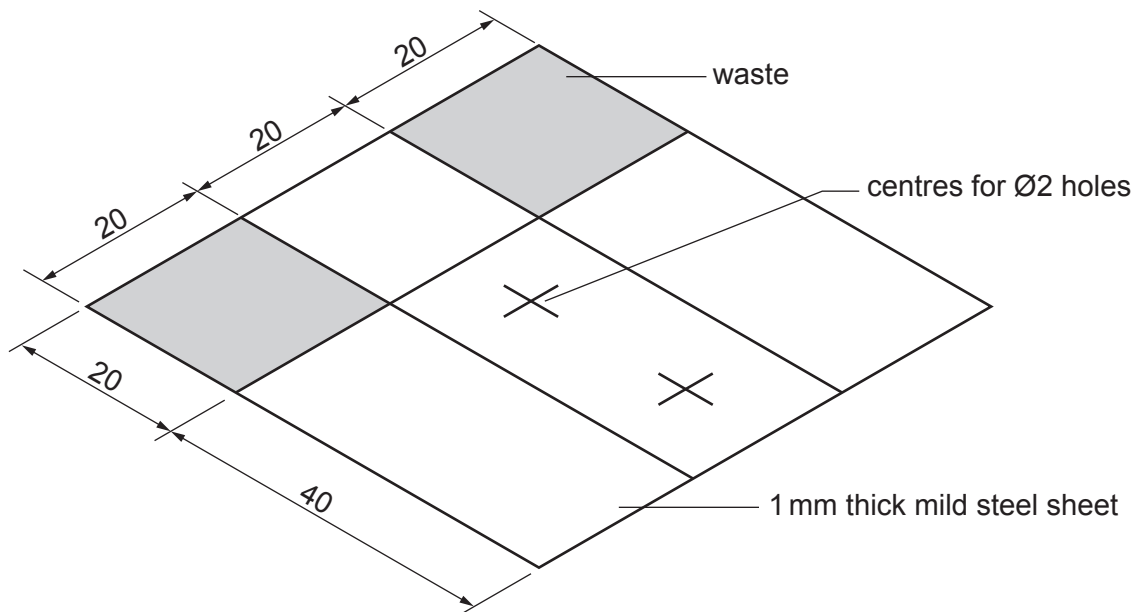

Fig. 11.6

(i) Name **two** marking out tools that could be used to mark out the development (net).

- 1
 - 2
- [2]

(ii) Give **one** reason why a centre punch would be used before drilling holes in the mild steel sheet.

..... [1]

- (iii) Use sketches and notes to show how the development (net) could be cut out.
Name all the tools and equipment used.

[3]

- (iv) Use sketches and notes to show how the cut out development (net) could be bent to shape.
Name all the tools and equipment used.

[4]

- (f) The magazine rack is made from 4 mm thick acrylic sheet. Fig. 11.7 shows a CAD screenshot of the magazine rack that will be cut out using a laser cutter.

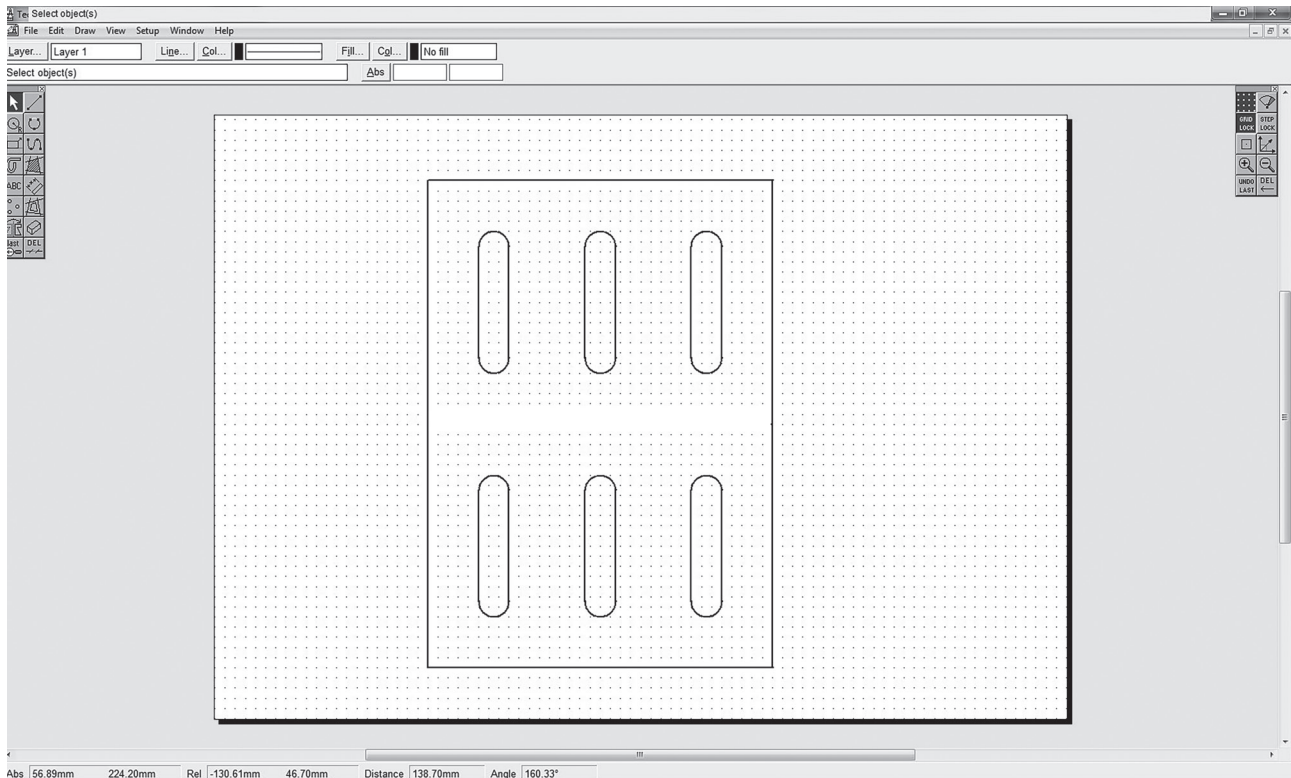

Fig. 11.7

Complete Table 11.1 by adding **three** stages when cutting out the magazine rack using a laser cutter.

Table 11.1

Stages	Action to be taken
1	Set up sheet on laser cutter bed
2	
3	
4	
5	Remove acrylic from laser cutter bed

[3]

12

- (g) Fig. 11.8 shows an end view of the magazine rack.
The two edges are curved to fit over $\text{Ø}12$ rod.

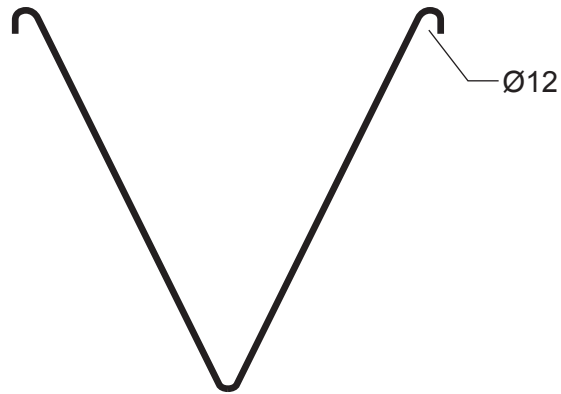

Fig. 11.8

Use sketches and notes to show how the $\text{Ø}12$ curves could be produced along the two edges.

[3]

12 Fig. 12.1 shows a storage unit with adjustable shelves that will be used in a bathroom. The storage unit is made from acrylic and could be produced in a school workshop by means of hand tools and CAD/CAM.

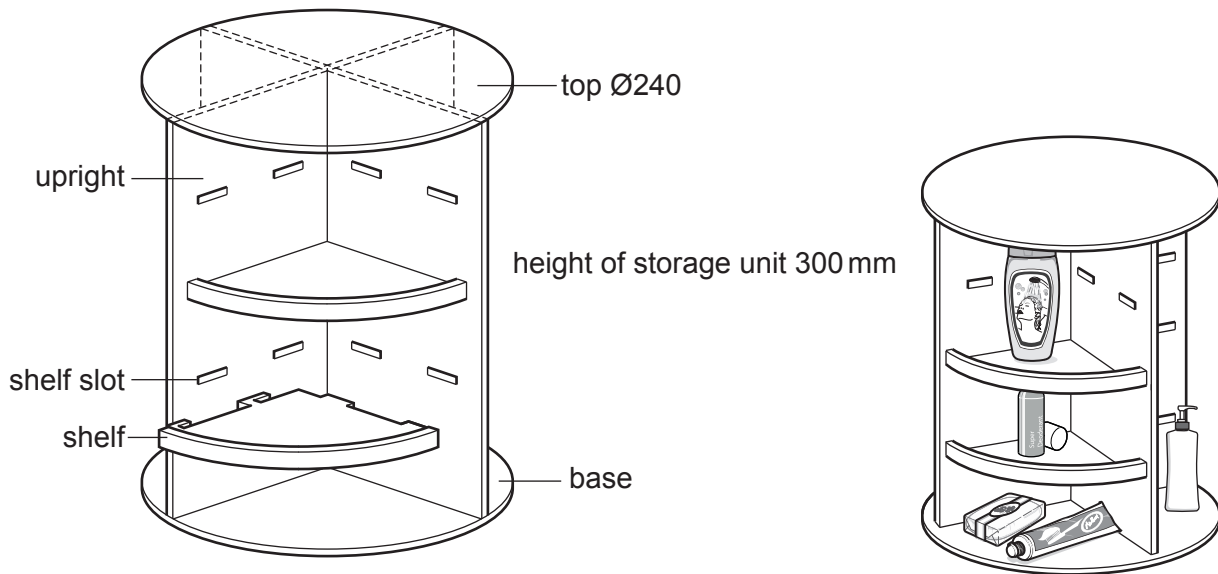

Fig. 12.1

(a) Give **two** benefits of using acrylic to make products that will be used in a bathroom.

- 1
 - 2
- [2]

(b) State **two** important items of information that could be obtained by making **either** a card model **or** computer-generated model of the storage unit.

- 1
 - 2
- [2]

(c) The shelf slots will be cut out of the uprights. Describe how CAD/CAM could be used to produce the shelf slots quickly and accurately.

-
 -
 -
 -
 -
 -
- [4]

(d) Fig. 12.2 shows how the two uprights slot together to produce the main part of the storage unit.

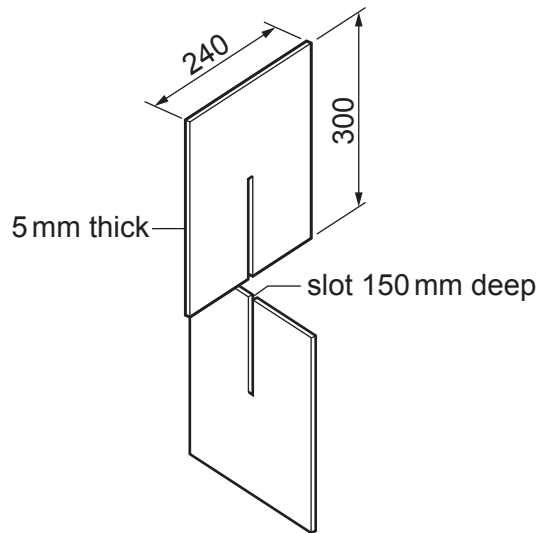

Fig. 12.2

Give **two** benefits, other than speed, of using a scroll saw to cut out the slots.

1

2

[2]

(e) Fig. 12.3 shows details of one shelf and a separate edging that will be joined to the front edge of the shelf.

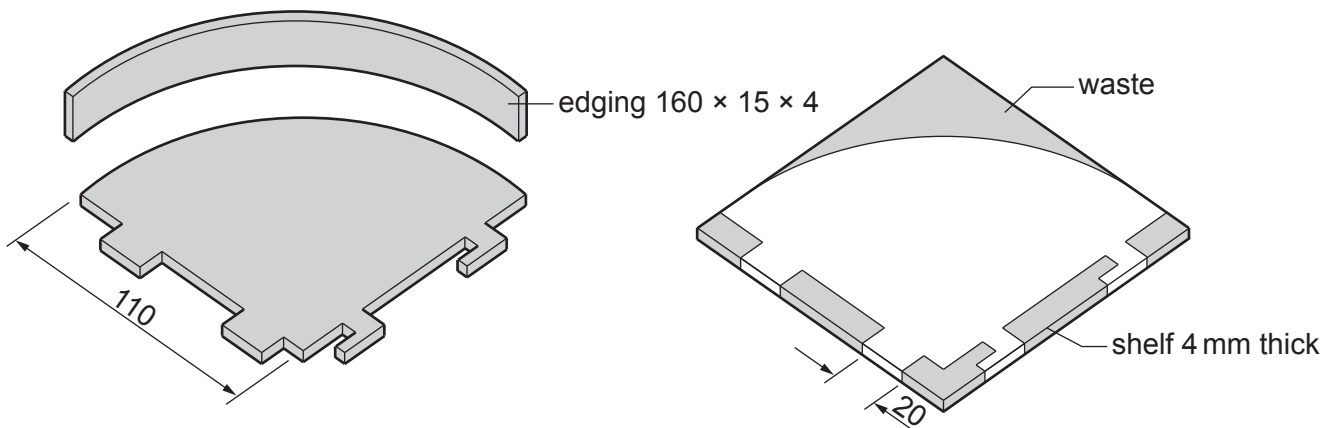

Fig. 12.3

(i) Name **two** hand tools that could be used to produce the shelf.

1

2

[2]

- (ii) The edging will be made from a length of acrylic.
The acrylic will be heated and bent to match the curved front edge of the shelf.
Explain why the acrylic would be heated in an oven rather than by a strip heater or line bender.

.....
.....
..... [2]

- (iii) The edging will be joined to the front edge using acrylic cement.
Use sketches and notes to show how the edging could be held securely against the front edge of the shelf while the acrylic cement sets.

[4]

- (iv) State **one** safety precaution that must be taken when using acrylic cement.
..... [1]

- (f) The items stored in the unit could be made easier to access if the unit could be made to rotate. Use sketches and notes to show how an additional base could be used to make the storage unit rotate. Give details of the materials and constructions used.

[6]

- 13 Fig. 13.1 shows an incomplete design for a novelty adjustable lamp made from hardwood. The lampshade has been removed to show the neck of the lamp.

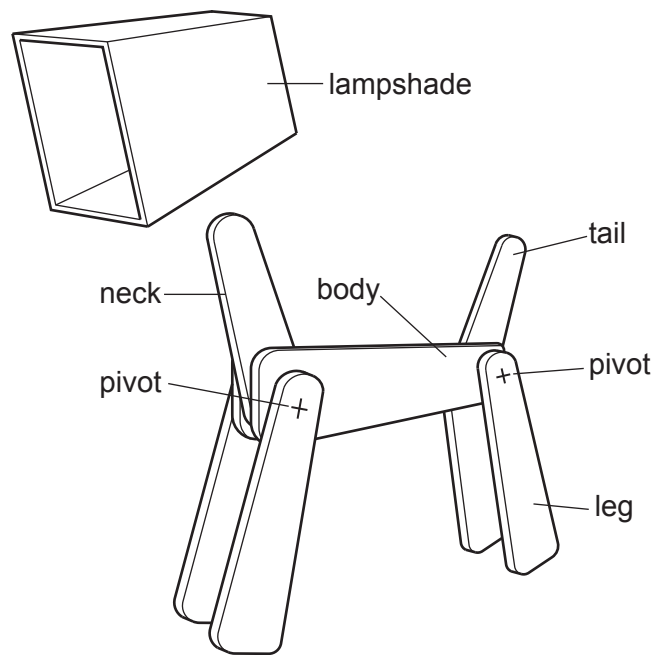

Fig. 13.1

Table 13.1 shows a parts list for the adjustable lamp.

Table 13.1

Part	No. reqd.	Length × Width × Thickness
body	2	230 × 60 × 15
leg	4	200 × 50 × 15
tail	1	120 × 40 × 15
neck	1	160 × 50 × 15

- (a) Name a suitable hardwood for the adjustable lamp.

..... [1]

- (b) Give **two** items of information that could be obtained by designing a computer-generated model of the adjustable lamp.

1

2

[2]

(c) Fig. 13.2 shows the length of hardwood that will be used for the tail.

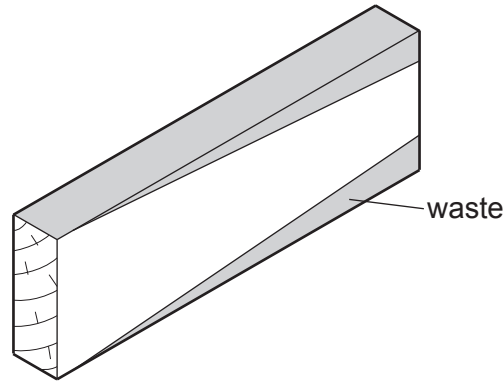

Fig. 13.2

(i) Name a type of plane that could be used to remove the waste wood.

..... [1]

(ii) Use sketches and notes to show how the length of hardwood could be held in a vice while being planed.

[2]

(d) The parts of the adjustable lamp will have a clear finish applied to them before they are assembled.

(i) Describe how the surfaces of the hardwood parts would be prepared before a clear finish is applied.

.....
.....
..... [2]

(ii) Name a suitable clear finish for the hardwood parts.

..... [1]

(iii) Give **two** advantages of a clear finish rather than a painted finish for the hardwood.

1

2

[2]

(e) Fig. 13.3 shows the rear legs, body and tail that will be joined by means of a threaded metal rod.

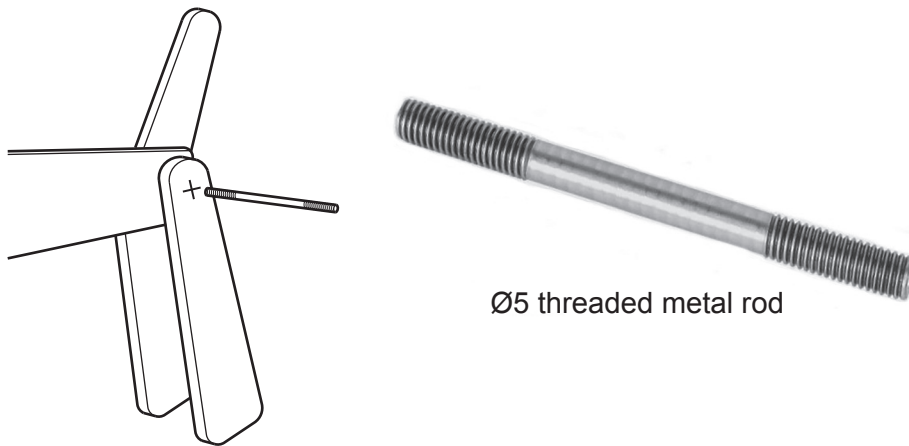

Fig. 13.3

Use sketches and notes to show how the threaded metal rod could be used to allow the hardwood parts to be tightened and loosened by hand without the aid of additional tools.

[4]

- (f) Fig. 13.4 shows details of the lampshade made from 4 mm thick veneered plywood. The back of the lampshade has been removed.

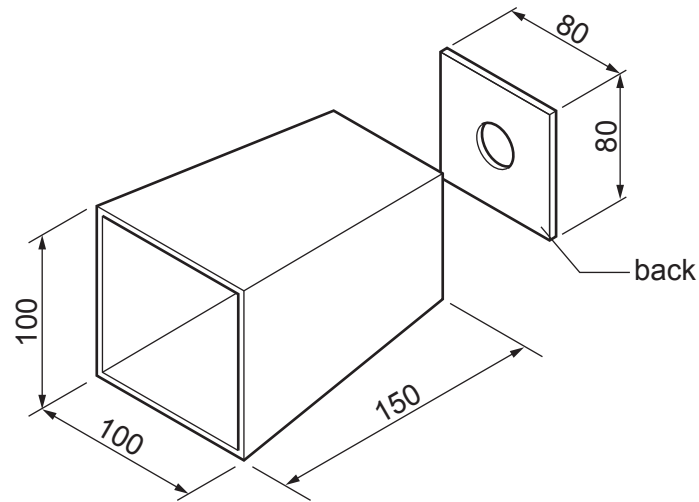

Fig. 13.4

- (i) Give **two** advantages of using veneered plywood rather than solid wood for the lampshade.

1

2

[2]

- (ii) The lampshade is made from veneered plywood which is **only** 4 mm thick. Use sketches and notes to show how the lampshade, including the back, could be constructed. Include details of any additional materials used.

[4]

- (g) Fig. 13.5 shows the lampshade that will be joined to the neck and allowed to move as shown when adjusted.

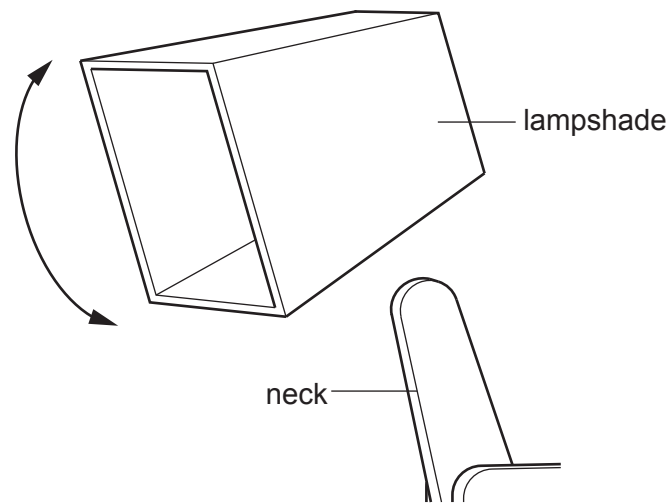

Fig. 13.5

Use sketches and notes to show a modification to the lampshade to enable it to be joined to the neck and allowed to move as shown.
Include details of materials and constructions used.

BLANK PAGE

Permission to reproduce items where third-party owned material protected by copyright is included has been sought and cleared where possible. Every reasonable effort has been made by the publisher (UCLES) to trace copyright holders, but if any items requiring clearance have unwittingly been included, the publisher will be pleased to make amends at the earliest possible opportunity.

To avoid the issue of disclosure of answer-related information to candidates, all copyright acknowledgements are reproduced online in the Cambridge Assessment International Education Copyright Acknowledgements Booklet. This is produced for each series of examinations and is freely available to download at www.cambridgeinternational.org after the live examination series.

Cambridge Assessment International Education is part of the Cambridge Assessment Group. Cambridge Assessment is the brand name of the University of Cambridge Local Examinations Syndicate (UCLES), which itself is a department of the University of Cambridge.