



Cambridge International Examinations
Cambridge International General Certificate of Secondary Education

CANDIDATE
NAME

CENTER
NUMBER

--	--	--	--	--

CANDIDATE
NUMBER

--	--	--	--



MATHEMATICS (US)

0444/31

Paper 3 (Core)

May/June 2015

2 hours

Candidates answer on the Question Paper.

Additional Materials: Geometrical instruments
 Electronic calculator

READ THESE INSTRUCTIONS FIRST

Write your Center number, candidate number and name on all the work you hand in.
Write in dark blue or black pen.
You may use an HB pencil for any diagrams or graphs.
Do not use staples, paper clips, glue or correction fluid.
DO NOT WRITE IN ANY BARCODES.

Answer **all** questions.
If work is needed for any question it must be shown in the space provided.
Electronic calculators should be used.
If the degree of accuracy is not specified in the question, and if the answer is not exact, give the answer to three significant digits.
Give answers in degrees to one decimal place.
For π , use either your calculator value or 3.142.

The number of points is given in parentheses [] at the end of each question or part question.
The total of the points for this paper is 104.

Write your calculator model in the box below.

This document consists of **16** printed pages.

Formula List

Area, A , of triangle, base b , height h .

$$A = \frac{1}{2}bh$$

Area, A , of circle, radius r .

$$A = \pi r^2$$

Circumference, C , of circle, radius r .

$$C = 2\pi r$$

Lateral surface area, A , of cylinder of radius r , height h .

$$A = 2\pi r h$$

Surface area, A , of sphere of radius r .

$$A = 4\pi r^2$$

Volume, V , of prism, cross-sectional area A , length l .

$$V = Al$$

Volume, V , of cylinder of radius r , height h .

$$V = \pi r^2 h$$

Volume, V , of sphere of radius r .

$$V = \frac{4}{3}\pi r^3$$

1 (a) Write down

(i) two factors of 12,

Answer(a)(i)

(ii) the next prime number after 19,

Answer(a)(ii) [1]

(iii) the cube root of 64,

Answer(a)(iii) [1]

(iv) two million five hundred and seven in figures,

Answer(a)(iv) [1]

(v) two multiples of 75,

Answer(a)(v) [1]

(vi) the value of π correct to 5 significant digits.

Answer(a)(vi) [1]

(b) Write as a percentage.

(i) 1.63

Answer(b)(i) % [1]

(ii) $\frac{3}{40}$

Answer(b)(ii) % [1]

(c) (i) Write 63 521.769 correct to 1 decimal place.

Answer(c)(i) [1]

(ii) Write 63 521.769 correct to the nearest hundred.

Answer(c)(ii) [1]

(d) (i) Change 234 mm into meters.

Answer(d)(i) m [1]

(ii) Change 876 m² into square centimeters.

Answer(d)(ii) cm² [1]

2 Sonia works in a toy shop.

(a) (i) One week she works for 30 hours and is paid \$180.

Calculate the amount she is paid per hour.

Answer(a)(i) \$..... [1]

(ii) The next week Sonia works for 38 hours and is paid \$220.

Find the difference in her pay per hour for these two weeks.

Answer(a)(ii) \$..... [2]

(b) The shop sells bags of 40 marbles.

One bag has marbles in the ratio red : blue : green = 1 : 3 : 4.

(i) Calculate the number of marbles of each color.

Answer(b)(i) Red = , blue = , green = [2]

(ii) A second bag of 40 marbles contains 11 red marbles, 9 blue marbles and 20 green marbles.

All the marbles from the two bags are mixed together.

Write down the ratio of marbles red : blue : green.

Give your answer in its simplest form.

Answer(b)(ii) : : [2]

(c) Thilo and Toby buy some boats and trains from the toy shop.
The cost of one boat is b cents and the cost of one train is t cents.

(i) Toby buys 3 boats and 4 trains for \$5.70 .

Complete this equation.

$$3b + 4t = \dots\dots\dots$$

[1]

(ii) Thilo buys 1 boat and 2 trains for \$2.40 .

Write this information as an equation.

$$\dots\dots\dots = \dots\dots\dots$$

[2]

(iii) Solve your two equations to find the cost of a boat and the cost of a train.
You must show all your working.

Answer(c)(iii) Cost of a boat = cents

Cost of a train = cents [3]

(d) Train track costs 99 cents per 20 cm.

Calculate the cost of buying 3.4 meters of train track.

Answer(d) \$ [3]

3 The Patel family flies from their home town, *H*, to Kiruna, *K*, in Lapland.

(a) The scale drawing shows their journey.
The scale is 1 centimeter represents 40 kilometers.

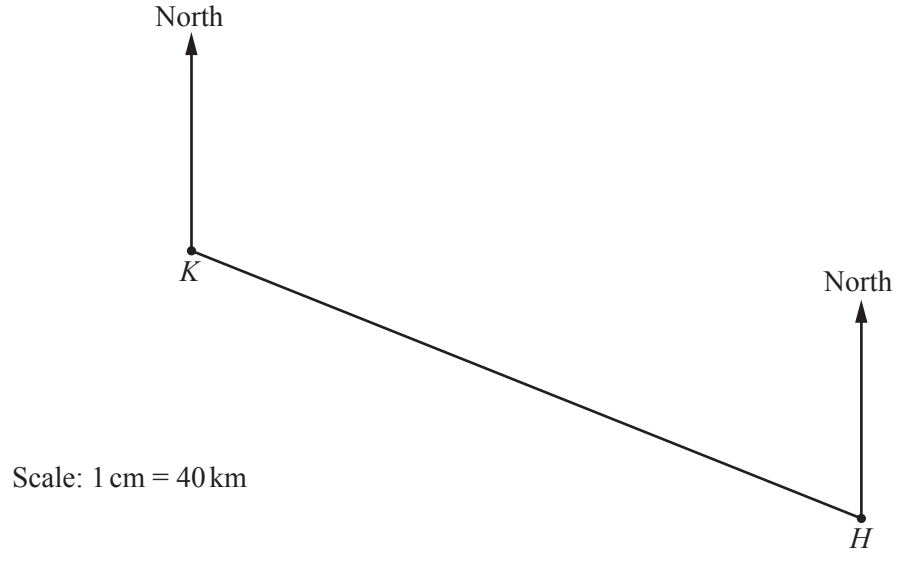

(i) Measure the bearing of *K* from *H*.

Answer(a)(i) [1]

(ii) Work out the distance in kilometers from *H* to *K*.

Answer(a)(ii) km [2]

(iii) The average speed of the plane is 450 km/h.

Find the average speed in m/s.

Answer(a)(iii) m/s [2]

(b) The probability that the plane arrives on time is 0.15 .

(i) Write down the probability that the plane does **not** arrive on time.

Answer(b)(i) [1]

(ii) Every year there are 240 flights from *H* to *K*.

Calculate the expected number of flights that arrive on time.

Answer(b)(ii) [1]

(c) The Patel family has six suitcases.
The number of items in each suitcase is shown below.

15 16 16 18 19 21

(i) Find the range.

Answer(c)(i) [1]

(ii) Write down the mode.

Answer(c)(ii) [1]

(iii) Work out the median.

Answer(c)(iii) [1]

(iv) Calculate the mean.

Answer(c)(iv) [2]

(v) Find the probability that a suitcase chosen at random has more than 18 items.

Answer(c)(v) [1]

(d) Mr Patel buys a bag of sweets.
The bag of sweets costs \$3.25 .

Calculate the cost of the sweets in euros (€) when the exchange rate is €1 = \$1.24 .

Answer(d) € [2]

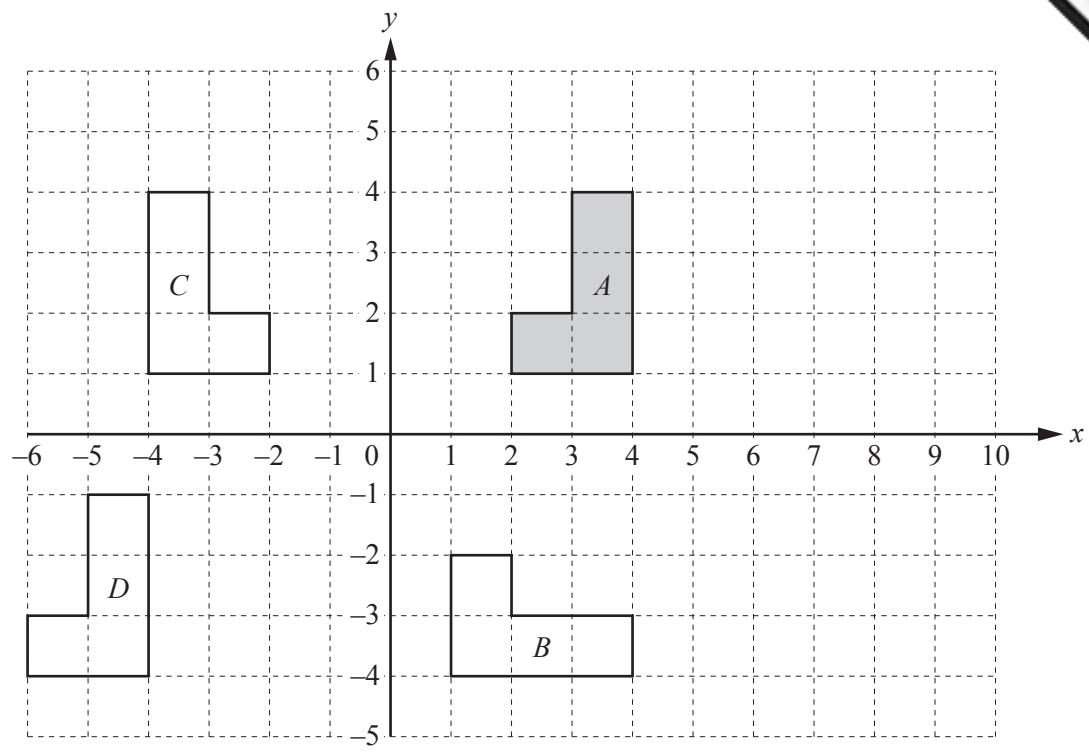

The diagram shows four shapes *A*, *B*, *C* and *D*.

(a) Describe fully the **single** transformation that maps **shape A** onto

(i) shape *B*,

Answer(a)(i) [3]

(ii) shape *C*,

Answer(a)(ii) [2]

(iii) shape *D*.

Answer(a)(iii) [2]

(b) On the grid, draw the enlargement of **shape A** by scale factor 2 and center $(-1, 2)$. [2]

5

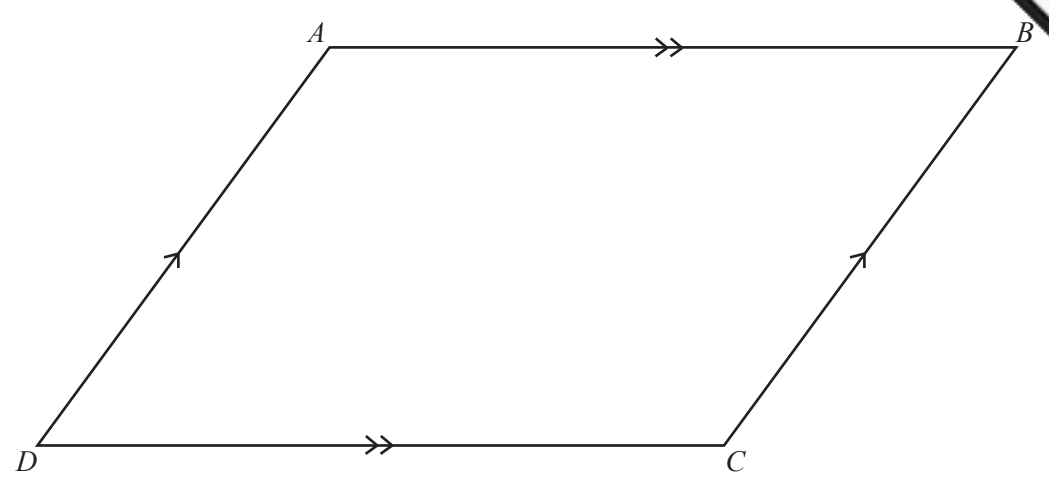

ABCD is a parallelogram.

(a) Write down

(i) the order of rotational symmetry of ABCD,

Answer(a)(i) [1]

(ii) the number of lines of symmetry of ABCD,

Answer(a)(ii) [1]

(iii) the sum of the interior angles of ABCD.

Answer(a)(iii) [1]

(b) (i) Complete this part using a compass and straight edge only. All construction arcs must be clearly shown.

On the diagram, construct the bisector of angle BAD. Extend this bisector to cut DC at E. Mark E on your diagram. [2]

(ii) Edelgard knows that angle BAE is the same size as angle AED.

Explain how Edelgard knows this is true without measuring the angles.

Answer(b)(ii) [1]

(iii) Write down the mathematical name for the triangle ADE and give a reason for your answer.

Answer(b)(iii) Name because [2]

(iv) Write down the mathematical name of the quadrilateral ABCE.

Answer(b)(iv) [1]

6 (a)

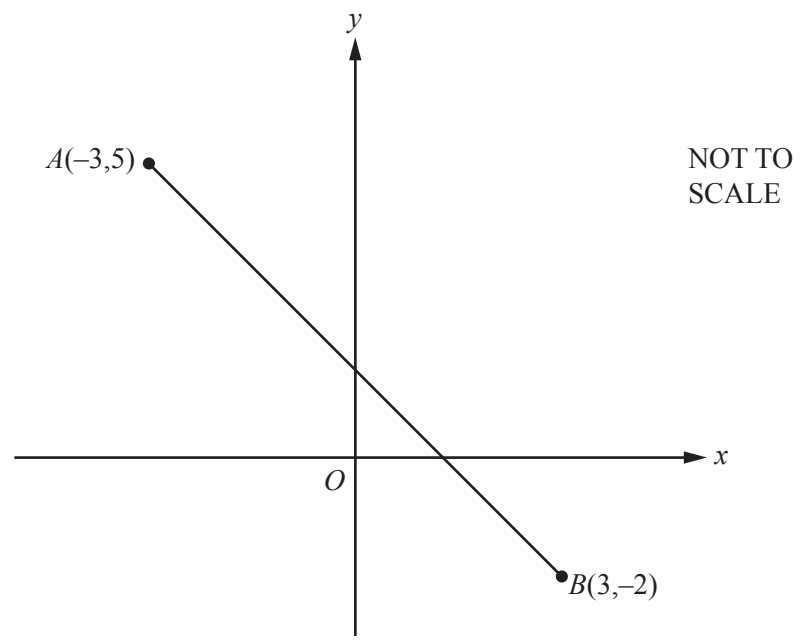

The diagram shows the line AB .

(i) Find the co-ordinates of the midpoint of the line AB .

Answer(a)(i) (..... ,) [2]

(ii) Write \vec{AB} as a column vector.

Answer(a)(ii) $\begin{pmatrix} \\ \end{pmatrix}$ [1]

(iii) $\vec{AC} = \begin{pmatrix} 5 \\ -2 \end{pmatrix}$

Write down the co-ordinates of C .

Answer(a)(iii) (..... ,) [1]

11

(b) (i)

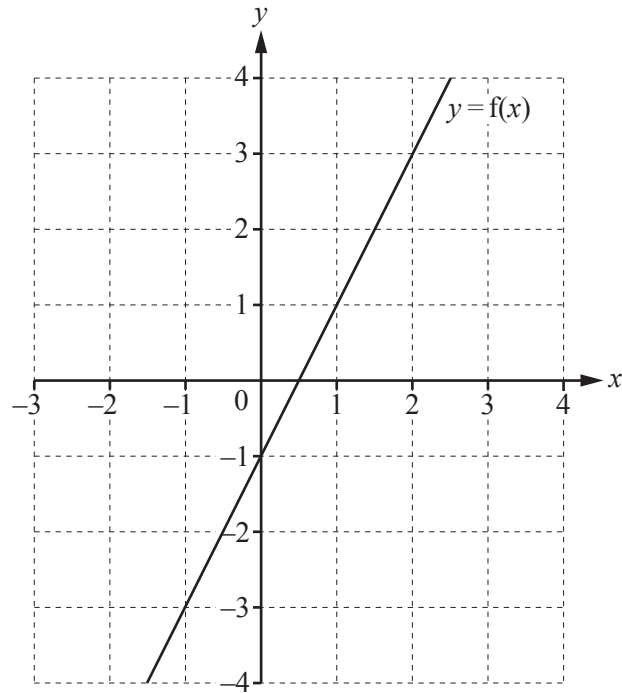

The graph of $y = f(x)$ is shown on the grid.

On this grid, draw the graph of $y = f(x) + 2$.

[2]

(ii)

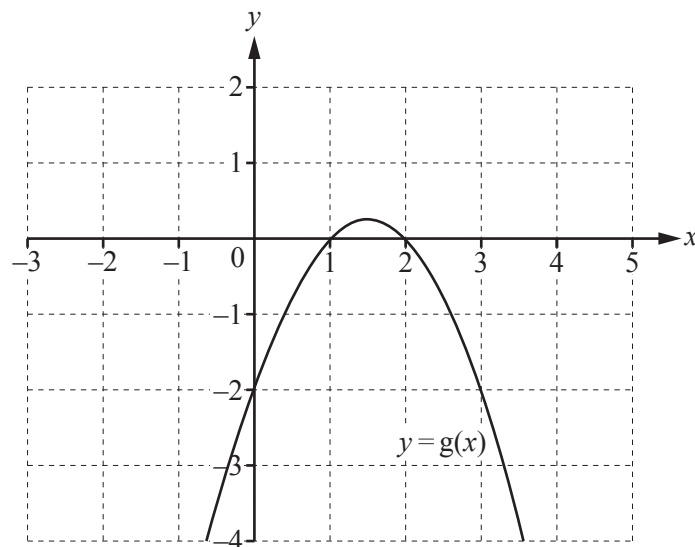

The graph of $y = g(x)$ is shown on the grid.

On this grid, draw the graph of $y = g(x + 1)$.

[2]

7 (a)

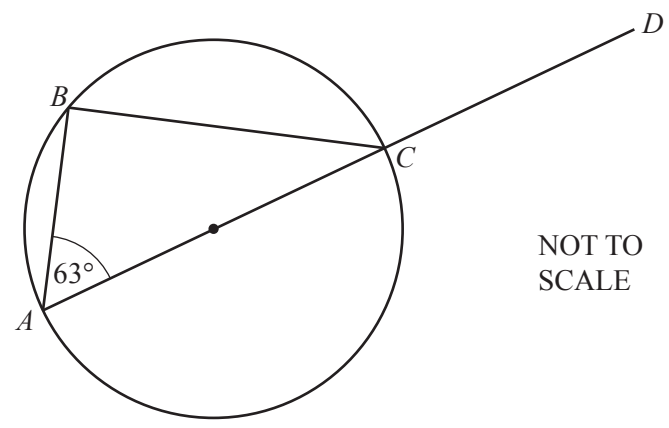

A, B and C lie on a circle with diameter AC .
 AC is extended to D and angle $BAC = 63^\circ$.

Work out angle BCD .
 Give reasons to explain your answer.

Answer(a) Angle $BCD = \dots\dots\dots$ because $\dots\dots\dots$
 $\dots\dots\dots$
 $\dots\dots\dots$ [4]

(b)

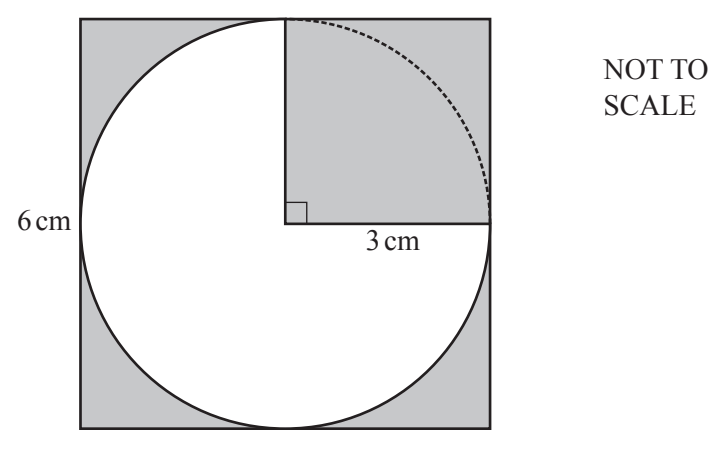

The diagram shows a circle with radius 3 cm inside a square of side 6 cm.
 Calculate the shaded area.

Answer(b) $\dots\dots\dots$ cm² [5]

(c)

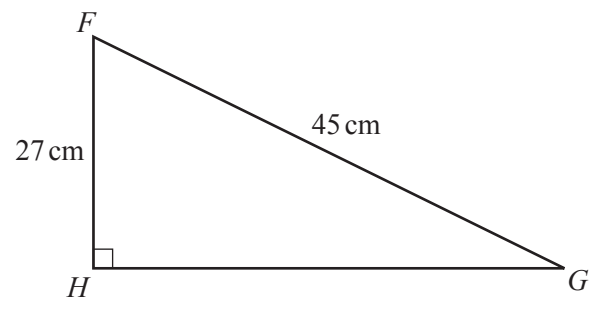

NOT TO SCALE

FGH is a right-angled triangle.

Calculate

(i) GH ,

Answer(c)(i) $GH = \dots\dots\dots\text{ cm}$ [3]

(ii) the perimeter of the triangle,

Answer(c)(ii) $\dots\dots\dots\text{ cm}$ [1]

(iii) the area of the triangle,

Answer(c)(iii) $\dots\dots\dots\text{ cm}^2$ [2]

(iv) angle FGH .

Answer(c)(iv) Angle $FGH = \dots\dots\dots$ [2]

8 (a) (i) Complete the table of values for $f(x) = -x^2 + 5x$.

x	-1	0	1	2	3	4	5	6
$f(x)$	-6		4			4	0	

[2]

(ii) On the grid, draw the graph of $y = f(x)$ for $-1 \leq x \leq 6$.

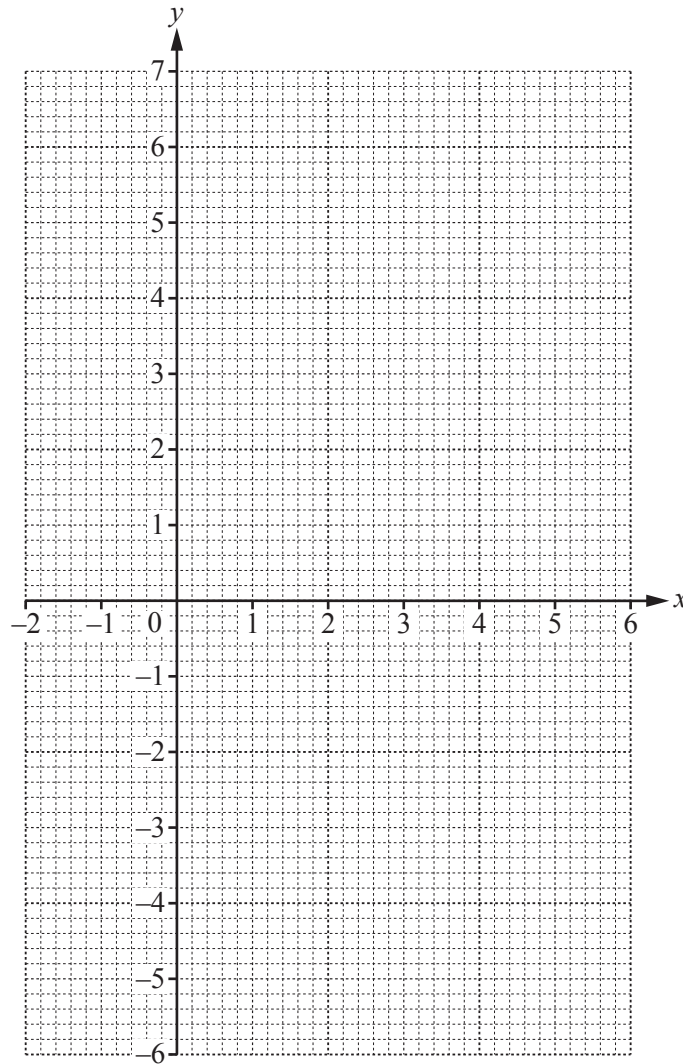

[4]

(b) Write down the co-ordinates of the highest point on the graph.

Answer(b) (.....,) [1]

(c) Use your graph to solve the equation $-x^2 + 5x = -3$.

Answer(c) $x = \dots\dots\dots$ or $x = \dots\dots\dots$ [2]

(d) (i) On the grid, draw the line of symmetry for the graph. [1]

(ii) Write down the equation of the line of symmetry for the graph.

Answer(d)(ii) $\dots\dots\dots$ [1]

(iii) The curve passes through the points $(-10, -150)$ and $(k, -150)$.

Use the symmetry of the curve to find the value of k .

Answer(d)(iii) $k = \dots\dots\dots$ [1]

Question 9 is printed on the next page.

9 All the children in a school are asked to choose their favorite color. The pie chart shows the results.

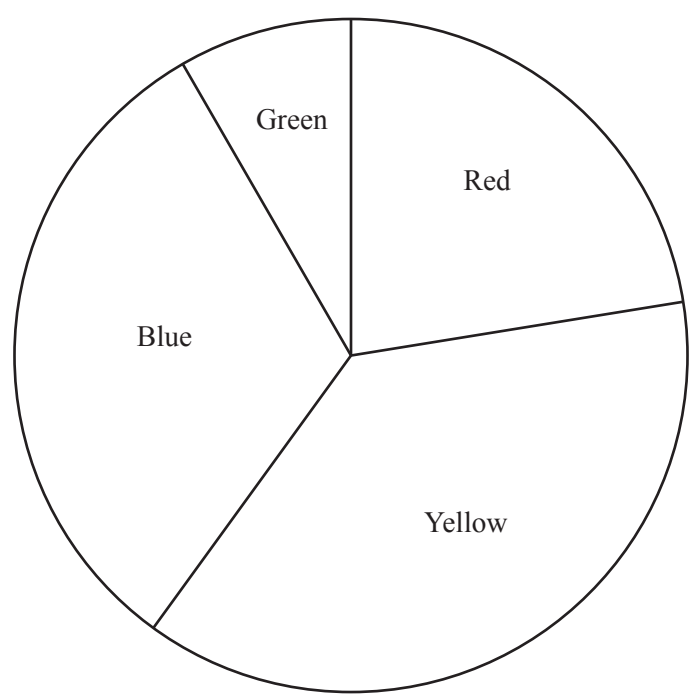

(a) Write down the least favorite color chosen.

Answer(a) [1]

(b) 27 children choose yellow as their favorite color.

Work out the total number of children in the school.

Answer(b) [3]

(c) Work out the percentage of the children in the school who choose red.

Answer(c) % [2]

Permission to reproduce items where third-party owned material protected by copyright is included has been sought and cleared where possible. Every reasonable effort has been made by the publisher (UCLES) to trace copyright holders, but if any items requiring clearance have unwittingly been included, the publisher will be pleased to make amends at the earliest possible opportunity.

To avoid the issue of disclosure of answer-related information to candidates, all copyright acknowledgements are reproduced online in the Cambridge International Examinations Copyright Acknowledgements Booklet. This is produced for each series of examinations and is freely available to download at www.cie.org.uk after the live examination series.

Cambridge International Examinations is part of the Cambridge Assessment Group. Cambridge Assessment is the brand name of University of Cambridge Local Examinations Syndicate (UCLES), which is itself a department of the University of Cambridge.