



Cambridge International Examinations
Cambridge International General Certificate of Secondary Education

PHYSICAL SCIENCE

0652/51

Paper 5 Practical Test

October/November 2018

CONFIDENTIAL INSTRUCTIONS

Great care should be taken to ensure that any confidential information given does not reach the candidates either directly or indirectly.

The Supervisor's attention is drawn to the form on page 8 which must be completed and returned with the scripts.

If you have any queries regarding these Confidential Instructions, please contact Cambridge, stating the Centre number, the nature of the query and the syllabus number quoted above.

email info@cie.org.uk
phone +44 1223 553554
fax +44 1223 553558



This document consists of **6** printed pages and **2** blank pages.

Instructions for preparing apparatus

These instructions detail the apparatus, reagents and specimens required by each candidate for each experiment in this paper. A summary of the questions that will be presented to the candidates is included, where appropriate, to allow the teacher to test the apparatus appropriately. **No access is permitted to the Question Paper in advance of the examination session.**

It is assumed that the ordinary apparatus of a science laboratory will be available, including a supply of purified water (distilled or deionised).

If arrangements are made for different sessions for different groups of candidates, care must be taken to ensure that the different groups of candidates are effectively isolated so that **no information passes between them.**

All specimens should carry only the code letters and numbers as indicated and their identity should not be revealed to the candidates.

Supervisors should ensure that all specimens have the correct identity attached to the specimen and that these are **not** removed during the examination.

If a candidate breaks any of the apparatus, or loses any of the material supplied, the matter should be rectified and a note made in the Supervisor's Report.

Supervisors are advised to remind candidates that **all** substances in the examination should be treated with caution. Only those tests described in the Question Paper should be attempted. Pipette fillers and suitable eye protection should be used where necessary.

In accordance with COSHH (Control of Substances Hazardous to Health) Regulations, operative in the UK, a hazard appraisal of the examination has been carried out.

The following codes are used where relevant.

C corrosive	MH moderate hazard
HH health hazard	T acutely toxic
F flammable	O oxidising
N hazardous to the aquatic environment	

The attention of Centres is drawn to any local regulations relating to safety, first aid and disposal of chemicals.

'Hazard Data Sheets', relating to materials used in this examination, should be available from your chemical supplier.

The Supervisor should make sure the Supervisor's Report is fully completed and a copy is enclosed with each packet of scripts.

Centres are reminded that they are **not** permitted to open the Question Paper envelopes before the examination. Centres are also referred to the Handbook for Centres, the Security of Question Papers and Examination Materials section, and the Practical Examinations in Science Subjects section.

If there are difficulties with any aspect of setting up this practical examination that the Centre is not able to resolve, it is essential for Centres to contact the Product Manager as soon as possible by email to info@cie.org.uk, by phone to +44 1223 553554 or by fax to +44 1223 553558.

For Question 1

Each candidate will require:

- [F N] (i) about 1 g of a homogeneous mixture of equal masses of powdered zinc, Zn, and solid zinc chloride, $ZnCl_2$, labelled **H**
- (ii) about 30 cm^3 distilled water
- [MH] (iii) about 40 cm^3 0.4 mol dm^{-3} sodium hydroxide solution, NaOH, labelled **sodium hydroxide**
- [MH] (iv) about 10 cm^3 0.1 mol dm^{-3} dilute nitric acid, HNO_3 , labelled **dilute nitric acid**
- (v) about 10 cm^3 0.1 mol dm^{-3} barium nitrate solution, $Ba(NO_3)_2$, labelled **barium nitrate**
- [N] (vi) about 10 cm^3 0.05 mol dm^{-3} silver nitrate solution, $AgNO_3$, labelled **silver nitrate**
- (vii) about 20 cm^3 2.0 mol dm^{-3} hydrochloric acid, HCl , labelled **dilute hydrochloric acid**
- (viii) 25 cm^3 measuring cylinder
- (ix) 100 cm^3 beaker
- (x) a stirring rod
- (xi) a filter funnel
- (xii) filter papers
- (xiii) 2 large test-tubes (approx. $150 \times 25\text{ mm}$)
- (xiv) 4 test-tubes (approx. $125 \times 15\text{ mm}$)
- (xv) a bung to fit test-tube in (xiv)
- (xvi) means to support test-tubes
- (xvii) 2 splints
- (xviii) Bunsen burner and means to light it.

Notes

- Centres may provide fewer test-tubes, the minimum being 1 large test-tube (approx. $150 \times 25\text{ mm}$) and 2 test-tubes (approx. $125\text{ mm} \times 15\text{ mm}$). If this is the case, candidates will have to rinse test-tubes with distilled water so more must be provided.
- Spare materials and equipment should be available and can be provided without penalty. Candidates should be made aware of this.

For Question 2

Each candidate will require:

- (i) a cell or power source of approximately 1.5V–2V. Where candidates are supplied with a power supply with a variable output voltage, the voltage should be set by the Supervisor and fixed (e.g. taped)
- (ii) 2 similar lamps of the same rating in suitable holders. Any low voltage lamps will be suitable, provided that they glow brightly when connected in parallel with the power supply. The voltage of the power supply should not exceed the rating of the bulbs.
- (iii) a switch
- (iv) an ammeter reading up to 1.0A with a minimum resolution of 0.05A
- (v) a voltmeter capable of measuring the supply p.d. with a minimum resolution of 0.1 V
- (vi) sufficient connecting leads to construct the circuit shown in Fig. 2.1
- (vii) 3 extra connecting leads for candidates to use when rearranging the given circuit.

Notes

1. The components are to be connected by the Supervisor, as shown in Fig. 2.1.

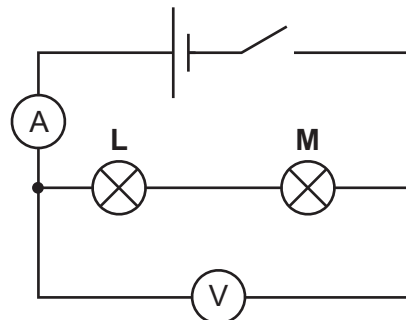

Fig. 2.1

2. Label the lamps **L** and **M**.
3. Candidates will be instructed to rearrange the circuit in Fig. 2.1.
4. Candidates will be required to rearrange and reconnect the given circuit unassisted. If help is required, it may be given, but the candidate number must be noted on the supervisor's report.

Action at changeover

Reconnect the circuit shown in Fig. 2.1.

Spare materials and equipment should be available and can be provided without penalty. **Candidates should be made aware of this.**

Information required from the Supervisor:

The Supervisor is asked to carry out the experiments and to enter the results on a spare copy of the examination paper, clearly marked 'Supervisor's Report' and showing the Centre number. This should be done out of sight of the candidates, using the same solutions, reagents, specimens and apparatus as the candidates.

A copy of the Supervisor's Report should be returned with each packet of scripts. Failure to do so may cause the candidates to be penalised.

This form must be completed and returned in the envelope with the scripts together with the seating plan and the Supervisor's Report as mentioned on page 6.

October/November 2018

General

The Supervisor is invited to give details of any difficulties experienced by particular candidates giving their names and candidate numbers. These should include reference to:

- (a) difficulties due to faulty apparatus;
- (b) accidents to apparatus or materials;
- (c) physical handicaps, e.g. short sight, colour blindness;
- (d) any other information that is likely to assist the Examiner, especially if this cannot be discovered in the scripts;
- (e) any help given to a candidate.

The Supervisor is asked to supply the following information:

Plan of work benches, giving details by candidate numbers of the places occupied by the candidates for each session and a copy of the Supervisor's Report.

NAME OF CENTRE

CENTRE NUMBER

DECLARATION (to be signed by the Supervisor)

The preparation of this practical examination has been carried out so as to maintain fully the security of the examination.

NAME
(in block capitals)

SIGNED (Supervisor)

Permission to reproduce items where third-party owned material protected by copyright is included has been sought and cleared where possible. Every reasonable effort has been made by the publisher (UCLES) to trace copyright holders, but if any items requiring clearance have unwittingly been included, the publisher will be pleased to make amends at the earliest possible opportunity.

To avoid the issue of disclosure of answer-related information to candidates, all copyright acknowledgements are reproduced online in the Cambridge International Examinations Copyright Acknowledgements Booklet. This is produced for each series of examinations and is freely available to download at www.cie.org.uk after the live examination series.

Cambridge International Examinations is part of the Cambridge Assessment Group. Cambridge Assessment is the brand name of University of Cambridge Local Examinations Syndicate (UCLES), which is itself a department of the University of Cambridge.